



strautmänn

Operating instructions

Fodder mixing wagon

Verti-Mix 3451 Triple

Verti-Mix 4501 Triple

W09671000_OS38001 - W09672999_OS38999

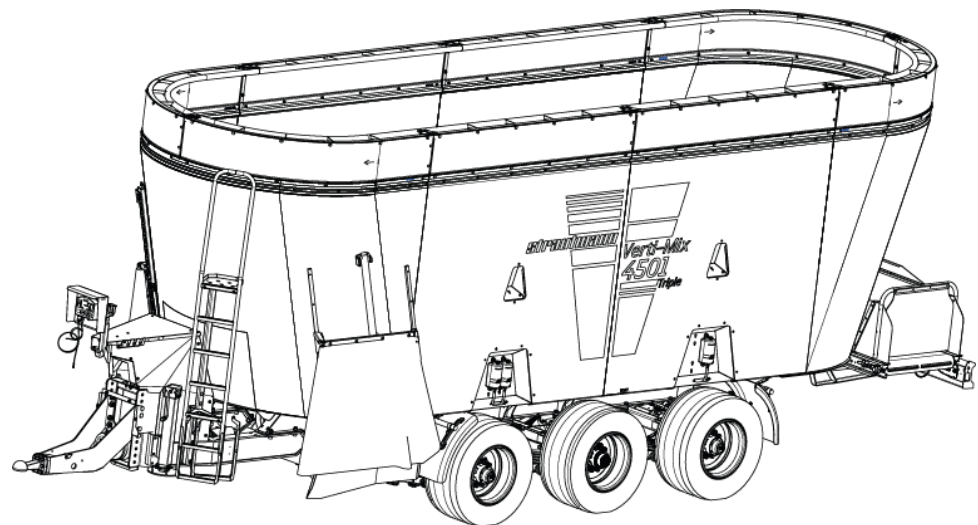

Original instructions

671009001

0.000 | 01.19



EU Declaration of Conformity

Manufacturer:

B. Strautmann & Söhne GmbH u. Co. KG
Bielefelder Str. 53 | D-49196 Bad Laer

Legal person established within the Union and authorised to compile the technical documentation:

B. Strautmann & Söhne GmbH u. Co. KG
Bielefelder Str. 53 | D-49196 Bad Laer

Description and identification of machine:

Designation: Fodder mixing wagon
Function: Chopping, mixing, transport and discharge of all types of silage and normal fodders used in keeping livestock
Model: Verti-Mix Triple
Type: Verti-Mix 3451 Triple
Verti-Mix 4501 Triple
Vehicle/Machine ID number: W09671000_0S38001 - W09672999_0S38999
Trade name: Fodder mixing wagon Verti-Mix Triple

We hereby explicitly declare that the machine complies with all relevant provisions of the following directives:

2006/42/EC:2006-05-17 EC machinery directive 2006/42/EC
2014/30/EU:2014-02-26 Electromagnetic compatibility directive 2014/30/EU

Sources of the applied harmonised standards according to article 7 paragraph 2:

EN ISO 12100:2011 Safety of machinery - Basic concepts, general principles for design - Risk assessment and risk reduction
EN ISO 13857:2008 Safety of machinery - Safety distances to prevent hazard areas from being reached by upper and lower limbs
EN ISO 4254-1:2016-09 Agricultural machinery - Safety - Part 1: General requirements
EN 349:1993+A1:2008 Safety of machinery - Minimum distances to prevent limbs from being crushed
EN ISO 4413:2011-04 Fluid power - General rules and safety requirements for hydraulic systems and their components
EN 703:2004+A1:2009 Agricultural machinery - Machines for loading, mixing and/or chopping and distributing silage

Bad Laer, 02.04.2019

Dipl.-Kfm. W. Strautmann
Managing Director

| Manufacturer | |
|---------------------|---|
| Address | B. Strautmann & Söhne GmbH u. Co. KG Bielefelder Straße 53 D-49196 Bad Laer |
| Phone | + 49 (0) 5424 802-0 |
| Fax | + 49 (0) 5424 802-64 |
| E-mail | info@strautmann.com |
| Internet | http://www.strautmann.de |

| Customer service | |
|-------------------------|----------------------|
| Phone | + 49 (0) 5424 802-30 |
| Fax | + 49 (0) 5424 802-64 |
| E-mail | parts@strautmann.com |

| Identification data | |
|--|--|
| They are registered on the type plate. Please enter the data of your machine here: | |
| ID no. | |
| Model | |
| Year of manufacture | |

Copyright

All copyrights and property rights to this machine and all related technical documentation remain with B. Strautmann & Söhne GmbH u. Co. KG.

The contents of these instructions are protected by copyright. The use is admissible within the exploitation of the machine. The instructions must not be reproduced, distributed or modified without the written consent of the manufacturer.

All rights reserved.

© Copyright | B. Strautmann & Söhne GmbH u. Co. KG

Table of contents

| | | |
|--------|---|----|
| 1 | About these instructions | 10 |
| 1.1 | Target group | 11 |
| 1.2 | Other relevant documents | 11 |
| 1.3 | Representational conventions | 12 |
| 1.3.1 | Activities and lists | 12 |
| 1.3.2 | References and further information | 13 |
| 1.3.3 | Location details | 13 |
| 1.3.4 | Warning signs | 14 |
| 1.4 | Applied terms | 16 |
| 1.5 | Abbreviations | 16 |
| 2 | Safety | 17 |
| 2.1 | General information on safety | 17 |
| 2.2 | Correct use | 17 |
| 2.3 | Reasonably foreseeable misuse | 18 |
| 2.4 | Safety-conscious working | 19 |
| 2.5 | Technical alterations | 19 |
| 2.6 | User's obligation | 20 |
| 2.7 | Operator's obligation | 20 |
| 2.7.1 | Staff requirements | 21 |
| 2.7.2 | Personal protective equipment (PSA) | 23 |
| 2.8 | Risk potential and residual risks | 23 |
| 2.8.1 | Hazardous area and dangerous spots | 24 |
| 2.8.2 | Risks due to moving parts | 25 |
| 2.8.3 | Risks due to hydraulic and pneumatic energy | 26 |
| 2.8.4 | Risks due to electrical energy | 27 |
| 2.8.5 | Risks due to hot spots | 28 |
| 2.8.6 | Risks when handling chemical substances | 28 |
| 2.9 | Brake system | 29 |
| 2.10 | Axles | 30 |
| 2.11 | Environmental protection | 30 |
| 2.12 | Warranty and liability | 31 |
| 2.13 | Safety and protective devices | 32 |
| 2.14 | Signs at the machine | 35 |
| 2.14.1 | Warning signs | 35 |
| 2.14.2 | Instruction signs | 41 |
| 2.14.3 | Placing of warning and instruction signs | 42 |
| 3 | Technical data | 45 |
| 3.1 | General data | 45 |
| 3.2 | Dimensions of wagon | 46 |
| 4 | Description of machine | 48 |
| 4.1 | General overview | 49 |
| 4.2 | Chassis | 51 |
| 4.2.1 | Chassis with mechanical suspension | 51 |
| 4.3 | Steering axle | 51 |
| 4.3.1 | Passive steering axle | 51 |
| 4.3.2 | Forced steering axle system | 52 |

| | | |
|--------|--|----|
| 4.4 | Hydraulic system | 53 |
| 4.5 | Connections | 53 |
| 4.6 | Drawbar | 54 |
| 4.7 | Brake system..... | 55 |
| 4.7.1 | Hydraulic working brake..... | 55 |
| 4.7.2 | Hydraulic service brake..... | 56 |
| 4.7.3 | Compressed-air brake system | 57 |
| 4.7.4 | Parking brake | 58 |
| 4.8 | Mixing container and mixing augers | 59 |
| 4.8.1 | Feed funnel for mineral feed | 59 |
| 4.8.2 | Magnetic system | 60 |
| 4.9 | Discharge options | 61 |
| 4.10 | Traffic-related equipment | 63 |
| 4.11 | Type plate..... | 64 |
| 5 | Transport | 65 |
| 5.1 | Safety | 65 |
| 5.2 | Lashing and anchorage points | 66 |
| 6 | Commissioning..... | 67 |
| 6.1 | Safety | 67 |
| 6.1.1 | Road traffic regulations | 67 |
| 6.2 | Tractor's compatibility..... | 68 |
| 6.3 | Required tractor equipment..... | 69 |
| 6.4 | Combination options of coupling devices and drawgears..... | 71 |
| 6.5 | D _c value and towing capacity | 72 |
| 6.5.1 | Calculate D _c value | 73 |
| 6.5.2 | Calculate towing capacity | 74 |
| 6.6 | Hitch and unhitch machine..... | 75 |
| 6.6.1 | Safety | 75 |
| 6.6.2 | Hitch machine | 76 |
| 6.6.3 | Unhitch machine | 77 |
| 6.7 | Forced steering axle system | 78 |
| 6.7.1 | Safety | 78 |
| 6.7.2 | Couple forced steering axle | 79 |
| 6.7.3 | Uncouple forced steering axle | 82 |
| 6.8 | Drawbar | 83 |
| 6.8.1 | Adapt mounting height of drawbar | 83 |
| 6.8.2 | Couple drawbar..... | 85 |
| 6.8.3 | Uncouple drawbar | 88 |
| 6.9 | Propeller shaft | 90 |
| 6.9.1 | Safety | 90 |
| 6.9.2 | Adapt length of propeller shaft | 91 |
| 6.9.3 | Couple propeller shaft to tractor..... | 93 |
| 6.9.4 | Uncouple propeller shaft from tractor..... | 94 |
| 6.10 | Supporting leg | 95 |
| 6.10.1 | Mechanical supporting leg | 95 |
| 6.10.2 | Hydraulic supporting leg | 97 |
| 6.10.3 | Fixed supporting leg with bottom hitch..... | 98 |

| | | |
|--------|---|-----|
| 6.11 | Check machine for proper functioning | 99 |
| 6.12 | Hydraulic hose pipes | 100 |
| 6.12.1 | Safety | 100 |
| 6.12.2 | Hydraulikschlauchleitungen ankuppeln..... | 101 |
| 6.12.3 | Hydraulikschlauchleitungen abkuppeln..... | 101 |
| 6.13 | Brake system..... | 102 |
| 6.13.1 | Hydraulic working brake..... | 102 |
| 6.13.2 | Compressed-air brake system | 104 |
| 6.13.3 | Hydraulic service brake..... | 108 |
| 6.13.4 | Parking brake | 108 |
| 6.14 | Container extension | 110 |
| 6.14.1 | Safety | 110 |
| 6.15 | Set conveyor speed | 111 |
| 6.15.1 | Manually set conveyor speed | 111 |
| 6.15.2 | Set conveyor speed via control set | 111 |
| 6.15.3 | Set control dial range of E-control set..... | 112 |
| 6.16 | Mount control set on the tractor | 114 |
| 6.16.1 | Mount holder for Bowden cable control set | 114 |
| 6.16.2 | Mount E-control set..... | 114 |
| 6.17 | Battery for weighing device | 115 |
| 6.18 | Set deflector plate | 117 |
| 6.18.1 | Mechanical deflector plate | 117 |
| 7 | Operation..... | 118 |
| 7.1 | Tractor direct connection..... | 118 |
| 7.2 | Bowden cable control set..... | 119 |
| 7.2.1 | Symbols on the control set..... | 120 |
| 7.3 | E-control set | 123 |
| 7.3.1 | Symbols on the control set..... | 124 |
| 7.4 | Information display for power shift gearbox | 129 |
| 7.4.1 | Display information..... | 129 |
| 7.4.2 | Navigation layout of displays | 130 |
| 7.4.3 | Displays..... | 130 |
| 8 | Operation..... | 132 |
| 8.1 | Safety | 132 |
| 8.2 | Fill machine | 134 |
| 8.2.1 | Filling procedure..... | 136 |
| 8.2.2 | Filling order | 137 |
| 8.3 | Mix fodder components..... | 138 |
| 8.3.1 | Mount counter-cutters | 139 |
| 8.4 | Discharge fodder..... | 140 |
| 8.4.1 | Discharge procedure..... | 141 |
| 8.4.2 | Eliminate blockages | 142 |
| 8.5 | Working with the fast bedding roller..... | 143 |
| 8.5.1 | Start bedding..... | 144 |
| 8.5.2 | Finish bedding..... | 144 |
| 8.6 | Change gear level by means of switchgear | 145 |
| 8.6.1 | Change gear level with small amount of load | 146 |

| | | |
|---------|---|-----|
| 8.6.2 | Change gear level with large amount of load | 146 |
| 8.7 | Change gear level at power shift gearbox | 147 |
| 8.8 | Emergency draining by means of power shift gearbox..... | 149 |
| 8.9 | Transport journeys | 150 |
| 8.10 | Secure protective devices | 152 |
| 8.11 | Secure discharge conveyor or conveyor extension | 153 |
| 8.12 | Safely park tractor and machine | 154 |
| 9 | Malfunctions | 155 |
| 9.1 | Safety | 155 |
| 9.1.1 | List of malfunctions, machine..... | 156 |
| 9.1.2 | List of malfunctions, electrical system..... | 157 |
| 9.1.3 | List of malfunctions, weighing device..... | 158 |
| 9.2 | Emergency manual operation | 159 |
| 10 | Service and maintenance..... | 161 |
| 10.1 | Safety | 161 |
| 10.2 | Maintenance instructions | 163 |
| 10.3 | Lubricants and operating media..... | 163 |
| 10.4 | Tightening torques | 164 |
| 10.4.1 | Metric standard threads | 165 |
| 10.4.2 | Wheel nuts | 166 |
| 10.5 | Maintenance and lubrication plan | 167 |
| 10.5.1 | Maintenance plan – Machine | 168 |
| 10.5.2 | Maintenance plan – Chassis..... | 171 |
| 10.5.3 | Lubrication plan – Machine | 174 |
| 10.5.4 | Lubrication plan – Chassis..... | 175 |
| 10.6 | Enter the mixing container | 177 |
| 10.7 | Clean machine | 179 |
| 10.8 | Clean oil cooler | 180 |
| 10.9 | Lubricate machine..... | 180 |
| 10.10 | Gear lubricant oil..... | 181 |
| 10.10.1 | Mixer gearbox | 182 |
| 10.10.2 | Switchgear | 184 |
| 10.10.3 | Power shift gearbox (2-gear) | 185 |
| 10.10.4 | Power shift gearbox (3-gear) | 188 |
| 10.11 | Replace shear bolts of shear bolt coupling | 191 |
| 10.12 | Dosage gate – Check gap size | 192 |
| 10.13 | Mixing auger – Cutting knives | 193 |
| 10.13.1 | Check cutting knives | 193 |
| 10.13.2 | Replace cutting knives | 194 |
| 10.14 | Mixing auger – Magnetic system..... | 199 |
| 10.15 | Crossover conveyor, discharge conveyor, conveyor extension..... | 200 |
| 10.15.1 | Check and visually check tension of conveyor belt | 200 |
| 10.15.2 | Tighten and adjust conveyor belt..... | 201 |
| 10.15.3 | Clean driving rollers, carrying rollers and pulleys | 201 |
| 10.16 | Mechanical Bowden cable operation | 202 |
| 10.16.1 | Replace Bowden cable | 202 |
| 10.16.2 | Remote control cable – Replace adapter | 203 |

| | | |
|---------|--|-----|
| 10.17 | Hydraulic system | 204 |
| 10.17.1 | Safety | 204 |
| 10.17.2 | Maintenance intervals | 205 |
| 10.17.3 | Depressurise hydraulic system | 206 |
| 10.17.4 | Hydraulic hose pipes | 207 |
| 10.17.5 | Set hydraulic oil pressure of forced steering axle system..... | 209 |
| 10.18 | Tyres | 210 |
| 10.18.1 | Safety | 210 |
| 10.18.2 | Check tyres | 211 |
| 10.18.3 | Change tyres | 212 |
| 10.19 | Compressed-air brake system | 213 |
| 10.19.1 | Drain compressed-air reservoir..... | 213 |
| 10.19.2 | Check and clean in-line filters | 214 |
| 10.19.3 | Check brake system for proper functioning. | 215 |
| 10.19.4 | Set compressed-air brake system | 215 |
| 10.19.5 | Set hydraulic brake system..... | 216 |
| 10.20 | Check brake linings..... | 216 |
| 10.21 | Lubricate brake shaft bearing..... | 217 |
| 10.22 | Lubricate manual slack adjuster..... | 217 |
| 10.23 | Lubricate knuckle arm bearing | 218 |
| 10.24 | Check play of wheel hub bearing | 218 |
| 11 | Spare parts | 219 |
| 13 | Index..... | 220 |

1 About these instructions

Dear customer,

You have decided in favour of a quality product from the large B. Strautmann & Söhne GmbH u. Co. KG product range. We thank you for the confidence you have shown in us.

Upon receipt of the machine, please check for transport damage or missing parts. Inspect the delivered machine for completeness, including the ordered optional extras, by means of the delivery note.

Only immediate complaints will give reason to compensation!

Read and observe these operating instructions and any other enclosed operating instructions for individual machine components before the first start-up; in case of doubt, the details and information in such sub-supplier documentation shall prevail!

These instructions contain descriptions and important information for the safe and efficient use of the machine. They are part of the machine. Therefore, always keep these operating instructions in the machine. Hand these operating instructions over to the buyer when the machine is sold.

The staff shall have carefully read and understood these instructions before starting work.

The machines are available with various optional extras. Due to the individual equipment of your machine, not all descriptions included in these operating instructions apply to your machine. Optional extras are marked in these operating instructions and are available at extra cost.

In case of any inquiries or problems, please refer to these operating instructions or call us.

Regular service and maintenance and timely replacement of worn-out or damaged parts will result in a longer service life of your machine.

1.1 Target group

These operating instructions are primarily intended for the operator of the machine.

Operator

The operator has been instructed in working with the machine and informed about possible risks in case of improper behaviour. The operator has reached the minimum age of 18 years.

Qualified staff

The members of staff have completed the respective professional training qualifying them to carry out maintenance and troubleshooting work.

A workshop manual is delivered separately.

Minimum qualifications and staff requirements, ► see section 2.7.1, page 21.

1.2 Other relevant documents

In addition to these instructions, further documents shall apply, such as e.g. documentation of sub-suppliers and circuit diagrams. Observe and always adhere to the specifications and instructions contained therein.

1.3 Representational conventions

To facilitate easy and fast comprehension, different information in these instructions is represented or highlighted as follows:

1.3.1 Activities and lists

Activities which have to be carried out in a predetermined order are specified as numbered instructions. In some cases, the response of the machine to the respective instruction is marked by an arrow.

Instructions

1. First step
 2. Second step
 3. ...
- Response of machine
- Adhere to the order of the steps.

Lists without predetermined order

Introductory phrase

- Information
- Information
- ...

Subordinate lists

- Subitem
- Subitem
- ...

Position numbers in figures, legends, continuous text

- 1 Machine part
- 2 Machine part
- 3 ...

Position numbers in a continuous text are indicated in parentheses (1).

Lines of position in figures

Starting from the position numbers, the lines of position refer to the respective components.

————— A line without an arrow means that the machine part can be seen in the figure.

—————→ A line with an arrow means that the machine part is hidden in the figure and is therefore not visible.

1.3.2 References and further information

References

A preceding arrow head ► indicates a reference to further information elsewhere in the operating instructions.

Example:

- Please refer to paragraph 9.10, page 21.

Notes and additional information

NOTE

Notes are highlighted as shown here.

- Notes contain additional information, recommendations and tips.
 - Notes do not contain any warnings of risks.
-

Environmental protection



This symbol marks information about environmental protection.

1.3.3 Location details

Any directional data in these operating instructions refer to the direction of motion.

1.3.4 Warning signs

Signal words

Warning information is highlighted by a signal word. The signal word explains the extent of a risk. The signal words DANGER, WARNING and CAUTION mark risks to people.

Risks to people are additionally marked by the general hazard symbol . It is imperative to observe these warning signs to avoid injuries or death.

The signal word *ATTENTION* marks risks of material damage. The information regarding material damage is not preceded by a symbol.

Risk levels

DANGER

Marks a dangerous situation which will cause serious injuries or even death if it is not prevented.

WARNING

Marks a dangerous situation which may cause serious injuries or even death if it is not prevented.

CAUTION

Marks a dangerous situation which may cause injuries if it is not prevented.

ATTENTION

Marks measures to avoid material damage.

Paragraph-related warning information

Paragraph-related warning information refers to entire chapters, a paragraph or several paragraphs in these instructions.

Paragraph-related warning information is structured according to the following layout:

**SIGNAL
WORD**

Kind and source of risk

Possible consequences in case of non-observance of risk

- Measures to avoid a dangerous situation.
-

Embedded warning information

Embedded warning information is situation-related and refers to a certain activity or to a part within a paragraph.

Embedded warning information is structured according to the following layout:

⚠ SIGNAL WORD – Kind of risk. Measures to avoid a dangerous situation.

1.4 Applied terms

| Term | Description |
|--------------------|---|
| Third person/party | All other persons apart from the operator. |
| Risk | The source of a possible injury or damage to health. |
| Manufacturer | B. Strautmann & Söhne GmbH u. Co. KG |
| Machine | Fodder mixing wagon Verti-Mix |
| Operating element | Part of an operating device which is directly actuated by the operator, e.g. by pressing. An operating element may be an adjusting lever, a key button, rotary switch, key etc. |

Tab. 1: Terms

1.5 Abbreviations

| Abbreviation | Description |
|---|--------------------------------|
| StVZO (note of transl.: German Road Traffic Licensing Code) | Road Traffic Licensing Code |
| SES | Strautmann Electronic Steering |

Tab. 2: Abbreviations

2 Safety

2.1 General information on safety

The chapter Safety contains basic safety instructions and provides an overview of all important safety aspects. Further task-related safety instructions are included in the paragraphs about the individual phases during the life cycle. Adherence protects your own safety.

2.2 Correct use

The fodder mixing wagons of the Verti-Mix series are designed for chopping, homogeneous mixing, transport and discharge all types of silage and normal fodders used in keeping livestock if the dry substance content of the total mixture is more than 30 % at any time of the mixing process, The fodder mixing wagons are only allowed to be filled by means of the following vehicles and equipment:

- Tractor with front loader
- Yard or wheeled loader
- Telescopic loader
- Provided feeding aids such as e.g. mineral feed funnel
- Directly from the pipe or conveying device for concentrated feed, mineral feed etc.

The machine is only allowed to be operated by **one** person.

The following is also part of the correct use:

- The observance of all instructions contained herein,
- the observance of the specified service and maintenance work on the machine,
- the exclusive use of original spare parts.

Any use beyond the above is prohibited and will be regarded as incorrect.

The user will be solely responsible for any damage resulting from incorrect use; the manufacturer will not assume any liability.

2.3 Reasonably foreseeable misuse

The following points describe a reasonably foreseeable misuse of the machine:

- Participation in road traffic with overloaded machine
- Dropping of large fodder quantities into the mixing container from an excessive height
- Removal of stuck fodder from the charging tools at the container (container top edge or overflow ring)
- Long interruption of the mixing process with the mixing container heavily filled
Long interruptions cause large "breakaway torques" and thus a strong load exerted on the power train.
- Large angular misalignment of the propeller shaft due to alignment of the tractor in relation to the fodder mixing wagon during mixing mode
- Dosage of the fodder quantity to be discharged by means of the conveyor speed with the discharge gate completely open
- Entry into the mixing container via the ladder and over the top edge of the container
- Use the hydraulic protective box as a platform
- Replacement of shear bolts on propeller shafts by bolts of greater shear force

2.4 Safety-conscious working

Observe as the basic prerequisite for safe working:

- All specified safety and warning information as well as the instructions in these operating instructions
- Instructions regarding correct use
- Warning signs on the machine
- General national occupational safety, accident prevention and environmental protection rules
- National road traffic regulations for transport journeys
- Operation of the machine only in a sound safety-related condition
- Wearing of personal protective equipment
- Make sure that third parties and animals leave the hazardous area before operating the machine. Particularly be aware of children.
- Never carry passengers, animals or objects on the machine.

2.5 Technical alterations

You are only allowed to carry out technical alterations, extensions or modifications on the machine with the prior written consent of the manufacturer.

The manufacturer will not assume any liability for damage resulting from:

- Unauthorised alterations of the machine
- Use of non-approved parts
- Welding and drilling work on load-bearing parts of the machine

In case of non-observance, the declaration of conformity and the CE symbol of the machine will become invalid. Furthermore, the operating license according to national and international regulations will become invalid.

2.6 User's obligation

The user himself is responsible for observance of the binding laws, rules, applicable local provisions and national regulations.

The user is obliged

- to exclusively have staff working with and on the machine who have been instructed how to operate the machine and possess the minimum qualification.
- to provide the necessary personal protective equipment.
- to keep all warning signs attached to the machine in legible condition. Immediately replace missing or damaged warning signs.

2.7 Operator's obligation

Any people charged to work with and on the machine are obliged

- to acquaint themselves with the machine before starting work.
- to observe the general national occupational safety, accident prevention and environmental protection rules.
- to adhere to the instructions in these operating instructions.

2.7.1 Staff requirements

The different tasks described in these operating instructions place different requirements on the qualification of the people entrusted with such tasks.

Inexperienced and insufficiently qualified members of staff are not able to evaluate the risks associated with the handling of the machine, thus endangering themselves and other people.

- Only trained and instructed members of staff, who have been informed about the risks, are allowed to carry out the work.
- Members of staff to be trained must be supervised by experienced qualified staff members when working on the machine.
- Only people expected to reliably carry out the work, are allowed to carry out such work.
- Only authorised workshops are allowed to carry out work requiring special expert knowledge.

Unless otherwise provided by law, the admissible members of staff, their minimum qualification and their deployment after the machine's life cycle are specified. See the following table:

| Staff | Activity | Qualification | Life cycle |
|---|--|--|--|
| Qualified staff for load transport | Transport and loading/unloading | Proven experience in handling suspended loads and securing loads ¹⁾ | Transport, loading |
| Qualified staff (mechanics, hydraulics, pneumatics) | Work on mechanical, hydraulic and pneumatic components | Vocational training as an agricultural mechatronic technician or an equal professional qualification (internal training course and/or external training) ¹⁾ | Commissioning, troubleshooting, maintenance |
| Qualified electricians | Electro-technical work | Professional training in electrical engineering or an equal professional qualification (internal training course and/or external training) ¹⁾ | Commissioning, troubleshooting, maintenance |
| Operator | Operation and use of machine | Person instructed by the user based on the operating instructions | Commissioning, operation, handling, troubleshooting, maintenance |
| Qualified staff (disposer) | Professional disposal | Knowledge of the disposal regulations applicable at the place of operation | Disassembly, disposal |



Tab. 3: Qualifications of staff

1) Minimum professional experience of 3 years

2.7.2 Personal protective equipment (PSA)

Various work activities on the machine require personal protective equipment. Wearing the personal protective equipment protects your safety.

- Wear the required personal protective equipment when carrying out work on the machine.

| | |
|--|---|
|  | <p>Wear safety footwear Safety footwear provides a good anti-slip effect and protects the feet against falling objects.</p> |
|  | <p>Wear protective gloves Protective gloves protect the hands against slight crushing, cuts, infections and hot surfaces.</p> |
|  | <p>Wear protective clothing Close-fitting clothing protects people against becoming entangled by moving machine parts. Furthermore, the protective clothing protects the skin against slight mechanical effects.</p> |
|  | <p>Wear protective goggles Protective goggles protect the eyes against flying particles and operating media squirting out.</p> |

2.8 Risk potential and residual risks

Basic risks of the machine are indicated here.

The residual risks are determined by means of a risk evaluation. Any people working on the machine, must

- be aware of such residual risks.
- have been internally instructed, taking into account the professional qualification.
- adhere to instructions to minimise residual risks and avoid accidents or damage.

2.8.1 Hazardous area and dangerous spots

The hazardous area is the area within and/or in the vicinity of a machine, in which the safety or health of people might be impaired.

People are not allowed in the hazardous area

- if the tractor engine is running with the propeller shaft coupled / the hydraulic/electronic system connected.
- if tractor and machine are not secured against accidental starting and rolling.

Only when there are no people within the hazardous area of the machine, is the operator allowed to

- move the machine.
- set movable machine parts from transport to working position and from working to transport position.
- power working tools.

The machine is only allowed to be operated from the driver seat of the tractor when there are no people within the machine's hazardous area.

Risks may arise due to the following situations:

- Work-related movements of the machine and its working tools
- Substances or foreign objects flung out of the machine
- Accidental lowering of the lifted machine/of lifted machine parts
- Accidental starting and rolling of the machine/of tractor and machine

Dangerous spots

- within the drawbar area between tractor and machine
- within the area of the powered propeller shaft
- within the area of the discharge openings
- within the area of the powered discharge conveyor, crossover conveyor or extension conveyor
- in the mixing container with the machine powered or not powered
- around the discharge pipe and in ejection direction in case of machines equipped with straw blower

2.8.2 Risks due to moving parts

Easily accessible moving parts may cause serious injuries or even death. Risk of being trapped, drawn in or caught by moving parts.

- Keep a safety distance from the moving parts.
- Never open covers during operation.
- Wait for the machine to stop completely before carrying out maintenance and repair work.
- Observe the follow-up time. Make sure that machine parts are no longer moving before opening covers.
- Wear close-fitting clothing.
- Do not wear any rings, necklaces, bracelets or other jewellery.
- If you have long hair, wear a hairnet.
- Secure tractor and machine against starting and rolling, in order to prevent unintentional machine movements.

Pay particular attention during propeller shaft operation to the following:

- The operating instructions for the propeller shaft. Specifications in the sub-supplier documentation shall prevail.
- A protective device in proper condition must each be mounted at the p.t.o. shaft of the tractor and of the machine.
- Mounting and dismounting of the propeller shaft is only allowed
 - with the p.t.o. shaft switched off.
 - with the tractor engine turned off.
 - with the ignition key pulled out.
 - with the parking brake applied.
- Never switch the propeller shaft on with the tractor engine turned off.
- Slip the protective element onto the p.t.o. shaft stub after removal of the propeller shaft.

2.8.3 Risks due to hydraulic and pneumatic energy

Hydraulic and pneumatic components under pressure may perform uncontrolled movements in case of improper handling. Furthermore, medium may squirt out under high pressure from pressurised components in case of a malfunction. Risk of serious injuries or even death.

- Only an authorised workshop is allowed to carry out work on hydraulic and pneumatic components.
- Before carrying out any work,
 - depressurise; discharge residual energies.
 - make sure to prevent accidental outflow of the medium.
 - secure lifted movable machine parts against accidental lowering.
 - turn the engine off. Pull the ignition key out.
 - apply the parking brake.
- Have all hose pipes checked for their operational safety by an expert at least once a year.
- Regularly check all pipes, hoses and screwed connections for leakage and visible damage. Eliminate damage immediately.
- Never try to plug hose pipe leaks with your hands or fingers. Media squirting out under high pressure may penetrate the skin and enter the body, potentially causing serious injuries.
- Never detect leakages with your bare hands. Immediately contact an authorised workshop if a leak is suspected.
- Immediately contact the medical services if injuries caused by hydraulic oil occur. Risk of serious infection.
- Risk of explosion due to improper work on hydraulic accumulators.
 - Welding, soldering, drilling or other work which might affect the mechanical properties is not allowed.

2.8.4 Risks due to electrical energy

Danger to life due to electric current when coming into contact with conductive parts. Risk of serious injuries or even death. Furthermore, switched-on electrical machine parts may perform uncontrolled movements.

- Do not reach into conductive areas.
- Have work on electrical systems and operating media carried out by qualified electricians only and in accordance with electro-technical regulations.
- Before carrying out any work on the electrical system, disconnect the minus pole of the battery.
- Always cover the plus pole of the battery as required. Risk of explosion in case of accidental ground.
- Only use the specified fuses. If the rating of the fuses used is too big, the electrical system may be destroyed. Risk of fire.
- Ensure correct order when connecting and disconnecting the battery.
 - Connection: First connect the plus pole, then the minus pole.
 - Disconnection: First disconnect the minus pole, then the plus pole.
- Avoid sparking and open fire in the vicinity of the battery. Risk of explosion.
- Regularly check the electrical equipment for damage. Risk due to loose cable connections and scorched cables. Remedy defects immediately.
- Keep humidity away from conductive parts. Risk of a short circuit.
- The machine can be equipped with electronic components, the functioning of which may be affected by electromagnetic emissions of other devices. Such interferences may be a risk to people if the following safety instructions are not observed:
 - In case of a retrofitting of electronic components into the machine and their connection to the on-board electrical system, the staff authorised by the user must check on their own responsibility whether the retrofitted parts interfere with the vehicle electronics or other components.
 - Retrofitted electronic components must comply with the EMC directive as amended from time to time and bear the CE symbol.
- Never fit the machine with additional work lights without authorisation.

2.8.5 Risks due to hot spots

Risk of burns due to high surface temperature at the drive motor and machine components.

- Keep a safety distance from hot components.

When carrying out work on or in the vicinity of hot spots of the machine,

- wear protective clothing.
- switch off machine parts if necessary.
- allow machine parts to cool down.

2.8.6 Risks when handling chemical substances

Contact with oils, greases and other auxiliary materials may provoke chemical reactions. Risk of scalding when handling hot operating media and auxiliary materials.

- Observe and adhere to the applicable regulations and safety data sheets of the manufacturers when handling chemical substances.
- In case of contact with the eyes or skin, rinse the affected spot immediately with plenty of water.

2.9 Brake system

Observe the following points:

- The brake system of the tractor must be compatible with the brake system of the machine.
- Immediately stop the tractor in case of a malfunction. Have the malfunction promptly remedied by an authorised workshop.
- Only authorised workshops or recognised brake services are allowed to carry out adjustment and repair work on the brake system.
- Have the brake system checked by an authorised workshop every 200 service hours.
- In order to maintain the operational safety, the wheel brakes must always be properly adjusted.
- Before carrying out any work on the brake system
 - safely park the machine and secure it against accidental rolling.
 - secure the lifted machine/machine parts against accidental lowering.
- Especially beware when carrying out welding and drilling work and work involving open fire in the vicinity of brake lines.
- Always test the brakes after completion of work on the brake system.

Additionally observe the following points for compressed-air brake systems:

- Clean the sealing rings at the hose couplings of the feed and brake lines from soiling before hitching the machine.
- Only start the tractor with the hitched machine moving when the pressure gauge on the tractor indicates 5.0 bar.
- Drain the air reservoir every day.
- Cover the tractor's hose couplings before carrying out journeys without machine.
- Hang the couplings of the feed and brake line onto the provided blank connections with the machine unhitched.
- Do not modify the specified settings at the brake valves.
- Replace the air reservoir if
 - the air reservoir can be moved in the tensioning straps.
 - the air reservoir is damaged.
 - the type plate at the air reservoir is getting rusty, is loose or is missing.

2.10 Axles

As a basic principle, never overload the axles. Overloading axles reduces the service life of the axle bearings and causes damage to the axles.

Avoid:

- overloading the machine
- bumping into curbs
- exceeding the speed limit
- mounting wheels of incorrect inserting depth
- mounting wheels and tyres of incorrect dimensions

2.11 Environmental protection

Improper or careless use of hazardous substances may cause serious environmental pollution.

- Dispose of oils, greases and other auxiliary materials and consumables in accordance with the environmental regulations.
- Observe applicable local regulations regarding disposal.
- Observe the manufacturers' specification and safety data sheets for the individual substances.
- Additionally observe the specifications in the sub-suppliers' documentation.

2.12 Warranty and liability

As a basic principle, our "General Sales Terms and Delivery Conditions" shall apply. They have been handed over to the user upon conclusion of contract at the latest.

Any warranty and liability claims in case of personal injury and material damage will be excluded if they are due to one or several of the following reasons:

- Non-observance of these instructions
- Incorrect use
- Improper assembly, commissioning, operation and maintenance of the machine
- Operation of the machine with defective, improperly installed or inoperable safety and protective devices
- Unauthorised modifications and technical alterations
- Deployment of non-trained staff
- Neglected maintenance
- Insufficient inspection of machine parts subject to wear
- Improperly effected repairs
- Use of non-authorised spare parts
- Disasters due to foreign objects and force majeure

Technical modifications within the framework of an improvement and further development of the machine are reserved.

2.13 Safety and protective devices

Observe the following points, in order to ensure a sound condition and proper functioning of the safety and protective devices:

- Do not damage, modify, remove or disable protective devices. Increased risk of injury.
- It is not allowed to open protective devices
 - when the machine is powered.
 - as long as the tractor engine is running with the propeller shaft coupled / the hydraulic system connected.
 - if the ignition key is in the tractor and the tractor engine can be accidentally started with the propeller shaft coupled / the hydraulic system connected.
 - if tractor and machine have not been secured against accidental rolling by means of their respective parking brake and/or the chocks.
- Immediately replace missing or defective safety and protective devices.

The machine is equipped with the following safety and protective devices.

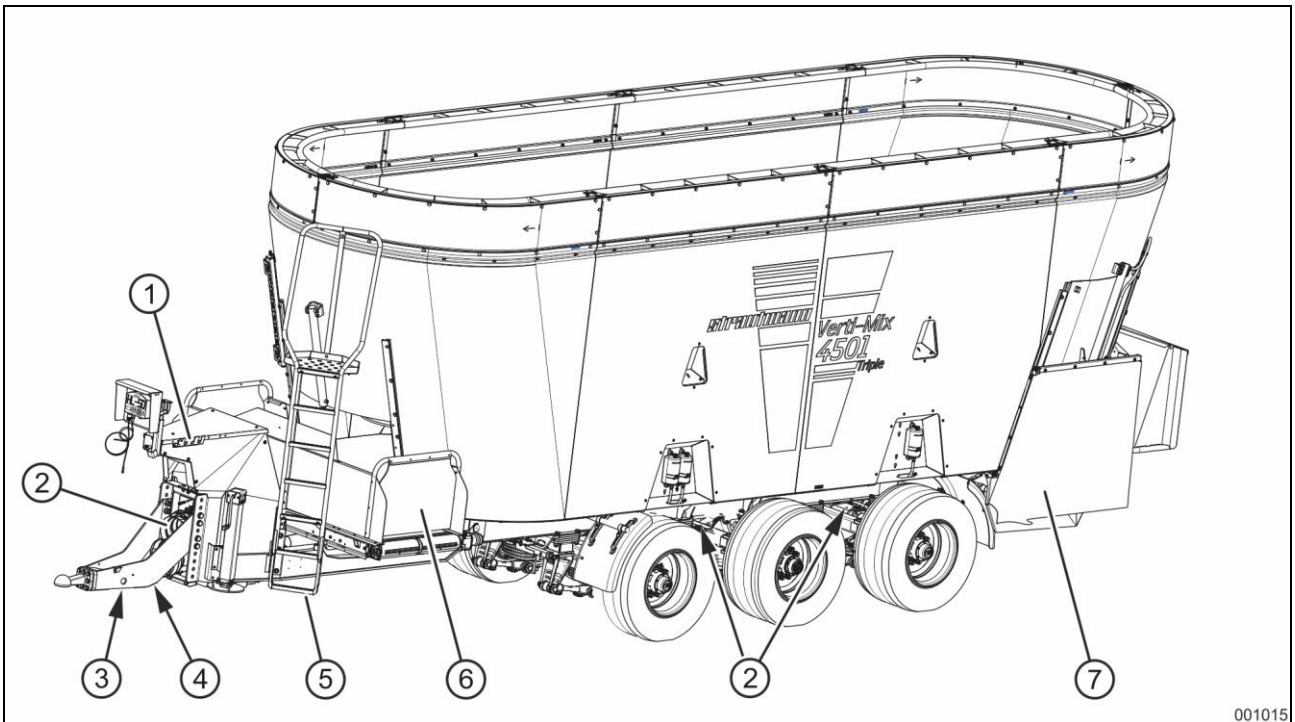
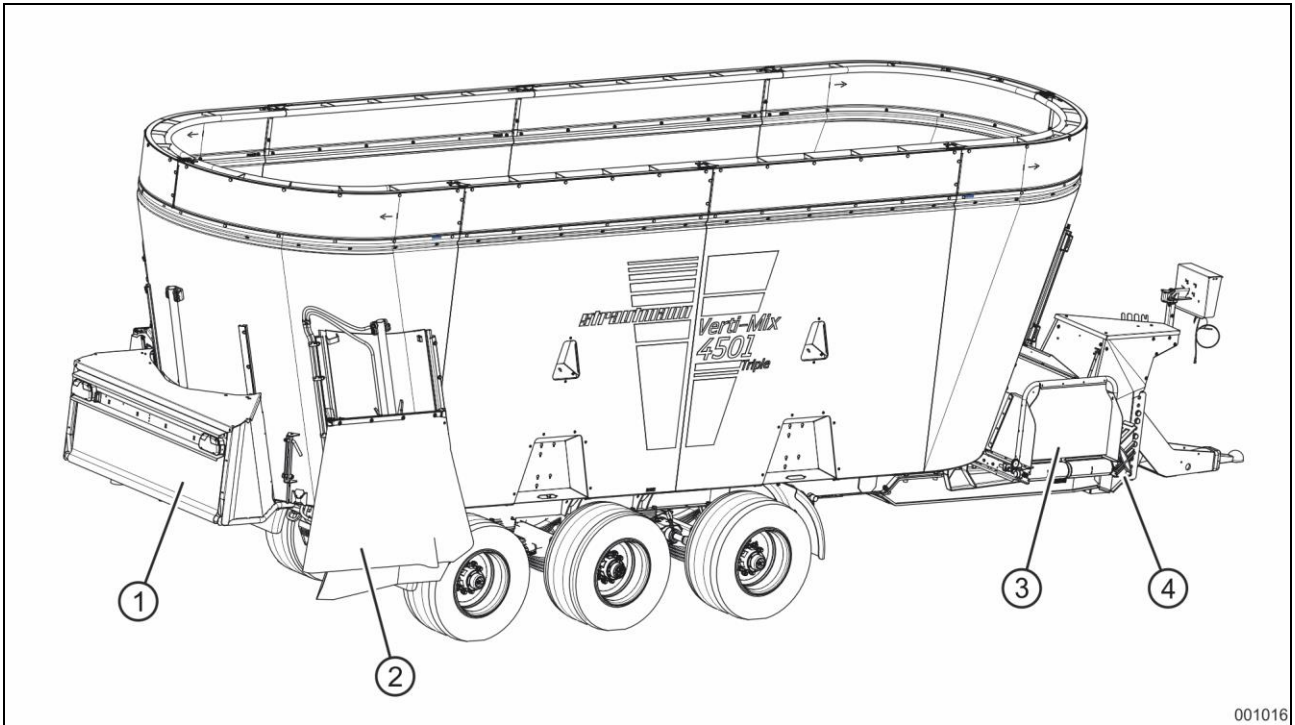

Fig. 1

- | | |
|--|---|
| <ul style="list-style-type: none"> 1 Hose holder for supply lines 2 Protective element for drive shaft 3 Propeller shaft holder 4 Protective devices for propeller shaft 5 Ladder, platform | <ul style="list-style-type: none"> 6 Protective device for crossover conveyor * 7 Protective device for rear side discharge (close-fitting, swivelling protective cover), for protection against accidental contact with the powered mixing auger |
|--|---|

* Optional extra



001016

Fig. 2

- | | |
|--|--|
| <ul style="list-style-type: none"> 1 Protective device, rear discharge * 2 Protective device for rear side discharge (close-fitting, swivelling protective cover), for protection against accidental contact with the powered mixing auger | <ul style="list-style-type: none"> 3 Protective device for crossover conveyor * 4 Chocks |
|--|--|

* Optional extra

2.14 Signs at the machine

Labels and signs may become soiled or otherwise unrecognisable. Thus, risks and important information may not be recognised and observed.

- Keep signs and labels in a clearly legible condition at all times.
- Do not remove or cover signs.

2.14.1 Warning signs

Warning signs mark dangerous spots on the machine and warn about residual risks.

A warning sign consists of two pictographs:

- 1 Pictograph for description of risk, surrounded by a triangular hazard symbol
- 2 Pictograph for avoidance of risk with illustrative instruction

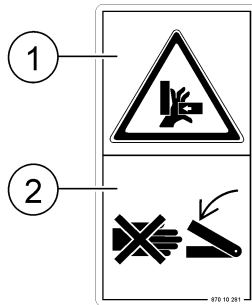

All warning signs attached to the machine include:

- Order number
- Description of risk
- Consequences in case of non-observance
- Instruction how to avoid the risk

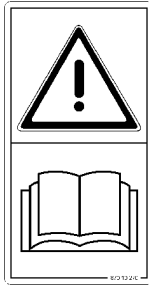

87010270

Please read and observe the operating and safety instructions before commissioning.

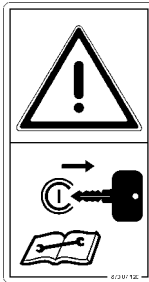

87007120

Accidental starting or rolling of tractor and machine

Risk of serious injuries or even death if accidental movements are triggered during mounting, setting, troubleshooting or maintenance work.

- Secure tractor and machine against accidental starting and rolling before carrying out any work on the machine.
- Observe the instructions in the respective chapters of the operating instructions depending on the work to be carried out.



87007117

Risk to the body of being drawn in or becoming entangled due to powered working tools

Powered working tools may cause serious injuries or even death.

- Never enter the cargo space as long as the tractor engine is running with the propeller shaft coupled / the hydraulic/electronic system connected.



87007123

Hydraulic oil squirting out under high pressure caused by leaking hydraulic hose pipes

Hydraulic oil squirting out under high pressure may penetrate the skin and enter the body, potentially causing serious injuries or even death.

- Never use your hand or fingers to seal leaks.
- Read and observe the operating instructions before carrying out service and maintenance work on hydraulic hose pipes.



87007126

Running-over of people due to accidental rolling of the machine parked in unsecured condition

Rolling machines may cause serious injuries or even death.

- Secure the machine against accidental rolling before unhitching the machine from the tractor or before parking the machine.
- Use the parking brake and/or chocks.



87007121

Falls of passengers on the machine

Unauthorised riding on steps or platforms may cause serious injuries or even death.

- Ensure that there are no passengers on the machine.
- Do not transport any objects on the machine.
- Never climb onto rolling machines.



87010276

Risk to the body of being drawn in or becoming entangled due to powered working tools

Powered working tools may cause serious injuries or even death.

- Keep an adequate safety distance from powered working tools.
- Keep people away from the hazardous area.



87010278

Risk of becoming entangled and wound up by powered propeller shaft

Rotating parts may entangle people and cause serious injuries or even death.

- Keep an adequate safety distance from the powered propeller shaft.
The risk exists as long as the tractor engine is running with the propeller shaft coupled.
- Keep people away from the hazardous area.



87007130

Risk of crushing to people standing between tractor and machine

Risk of serious injuries or even death within the swivelling range of the drawbar between tractor and hitched machine.

- Stop and secure tractor and machine against accidental rolling before carrying out any work on the machine
- Keep people away from the hazardous area.

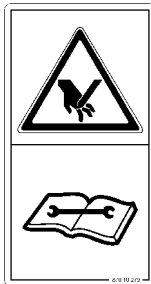

87010279

Risk of cuts for fingers and hands due to sharp working tools.

Sharp working tools may cause serious injuries including loss of limbs.

- Read and observe the operating instructions before carrying out work on working tools.
- Wear the prescribed protective equipment.



87010281

Risk of crushing of fingers and hands due to moving parts

Accessible moving parts may cause serious injuries including loss of limbs.

- Never reach into the hazardous area.
The risk exists as long as the tractor engine is running with the propeller shaft coupled / the hydraulic/electronic system connected.
- Keep an adequate safety distance from the hazardous area.



87010283

Substances flung out of the machine

Risk of serious injuries to people in the hazardous area due to substances or foreign objects being flung out of the machine.

- Keep an adequate safety distance from to the hazardous area.
- Keep people away from the hazardous area.



87010287

Breaking of load-bearing parts due to mechanical work on frame elements

Load-bearing parts may break due to mechanical work on frame elements. Risk of material damage and serious injuries or even death.

As a basic principle, the following is not allowed:

- Mechanical processing of the chassis
- Drilling at the frame or chassis
- Boring-up of existing holes at the frame or chassis
- Welding on load-bearing parts.



87012568

Falling from the top edge of the mixing container

Risk of serious injuries or even death when falling into the mixing container.

It is not allowed:

- to stay above the mixing container
- to bend over the mixing container
- to enter the mixing container from above.



87007552

Implants being affected by electromagnetic fields

The magnetic fields of the powerful permanent magnets may interfere with the functioning of active electronic implants such as pacemakers and defibrillators and cause harm to the health or even lead to the death of their wearers.

- Keep an adequate safety distance from magnets if you wear an electronic implant.
- Keep people with electronic implants away from the hazardous area.



87007557

Risk to the body of being drawn in or becoming entangled due to powered working tools

Powered working tools may cause serious injuries or even death.

- Never enter the cargo space as long as the tractor engine is running with the propeller shaft coupled / the hydraulic/electronic system connected.



87010271

Risk of crushing and impact to people standing within the hazardous area of the machine

Risk of serious injuries or even death to people within the hazardous area.

- People are not allowed within the hazardous area of the machine as long as the tractor engine is running.



87010280

Risk to hands or arms of being drawn in or becoming entangled by moving power transmission parts

Powered parts may cause serious injuries including loss of limbs.

- Keep protective devices closed as long as the tractor engine is running with the propeller shaft coupled / the hydraulic/electronic system connected.

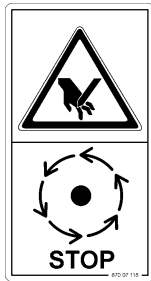

87007118

Risk of cuts for fingers and hands due to sharp, powered working tools

Sharp working tools may cause serious injuries including loss of limbs.

- Keep an adequate safety distance from the hazardous area.
- Keep people away from the hazardous area.
- Do not touch working tools until they have completely stopped.
- Keep protective devices closed as long as the tractor engine is running with the propeller shaft coupled / the hydraulic/electronic system connected.

2.14.2 Instruction signs

Instruction signs provide information referring to proper use of the machine.

An instruction sign consists of a pictograph.

- 1 Pictograph with visual or descriptive information or information summarised in a table

All instructions signs attached to the machine include:

- Order number
- Instruction or explanation how to use the machine properly

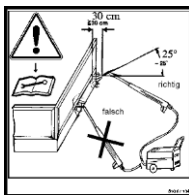
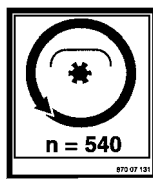
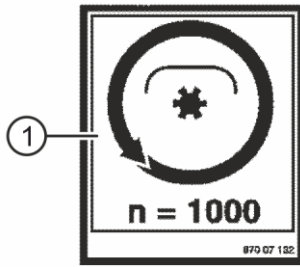

87007131

Required driving speed of the machine is 540 min⁻¹.

Before switching the propeller shaft on, check whether the selected speed and sense of rotation of the tractor's p.t.o. shaft have been adjusted to coincide with the admissible speed and sense of rotation of the machine.

87007134

Improper cleaning of the machine

It is imperative to observe the cleaning instructions when using a pressure washer/steam blaster for cleaning the machine.



87010288

Marks fixing points of lifting equipment (jack)



87706091

Marks lashing points for fixing lashing equipment when transporting the machine

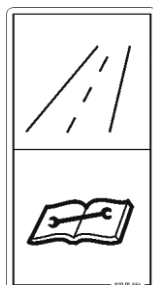

87007564

Read and observe the chapter "Transport Journeys" before travelling on public roads.

- ▶ see section 8.9, page 150

2.14.3 Placing of warning and instruction signs

The following figure illustrates the position of the warning and instruction signs on the machine.

Depending on the machine's equipment, more or less warning and instructions signs than shown here may be available.

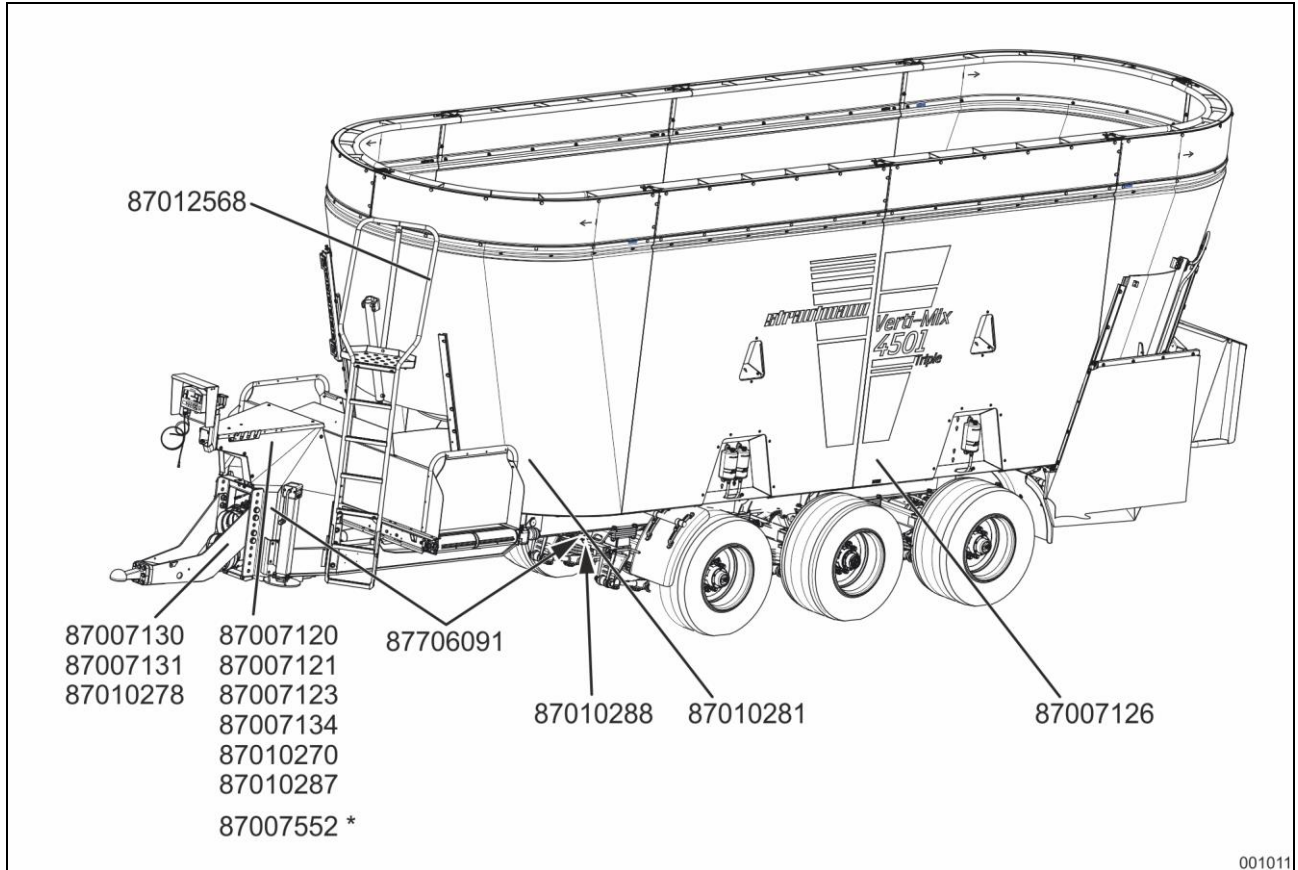

Fig. 3

001011

Placing of warning signs at the discharge outlets

Side discharge

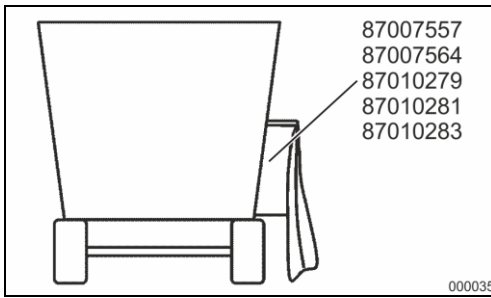

Fig. 4

Rear side discharge

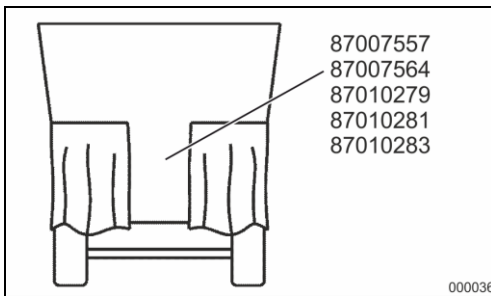

Fig. 5

Rear centre discharge

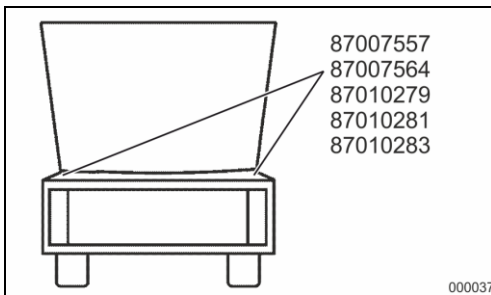

Fig. 6

Side discharge with side discharge conveyor

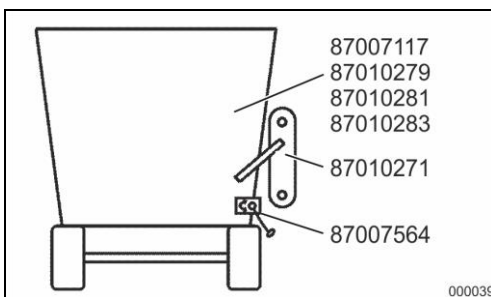
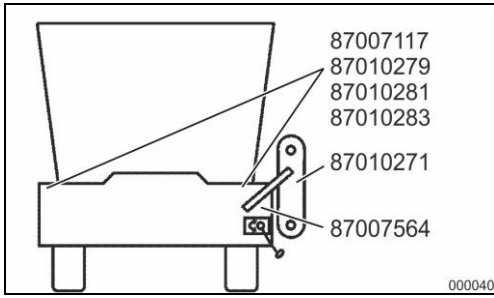
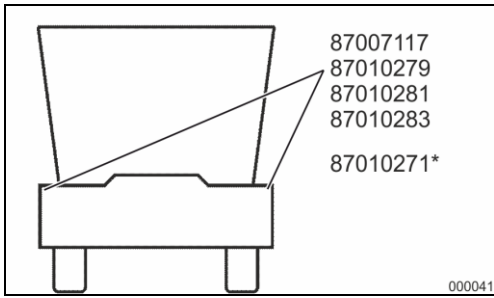

Fig. 7



Crossover conveyor with conveyor extension

Fig. 8



Crossover conveyor

Fig. 9

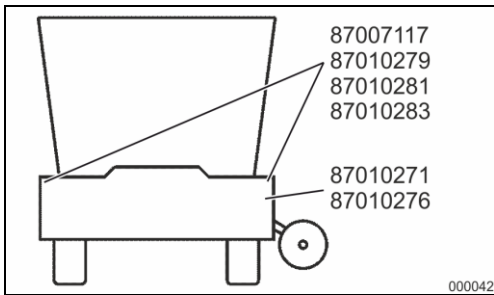

Crossover conveyor with fast bedding roller

Fig. 10

3 Technical data

3.1 General data

| Name | Unit | Verti-Mix Triple | | | | | |
|--|-------------------|--------------------------|-------|-------|---------------------|-------|-------|
| | | 3451 | | | 4501 | | |
| Usable mixing capacity * (payload) | m ³ | 28.5 | 31.5 | 34.5 | 38.0 | 41.5 | 45.0 |
| Extension height | m | – | 0.18 | 0.36 | – | 0.18 | 0.36 |
| Gross vehicle weight rating | | | | | | | |
| 25 km/h | | | | | | | |
| • Tandem axle | kg | 20000 | | | – | | |
| • Tridem axle | | 26000 | | | 26000 | | |
| Technical gross vehicle weight rating up to 15 km/h | | | | | | | |
| • Tandem | kg | 26000 ¹⁾ | | | – | | |
| • Tridem | | 38000 ²⁾ | | | 38000 ²⁾ | | |
| Admissible axle load | | | | | | | |
| • Tandem | kg | 9000 | | | – | | |
| • Tridem | | 8000 | | | 8000 | | |
| Admissible tongue load | kg | 2000 | | | 2000 | | |
| Dead weight (approx.) | | | | | | | |
| • with crossover conveyor | kg | 11174 | 11287 | 11400 | 13658 | 13779 | 13900 |
| • with two-sided discharge | kg | 10874 | 10987 | 11100 | 13358 | 13479 | 13600 |
| Power required with switchgear | | | | | | | |
| • 14 min ⁻¹ | kW | 88 | 94 | 100 | – | – | – |
| • 26 min ⁻¹ | | 144 | 153 | 163 | – | – | – |
| • 16 min ⁻¹ | kW | 109 | 115 | 123 | – | – | – |
| • 30 min ⁻¹ | | 177 | 188 | 201 | – | – | – |
| • 13 min ⁻¹ | kW | – | – | – | 114 | 120 | 145 |
| • 23 min ⁻¹ | | – | – | – | 186 | 196 | 236 |
| Maximum operating pressure | bar | 210 | | | | | |
| Oil flow rate | l/min | 25 – 45 | | | | | |
| Power supply weighing device / lighting system / electro-hydraulic control set | volt | 12 VDC | | | | | |
| P.t.o. speed | min ⁻¹ | 540 / 1000 ³⁾ | | | | | |
| Sound pressure level | dB(A) | ≤ 84 | | | | | |

Tab. 4: General data

* Actually usable mixing capacity, mixing augers having been deducted from the capacity

¹⁾ Reduction of the technical gross vehicle weight rating to 23600 kg by means of 435 tyres

²⁾ Reduction of the technical gross vehicle weight rating to 34400 kg by means of 435 tyres

³⁾ 540 min⁻¹ with mechanical switchgear and 2-gear power shift gearbox, 1000 min⁻¹ with 3-gear power shift gearbox

3.2 Dimensions of wagon

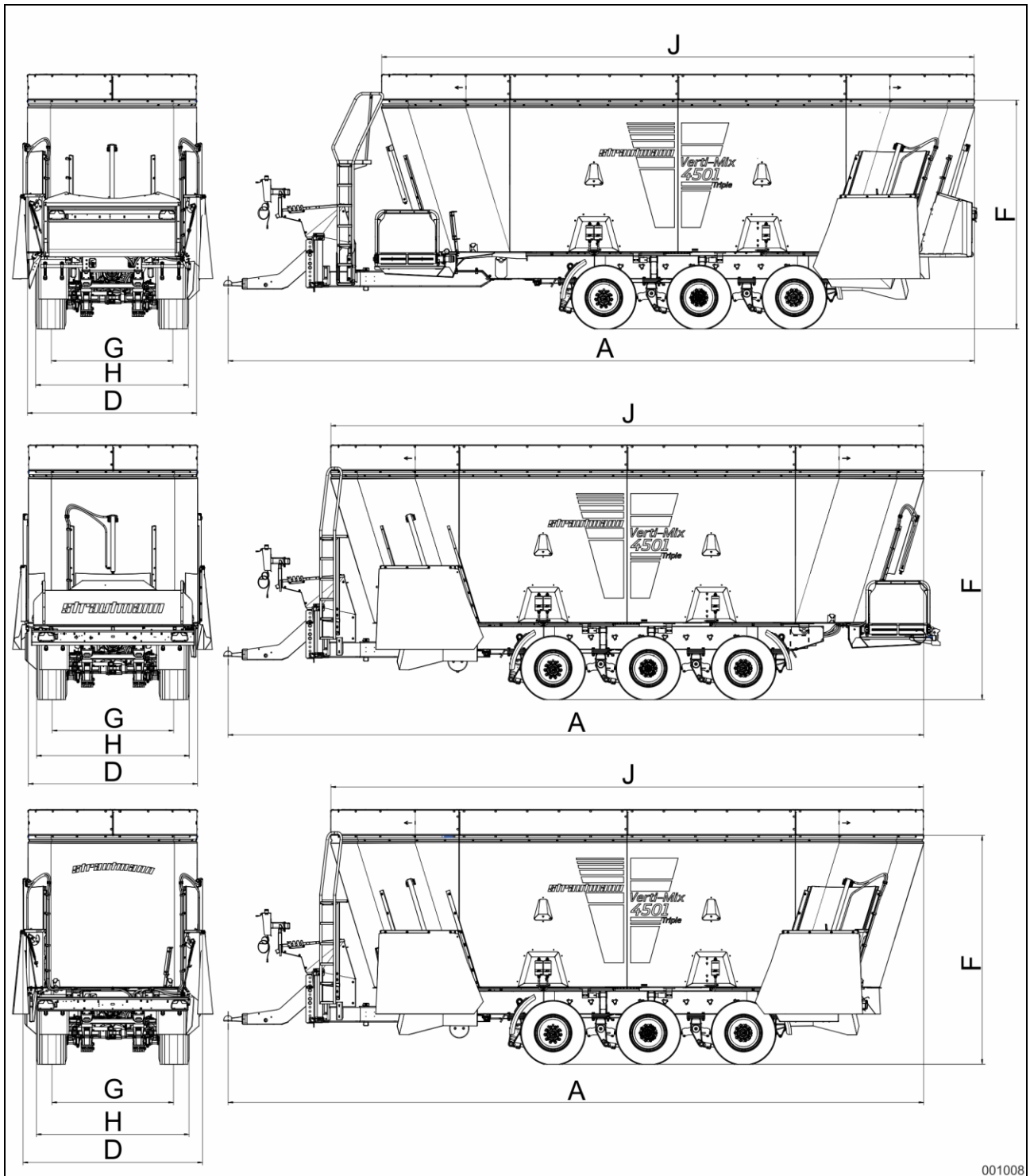

001008

Fig. 11

| Name | Unit | Verti-Mix Triple | | | | | |
|--|------|------------------------|------|------|------------------------|------|------|
| | | 3451 | | | 4501 | | |
| Extension height | m | – | 0.18 | 0.36 | – | 0.18 | 0.36 |
| Dimensions | | with 455/45R22.5 tyres | | | with 435/50R19.5 tyres | | |
| Length: Measured from the centre of the drawbar lug ¹⁾ | | | | | | | |
| • A = with front crossover conveyor | m | 10.15 | | | 10.66 | | |
| • B = with front + rear crossover conveyor ²⁾ | m | 10.36 | | | 10.77 | | |
| • C = without crossover conveyor | m | 9.43 | | | 9.94 | | |
| Up to the middle of the chassis without front crossover conveyor | m | 5.86 | | | 6.00 | | |
| Up to the middle of the chassis with front crossover conveyor | m | 6.59 | | | 6.72 | | |
| Width | | | | | | | |
| • D = with crossover conveyor | m | 2.28 | | | 2.42 | | |
| • E = with right-hand or left-hand side discharge | m | 2.38 | | | 2.52 | | |
| • E = with side discharge on both sides | m | 2.48 | | | 2.62 | | |
| Height incl. tyres: Tandem and tridem axle | | | | | | | |
| • F = with 235/75R17.5 | m | 2.78 | 2.96 | 3.14 | 3.08 | 3.26 | 3.44 |
| • F = with 435/50R19.5 | m | 2.90 | 3.08 | 3.26 | 3.20 | 3.38 | 3.56 |
| • F = with 455/45R22.5 | m | 2.96 | 3.14 | 3.32 | 3.26 | 3.44 | 3.62 |
| Wheelbase | m | 1.36 | | | 1.36 | | |
| G = Track | m | 1.73 | | | 1.73 | | |
| H = Outside wheel width incl. standard tyres: | m | 2.185 ³⁾ | | | 2.165 ³⁾ | | |
| J = Container length (inner container dimension incl. overflow ring) | m | 7.48 | | | 8.09 | | |
| Discharge height with crossover conveyor | m | 1.09 ⁴⁾ | | | 1.04 ⁵⁾ | | |

Tab. 5: Vehicle dimensions

¹⁾ + 0.42 m with forced steering axle system

²⁾ + 0,13 m with lighting

³⁾ depending on the tyres: with 455 tyres 2.185 m, with 435 tyres 2.165 m

⁴⁾ with 455 tyres

⁵⁾ with 435 tyres

4 Description of machine

The machine is a fodder mixing wagon facilitating the labour-intensive process in dairy cattle feeding. It serves to chop, homogeneously mix, transport and discharge silage and usual fodders used in keeping livestock.

The machine is usually filled by means of a tractor with front loader, telescopic loader, yard or wheeled loader.

Furthermore, the machine can be filled by means of feeding aids such as a feed hopper or directly from the pipe or conveying device of the fodder.

This chapter provides comprehensive information about the design and function of the machine.

The machines are available with various optional extras. Due to the individual equipment of your machine, not all descriptions included in these operating instructions apply to your machine. Optional extras are marked in these operating instructions and are available at extra cost.

4.1 General overview

Fig. 12

- | | |
|--|--|
| 1 Drawbar | 11 Container extension |
| 2 Plug deposit for supply lines | 12 Rear discharge |
| 3 Control set for weighing device * | 13 Side discharge |
| 4 Opening scale for dosage gate | 14 Braking axle |
| 5 Pointer for opening width of dosage gate | 15 Wheels |
| 6 Mixing container | 16 Compensating reservoir for gear lubricant oil |
| 7 Mixing augers, with magnetic system where applicable * | 17 Counter-cutter, mechanical or hydraulic * |
| 8 Rear-view camera * | 18 Crossover conveyor * |
| 9 Work lights * | 19 Ladder, platform |
| 10 Overflow ring | 20 Supporting leg |
| | 21 Propeller shaft coupling |
- * Optional extra

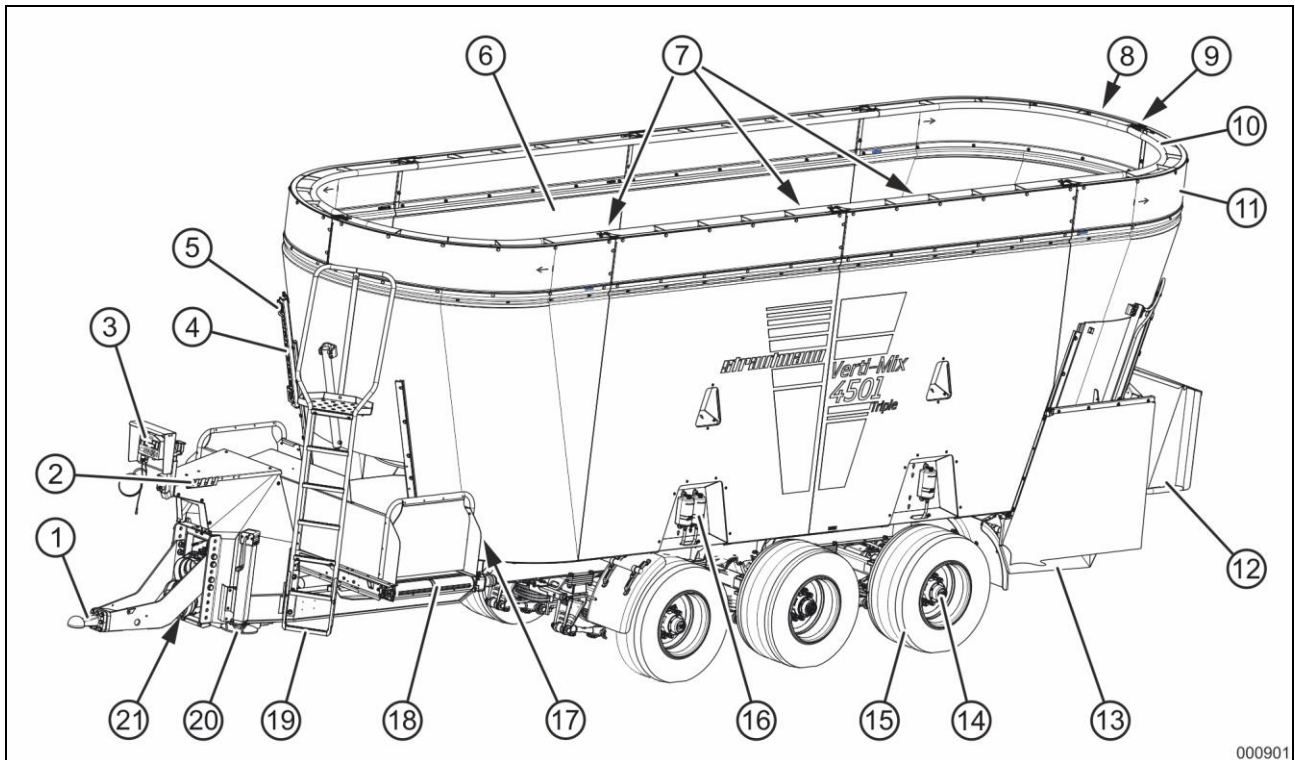
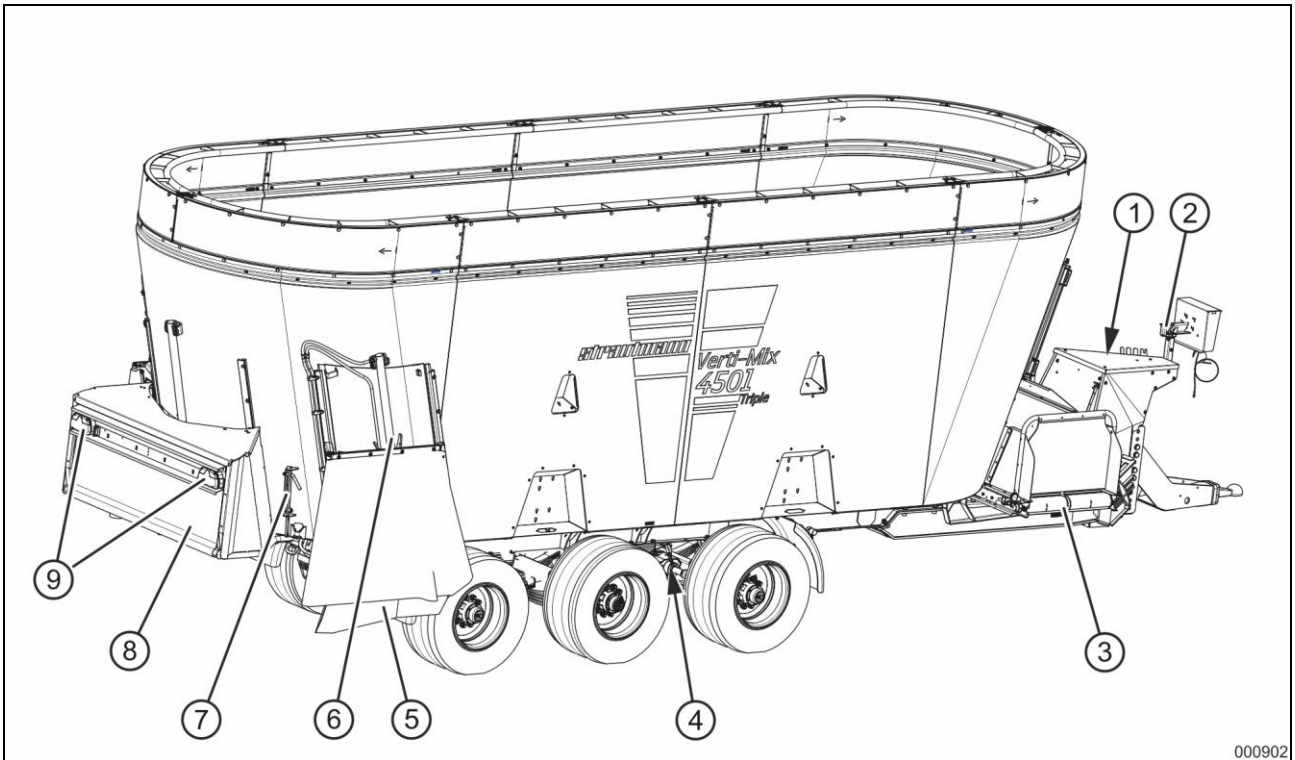

Fig. 13

- | | | | |
|---|-------------------------------------|---|---|
| 1 | Electro-hydraulic control block * | 6 | Dosage gate |
| 2 | Swivelling holder for control set | 7 | Counter-cutter, mechanical or hydraulic * |
| 3 | Crossover conveyor * | 8 | Rear discharge |
| 4 | Angular gear for mixing auger drive | 9 | Lighting (multi-function lights) |
| 5 | Side discharge | | |

* Optional extra

4.2 Chassis

Depending on the machine's equipment, the chassis consists of a tandem or tridem chassis with mechanical suspension:

- with passive steering
- with forced steering
- with compressed-air brake system
- with hydraulic service brake

4.2.1 Chassis with mechanical suspension

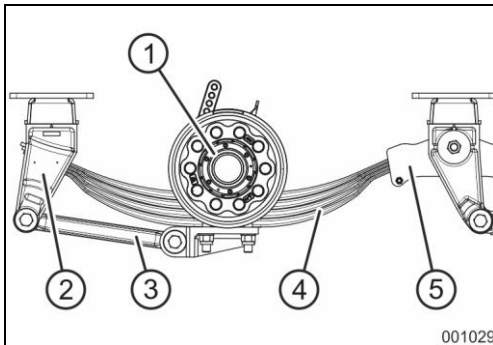

Fig. 14

The chassis equipped with parabolic springs (4) is very robust and ensures static axle load compensation between the axles by means of oscillating arms.

Due to its design, the suspension has an internal damping function and does not require additional shock absorbers.

The axles are connected to the vehicle frame by means of connecting rods (3), supports (1) and oscillating arms (5).

Separate connecting rods (3), which can be adjusted for easy setting of the track, guide the axles (1).

4.3 Steering axle

4.3.1 Passive steering axle

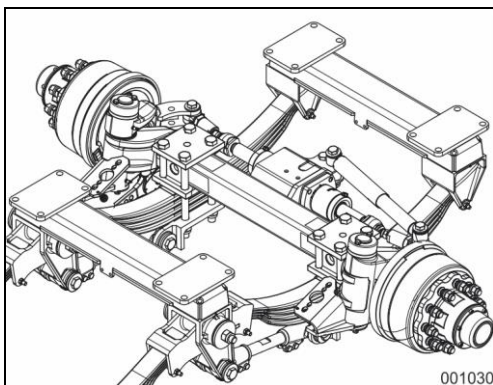

Fig. 15

In unlocked condition, the passive steering axle can move freely and follows the turning radius of the corner during cornering, thus improving the manoeuvrability and reducing tyre wear during cornering on paved areas.

As the passive steering axle is passively steered when cornering the tractor, the axle must be locked during reverse travel. Otherwise, the machine cannot be steered in a controlled way. Furthermore, the passive steering axle can be locked, in order to achieve improved driving stability at higher speeds.

The passive steering axle is unlocked and locked from the tractor via remote control. Unlocking and locking is directly carried out via a single-acting control device of the tractor.

4.3.2 Forced steering axle system

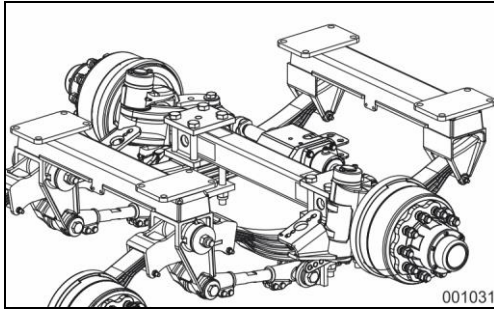

Fig. 16

The forced steering axles are hydraulically actuated depending on the tractor's cornering.

The use of the forced steering axle system reduces the steering forces, in particular during reverse travel. The driving comfort is increased and the tyre wear considerably reduced.

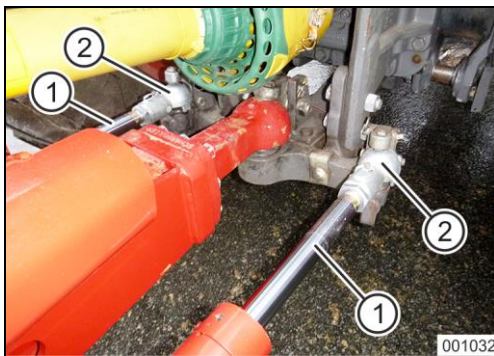

Fig. 17

The forced steering axle system is controlled via hydraulic cylinders (1) connected to the tractor by means of a ball-type coupling (2).

The steering angle of the tractor is transmitted to the steering axles of the chassis by means of the hydraulic cylinders of the forced steering axle system; on a tandem chassis, the steering axle is the rear axle, on a tridem chassis the steering axles are the front and rear axle.

4.4 Hydraulic system

The hydraulic system consists of the following basic components:

- Hydraulic motors
- Hydraulic valve with pressure limiter
- Hydraulic cylinder
- Hydraulic oil tank
- Hydraulic pipes and connecting parts

The hydraulic system is powered by the tractor's hydraulic pump. The hydraulic pump presses the hydraulic oil out of the hydraulic oil tank into the hydraulic cylinders and to the hydraulic motors. The hydraulic oil flows through a return-flow filter back into the hydraulic oil tank.

The hydraulic components are controlled by means of inserted control elements alternatively:

- directly via the control devices of the tractor (standard equipment),
- via Bowden cable operation or
- electro-hydraulically (E-control operation)

4.5 Connections

The following figure illustrates the connections or supply lines between tractor and machine.

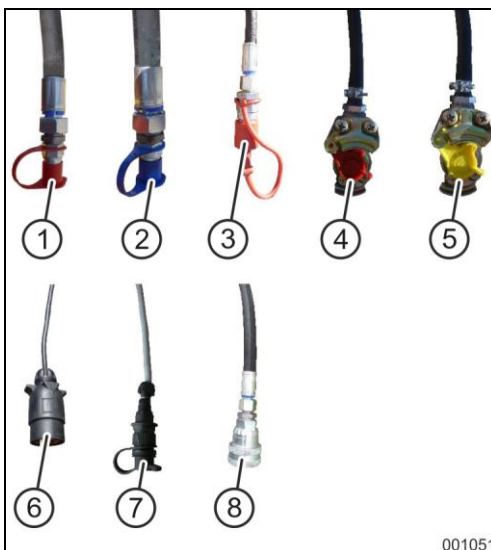

Fig. 18

- 1 Hydraulic connector "Flow line" SN 16 (red)
- 2 Hydraulic connector "Return line" SN 20 (blue)
- 3 Load-sensing connector SN 6 (only with available load-sensing connection)
- 4 Compressed-air brake system, feed line (red)
- 5 Compressed-air brake system, brake line (yellow)
- 6 Lighting connector 7-pole
- 7 Power supply 3-pole
- 8 Hydraulic connector for hydraulic brake system with hydraulic clutch according to ISO 5676 (only with available hydraulic brake system)

4.6 Drawbar

The machine is equipped with a vertically adjustable drawbar for:

- Top linkage with flanged drawbar 40 mm according to DIN 74054-1/2 / ISO 8755
- Top linkage with flanged and cranked drawbar lug 40 mm
- Top linkage with coupling head type 80
- Bottom linkage with coupling head type 80
- Bottom linkage with flanged drawbar lug type 3394 and fixed supporting leg
- Bottom linkage with flanged drawbar lug 50 mm according to DIN 74053-1 / ISO 1102

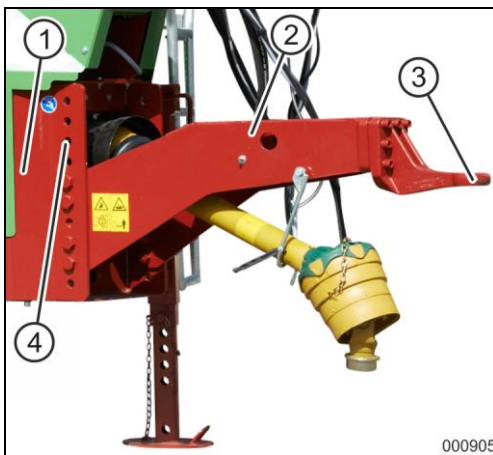

Fig. 19

- 1 Chassis
- 2 Drawbar
- 3 Drawbar lug
- 4 Positioning holes (height adjustment)

The drawbar (2) is screwed to the chassis (1). The height adjustment is carried out by means of positioning holes (4).

This allows optimum adjustment of the drawbar lug (3) to the respective height of the coupling device of the different tractors.

The drawbar lug (3) is coupled by means of an appropriate trailer hitch, which may be a bolt-type or ball-type coupling.

4.7 Brake system

Depending on the machine's equipment, the brake system is

- a hydraulic working brake with parking brake for an admissible maximum speed of 6 km/h.
- a compressed-air brake system with manually operated brake pressure regulator and parking brake for an admissible maximum speed of 25 km/h or 40 km/h. The compressed-air brake is designed as a dual-line compressed-air brake system.
- a hydraulic service brake system with parking brake for an admissible maximum speed of 25 km/h. The hydraulic service brake system has been designed for connection to a controlled hydraulic service brake system of a tractor.

4.7.1 Hydraulic working brake

The hydraulic working brake serves to slow down the movement of the machine, but is, however, not licensed for public road traffic. The admissible maximum speed is 6 km/h. A machine equipped with a hydraulic working brake is intended for yard use only.

The working brake is connected to a single-acting control device or a double-acting control device with neutral position of the tractor. The operator must actuate the respective control device on the tractor in order to slow the machine down.

4.7.2 Hydraulic service brake

The use of the hydraulic service brake ensures an even brake pressure being exerted on all wheels. The controlled hydraulic brake system is connected to the special brake valve of the tractor. Actuation of the brake pedal moves a hydraulic piston in the main brake cylinder transmitting the force into a pressure of the brake fluid in the hydraulic pipe. This pressure acts on the pistons in the wheel brake cylinders which then exert the forces on the brake shoes and move them; the machine decelerates.

NOTE

A hydraulic service brake system has not been licensed for Germany.

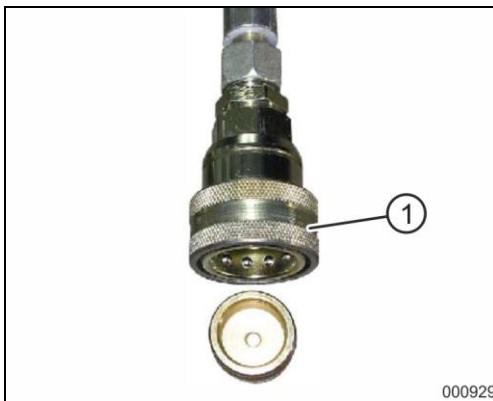

Fig. 20

- 1 Hydraulic sleeve ISO 5676

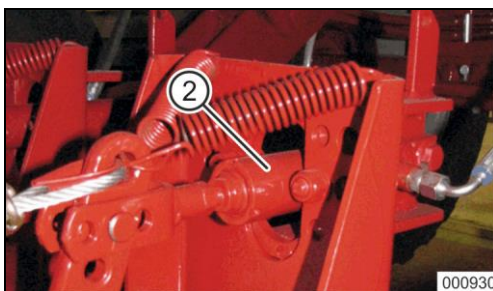

Fig. 21

- 2 Hydraulic cylinder of braking axle

4.7.3 Compressed-air brake system

When using the compressed-air brake system, the wheel brakes are actuated pneumatically. The compressed air is supplied via connecting hoses from the tractor. The supply line marked in red serves to permanently provide the hitched machine with air, while the brake line marked in yellow is responsible for the control of the braking process.

Use the manual brake pressure regulator to manually pre-select the brake force and adapt it to the filling degree of the machine.

The brake system consists of:

- 1 Brake line with hose coupling (yellow)
- 2 Feed line with hose coupling (red)
- 3 In-line filter of brake line
- 4 In-line filter of feed line
- 5 Trailer brake valve with brake pressure regulator
- 6 Membrane cylinder
- 7 Test connection for membrane cylinder
- 8 Compressed-air reservoir
- 9 Drain valve
- 10 Test connection for compressed-air reservoir

NOTE

Observance of the maintenance intervals is indispensable for proper functioning of the compressed-air brake system.

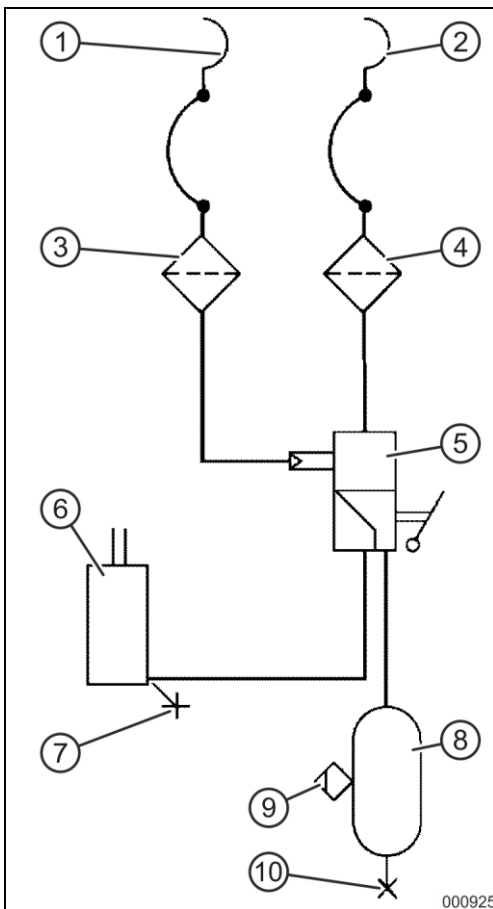

Fig. 22

4.7.4 Parking brake

The applied parking brake secures the unhitched machine against rolling. The parking brake is actuated by turning the crank handle via spindle and cable.

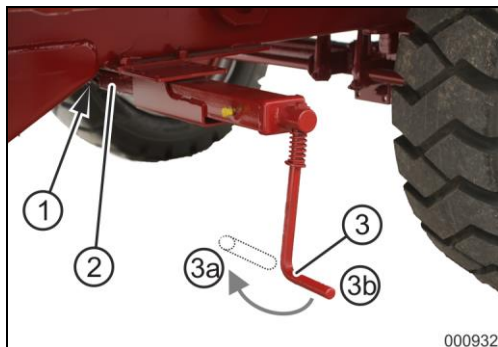

Fig. 23

- 1 Cable
- 2 Spindle
- 3 Crank handle (in adjustment position)
- 3a Rest position, swivelled by 180° compared to the adjustment position
- 3b Adjustment position

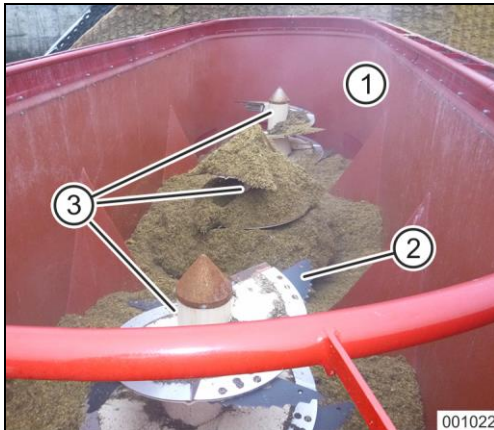

Fig. 24

4.8 Mixing container and mixing augers

In the mixing container (1), the fodder is picked up and chopped and mixed by the mixing augers (3) during the mixing process. The mixing augers are powered via angular gears coupled with the power train.

The mixing augers are equipped with cutting knives (2) which loosen the bales and chop the fodder. The knives can be adjusted and thus be optimally set to the specific conditions of use. Furthermore, the counter-cutters mounted at the side of the mixing container can be extended, e.g. when chopping and mixing round or cuboid bales. Highly-structured fodder components can be chopped more finely and mixed faster.

Due to the geometry of the container and mixing augers, a homogeneous mixture of fodder and fodder components is obtained.

The capacity of the mixing container can be increased by means of a container extension on request. Moreover, a container extension prevents fodder from being thrown out. However, do not fill the mixing container completely up to the newly gained capacity.

4.8.1 Feed funnel for mineral feed

Optional extra

Pourable mineral feed or other pourable fodder additives can easily be filled into the mixing container from the ground through the feed hopper (1) mounted at the container.

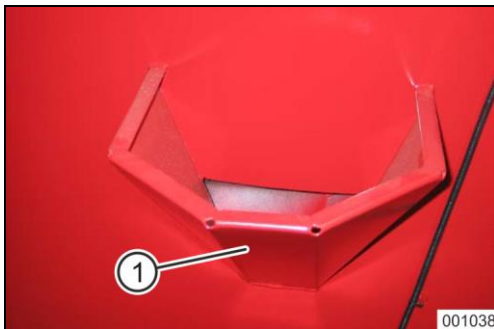

Fig. 25

4.8.2 Magnetic system

Optional extra

The magnetic system consists of two powerful magnetic blocks (1) at the mixing auger.

The permanent magnets keep the fodder mixture free from pointed and sharp-edged foreign objects. Iron particles (nails, loose wire fragments etc.) stick to the magnets and can be removed later.



Fig. 26

4.9 Discharge options

After completion of the mixing process, the fodder mixture is conveyed through the discharge openings of the mixing container and discharged for feeding the animals via the discharge conveyors.

The following discharge options are available for fodder discharge:



Fig. 27

Front crossover conveyor



Fig. 28

Rear crossover conveyor

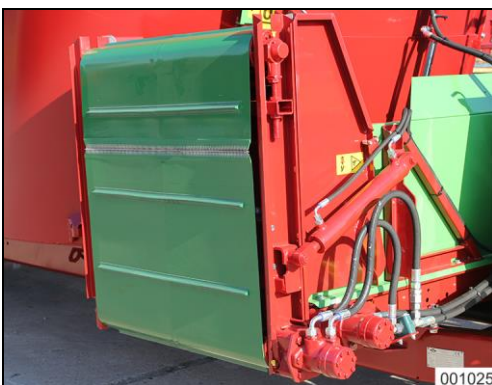

Fig. 29

Crossover conveyor with extension



Side discharge with guard

Fig. 30



Side discharge with extension

Fig. 31



Rear discharge, fodder discharge behind the wheel

Fig. 32

4.10 Traffic-related equipment

Properly fix and check the traffic-related equipment for proper functioning before travelling on public roads and paths.

Depending on the machine's equipment, it is fitted with:

- a lighting and identification system according to the national road traffic regulations
- a brake system, ► see section 6.13, page 102.

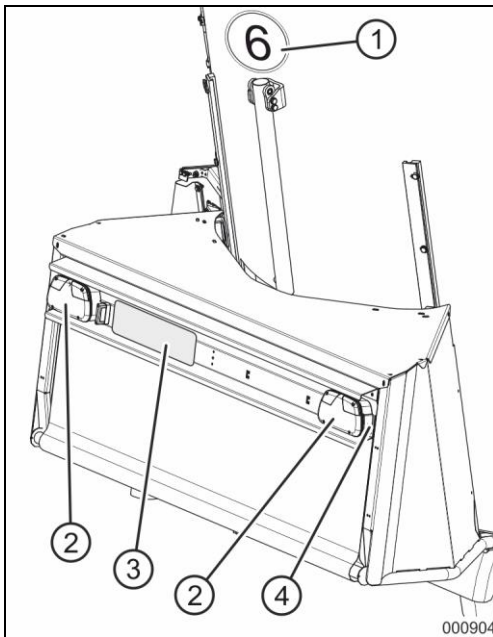

Fig. 33

- 1 Speed sign
- 2 Multifunction light with triangular reflector
- 3 License plate
- 4 Side reflectors

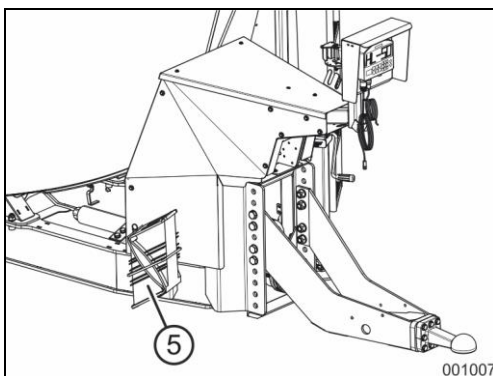

Fig. 34

- 5 Chocks

4.11 Type plate

The marking of the machine is treated as a document and must not be altered or made unrecognisable.



Fig. 35

- 1 Type plate with CE symbol
- 2 Vehicle identification number (machine ID number) embossed into the frame



| | | | | | |
|---|------------|--|--|---|---------------------------------|
|  | | P. Strautmann & Söhne GmbH u. Co. KG Bielerfelder Straße 53 D-49196 Bad Laer | |  | |
| Fahrzeug Waschinen | Ident.-Nr. | <input type="text" value="3"/> | | | |
| Typ | | <input type="text" value="4"/> | | | |
| Leergewicht | kg | <input type="text" value="5"/> | | Baujahr | <input type="text" value="10"/> |
| Zul. Gesamtgewicht | kg | <input type="text" value="6"/> | | Nennrehzahl | <input type="text" value="11"/> |
| Zul. Stützlast | kg | <input type="text" value="7"/> | | Zul. Hydr. Druck | <input type="text" value="12"/> |
| Zul. Achslast vom | kg | <input type="text" value="8"/> | | Zul. Höchstgeschw. | <input type="text" value="13"/> |
| Zul. Achslast hint. | kg | <input type="text" value="9"/> | | | |
| Genehmigungs-Nr. | | <input type="text"/> | | | |

Fig. 36

Information on the type plate:

- 1 Manufacturer
- 2 CE symbol
- 3 Vehicle/Machine ID number
- 4 Model
- 5 Empty weight [kg]
- 6 Gross vehicle weight rating [kg]
- 7 Admissible tongue load/front axle load [kg]
- 8 Admissible rear axle load [kg]
- 9 Approval number
- 10 Year of manufacture
- 11 Rated speed [min^{-1}]
- 12 Admissible hydraulic pressure [bar]
- 13 Maximum admissible speed [km/h]

5 Transport

5.1 Safety

This work requires special know-how and/or specific technical equipment.

Operative staff:

Qualified staff for load transport (haulage contractor, crane operator)

Loading/Unloading by means of lifting devices

- Only authorise duly qualified staff to lift loads and instruct crane operators.
- Only use lifting, transport and load handling equipment and slings with sufficient lifting capacity and in technically sound condition for transport.
- Check all anchorage points and slings before each use for possible damage and replace them if necessary.
- Exclusively use the marked anchorage points when fixing slings.
- Secure loading areas against unauthorised access.
- Move loads only under supervision.

⚠ DANGER

Suspended loads

Tilting or falling loads may cause serious or even fatal injuries.

- Never stand beneath suspended loads.
 - Observe the total weight, anchorage points and the centre of gravity of the load.
 - Observe the transport instructions and symbols on the load to be transported.
-

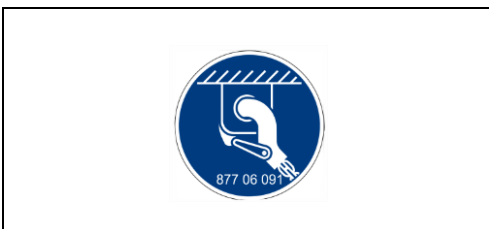

Fig. 37

Lashing and anchorage points for fixing slings and lashing loads are identified by the adjacent pictograph.

Loading/Unloading by means of tractor

- The tractor must meet the performance requirements and be able to safely decelerate the machine.
- If the machine is equipped with a compressed-air brake system, start moving the machine only when the pressure gauge on the tractor indicates 5 bar.

⚠ WARNING

Uncontrolled movements due to tractor

Insufficient stability and insufficient steerability and braking ability of the tractor may cause dangerous tractor and machine movements.

- Properly hitch the machine only to an appropriate tractor.

5.2 Lashing and anchorage points

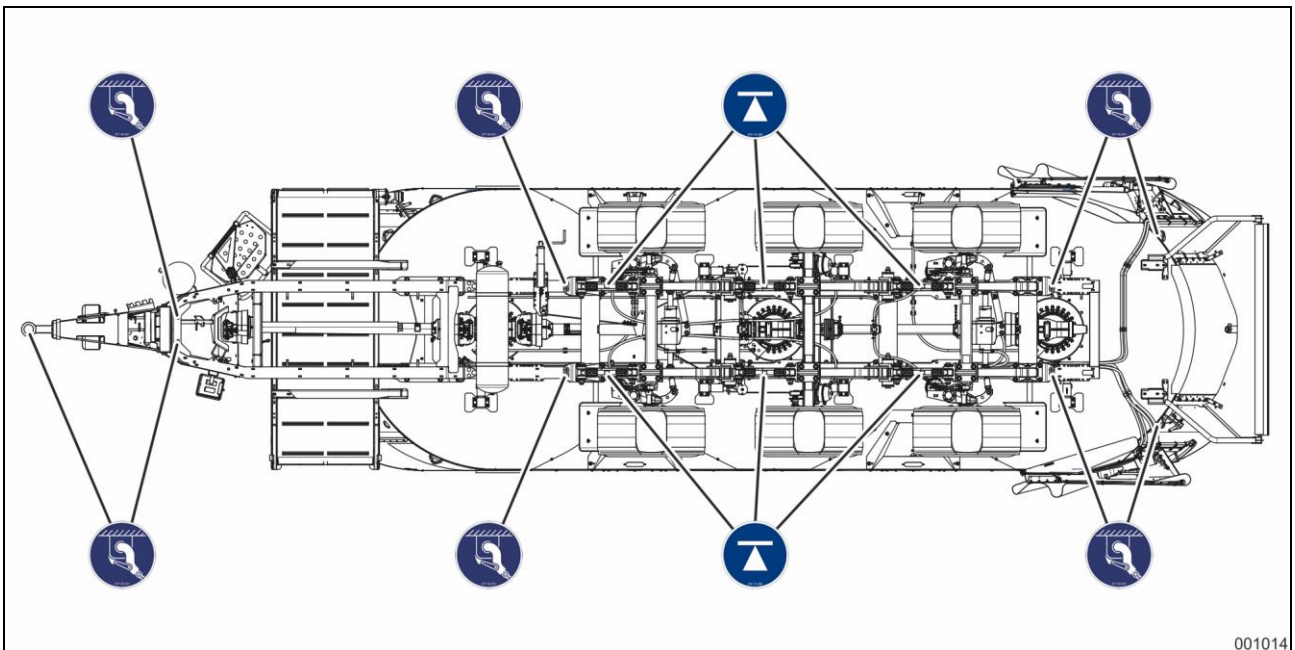

001014

Fig. 38



Lashing and anchorage points



Application points for lifting device (jack)

6 Commissioning

6.1 Safety

As a basic principle, the following is applicable:

- Observe the national road traffic regulations.
- Before each start-up, the operator must check the tractor and the machine for their road and operational safety.

6.1.1 Road traffic regulations

NOTE

The following points apply to Germany. When using the machine in other countries, observe the respective applicable national regulations and laws.

The standard machine model does not have a certificate for motor vehicle traffic.

The maximum admissible speed is 6 km/h.

In terms of the StVZO the machine is a hitched farming or forestry machine.

Farming or forestry equipment:

- with a gross vehicle weight rating of more than 3 t requires an operating license for travelling on public roads. An operating license is not required if the maximum admissible speed is 6 km/h.
- is not subject to license (no license plate, no technical supervision) in case of:
 - exclusive use in farming and forestry establishments
 - exclusive use for farming or forestry purposes.
- must be equipped with the second license plate of one of the farm's tractors if it is not subject to license.
- is subject to license for commercial use, e. g. by contractors (license plate, technical supervision).
- must be equipped with proper lighting and marking when travelling on public roads.

6.2 Tractor's compatibility

Incorrect use of the tractor may cause risks due to failure of components.

- Do not exceed the following admissible limit values:
 - Total weight of the tractor
 - Axle loads of the tractor
 - Tongue load at the tractor's coupling point
 - Towing capacity of the coupling device
 - Load-bearing capacity of the tractor tyres
- The gross vehicle weight rating of the tractor, which is specified in the vehicle registration certificate, must exceed the sum of:
 - the tractor's empty weight
 - the ballasting mass
 - the tongue load of the hitched machine
- The tractor's front axle load must never fall below 20 % of the tractor's empty weight.
- The tractor must reach the deceleration specified by the tractor's manufacturer even with the machine attached/hitched up. Perform a braking test.
- Equip the tractor with mirrors if necessary, such that the hazardous areas on both sides of the machine are clearly visible from the tractor.

6.3 Required tractor equipment

The tractor used must meet the following requirements, in order to ensure correct use of the machine:

| Engine output of tractor | |
|--|--|
| For the necessary power requirement, please refer to the chapter "Technical data". | |

Tab. 6: Engine output

| Electrical system | |
|------------------------|--|
| Battery voltage | 12 V |
| Socket for lighting | 7-pole |
| Socket for control set | 3-pole (DIN 9680) The feed line of the 3-pole socket must have a minimum cable cross section of 4 mm ² . |

Tab. 7: Electrical system

| Hydraulic system | |
|---------------------------------|---|
| Maximum operating pressure | 210 bar |
| Delivery rate of hydraulic pump | Min. 25 l/min and max. 45 l/min at 180 bar |
| Hydraulic oil of machine | ATF hydraulic oil ATTENTION – Damage due to mixing of hydraulic oils. Check the compatibility of the hydraulic oils before connecting the machine to the hydraulic system of the tractor. Contact the agricultural machinery dealer to check if necessary. Never mix different types of hydraulic oil. |

Tab. 8: Hydraulic system

NOTE

Depending on their function, the hydraulic components can be connected to

- a double-acting control device
- a single-acting control device and a depressurised return line leading directly into the hydraulic oil tank of the tractor

Given a free choice, we recommend a single-acting control device and a depressurised return line. The hydraulic oil flows back into the hydraulic oil tank of the tractor through the free return line with a low back pressure. Thus, a free return line reduces heating-up of the hydraulic oil.

| Operation via direct connection | |
|--|---|
| Hydraulic component | Required control devices on the tractor |
| Dosage gate | <ul style="list-style-type: none"> • Double-acting control device |
| Hydraulic supporting leg | <ul style="list-style-type: none"> • Double-acting control device |
| Hydraulic counter-cutters | <ul style="list-style-type: none"> • Double-acting control device |
| Hydraulic motor for crossover conveyor | Optional: <ul style="list-style-type: none"> • Double-acting control device or • single-acting control device and depressurised return line (max. back pressure in return line 5 bar) |
| Side discharge conveyor | <ul style="list-style-type: none"> • Double-acting control device (folding in and out) |
| Hydraulic motor for side discharge conveyor: | Optional: <ul style="list-style-type: none"> • Double-acting control device or • single-acting control device and depressurised return line (max. back pressure in return line 5 bar) |
| Conveyor extension | <ul style="list-style-type: none"> • Double-acting control device (folding in and out) |

Tab. 9: Direct connection

| Bowden cable or electro-hydraulic operation (E-control) | |
|---|---|
| Component | Required control devices on the tractor |
| Optional extra | Optional: <ul style="list-style-type: none"> • Double-acting control device or • single-acting control device and depressurised return line (max. back pressure in return line 5 bar) |

Tab. 10: Bowden cable or E-control

| Brake system | |
|---|--|
| Hydraulic working brake up to 6 km/h (not licensed for public road traffic) | <ul style="list-style-type: none"> • Single-acting control device |
| Dual-line compressed-air brake system | <ul style="list-style-type: none"> • Hose coupling (red) for the feed line • Hose coupling (yellow) for the brake line |
| Hydraulic service brake (only available for export) | <ul style="list-style-type: none"> • Hydraulic clutch according to ISO 5676 (100 bar) |

Tab. 11: Brake system

| Mirrors |
|--|
| The used tractor must be equipped with mirrors such that the hazardous areas on both sides of the machine are clearly visible from the tractor's seat. |

Tab. 12: Mirrors

6.4 Combination options of coupling devices and drawgears

The following table shows admissible combination options of the tractor's coupling device and the machine's drawgear depending on the maximum admissible tongue load.

- Only couple admissible combinations of tractor and hitched machine.

NOTE

The maximum admissible tongue load is indicated on the type plate of the coupling device, in the operating instructions and in the vehicle registration certificate of the tractor.

| Tractor's coupling device | Machine's drawgear |
|---|---|
| Bolt-type coupling DIN 11028 / ISO 6489-2 | <ul style="list-style-type: none"> • Drawbar lug 40 reinforced DIN 11026 / ISO 5692-2 • Drawbar lug 40 DIN 74054-1/2 / ISO 8755 |
| Non-automatic bolt-type coupling DIN 11025 | <ul style="list-style-type: none"> • Drawbar lug 40 DIN 74054-1/2 / ISO 8755 |
| Automatic bolt-type coupling 40 DIN 74051-1 / ISO 3584 | <ul style="list-style-type: none"> • Drawbar lug 40 DIN 74054-1/2 / ISO 8755 |
| Automatic bolt-type coupling 50 DIN 74052-1 / ISO 3584 | <ul style="list-style-type: none"> • Drawbar lug 50 DIN 74053-1 / ISO 1102 |
| Tow hook (hitch hook) ISO 6489-1 | <ul style="list-style-type: none"> • Drawbar lug (hitch ring) ISO 20019 • Drawbar lug (hitch ring) ISO 5692-1 |
| Draw pin (Piton-Fix) ISO 6489-4 | <ul style="list-style-type: none"> • Drawbar lug (hitch ring) ISO 5692-1 |
| Ball-type coupling 80 | <ul style="list-style-type: none"> • Shell 80 |

Tab. 13: Coupling devices and drawgears

6.5 D_C value and towing capacity

The D_C value is the theoretical thrust between tractor and rigid-drawbar trailer; it is a calculated reference value of forces between moving masses.

- Calculate the actual D_C value to check whether the coupling device of your tractor has the required D_C value.
- The calculated D_C value must be **equal or less than** (\leq) the specified D_C value of the tractor's coupling device and the drawgear of the rigid-drawbar trailer. In each case, the lowest D_C value shall be relevant.

If the calculated D_C value is higher, calculate the admissible tongue load for the tractor.

- Do not exceed the calculated towing capacity when filling the trailer.

WARNING

Risk of accident due to breaking components

An inadmissibly high load exerted on the coupling device and drawgear may cause failure of components and provoke dangerous situations for people.

- Only combine compatible coupling devices and drawgears.

6.5.1 Calculate Dc value

The actual Dc value can only be calculated from the gross vehicle weight rating of both quantities (tractor and trailer) as follows:

$$D_c \text{ (kN)} = g \cdot \frac{T \cdot C}{T+C}$$

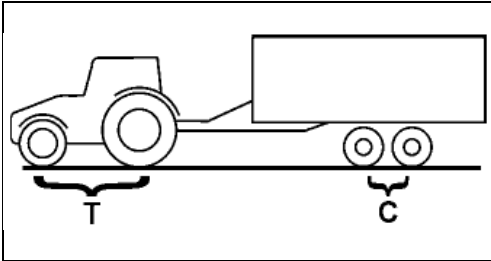

Fig. 39

- T Gross vehicle weight rating of tractor in [t]
(see operating instructions and vehicle registration certificate of tractor)
- C Axle load/sum of axle loads of the machine charged with the admissible mass (payload) in [t] without tongue load
- g Gravitational acceleration (9.81 m/s²)

Calculation example:

T = 14 t Gross vehicle weight rating of tractor in [t]

C = 18 t Admissible axle load(s) of rigid-drawbar trailer in [t]

$$D_c = 9,81 \text{ m/s}^2 \cdot \frac{14 \text{ t} \cdot 18 \text{ t}}{14 \text{ t} + 18 \text{ t}} = 77,2 \text{ kN}$$

NOTE

The Dc value for the coupling device is directly indicated on the type plate of the coupling device, in the operating instructions and in the vehicle registration certificate of the tractor.

In case of differing values on the type plates of the trailer bracket and the coupling device, the lower value shall be relevant.

The Dc value for the drawgear is directly indicated on the type plate of the drawgear.

6.5.2 Calculate towing capacity

The lowest D_C value of the tractor's coupling device or of the drawgear of the rigid-drawbar trailer determines the admissible towing capacity C of the tractor.

In case of rigid-drawbar trailers, the tractor's towing capacity is equal to the axle load(s) of the rigid-drawbar trailer.

The admissible towing capacity of the tractor determines the admissible load capacity of the rigid-drawbar trailer.

The towing capacity is calculated as follows:

$$C = \frac{T \cdot D_C}{g \cdot T - D_C}$$

- T Gross vehicle weight rating of tractor in [t]
(see operating instructions and vehicle registration certificate of tractor)
- D_C Lowest D_C value of the tractor's coupling device, of the drawgear of the rigid-drawbar trailer or of the combination
- g Gravitational acceleration (9.81 m/s²)

Calculation example:

- T = 14 t Gross vehicle weight rating of tractor in [t]
- D_C = 70 t D_C value of tractor's coupling device in [t]
- D_C = 77.5 t D_C value of drawgear at rigid-drawbar trailer in [t]
- D_C = 77.2 t D_C value for the combination to be coupled

$$C = \frac{14 \text{ t} \cdot 70 \text{ kN}}{9,81 \text{ m/s}^2 \cdot 14 \text{ t} - 70 \text{ kN}} = 14,5 \text{ t}$$

In this example, the admissible axle load is 14.5 t due to the D_C value of the tractor's coupling device.

Do not exceed the calculated towing capacity when charging the trailer.

6.6 Hitch and unhitch machine

6.6.1 Safety

As a basic principle, the following is applicable:

- Properly hitch the machine only to an appropriate tractor.
- Always check the machine for visible defects before hitching and unhitching.
- Do not exceed admissible limit values, ► see chapter 3, page 45.
- Secure tractor and machine against rolling before hitching or unhitching the machine.
- People are not allowed between tractor and machine, while the tractor is approaching the machine. Any helpers are only allowed to act as a guide next to the vehicles and to enter the space between the vehicles after the vehicles have stopped.
- Put the support device into support position when hitching and unhitching the machine. Keep limbs away from the area between support device and ground. Risk of crushing and shearing.
- Ensure sufficient tongue load at the support device when unhitching and parking a single-axle machine. Risk of tipping, particularly in case of unevenly charged machine.
- Properly use the provided coupling devices of the tractor and the machine.
- Take particular care when hitching and unhitching the machine. Crushing and shearing zones exist within the area of the coupling points between tractor and machine.
- Coupled supply lines must easily give way to any movements during cornering without any stress, buckling or chafing and must not chafe against external components.
- Always park the unhitched machine in a stable position. Observe the ground condition; beware of soft surfaces.

WARNING

Hitch the machine to the tractor

Improper hitching of the machine to the tractor may cause serious accidents.

- During hitching, observe all operating instructions:
 - of the tractor
 - of the machine
 - of the propeller shaft

6.6.2 Hitch machine

In the following, the procedure for hitching the machine is listed. The individual steps are described in detail in the respective subchapters and must be observed, see cross-references.

1. Secure machine against rolling.
 - ▶ see page 154
2. Couple drawbar.
 - ▶ see page 85
3. Couple forced steering axle (if available).
 - ▶ see page 79
4. Connect hydraulic hose pipes.
 - ▶ see page 101
5. Connect brake system.
 - Hydraulic working brake
 - ▶ see page 103
 - Compressed-air brake system
 - ▶ page 105
 - Hydraulic service brake
 - ▶ see page 108
6. Couple propeller shaft.
 - ▶ see page 93
7. Connect electrical supply lines and lighting system.
8. If available, insert the control set or the Bowden cable control set for the supporting leg into the holder of the tractor.
9. Lift supporting leg to transport position.
 - Mechanical supporting leg
 - ▶ see page 95
 - Hydraulic supporting leg
 - ▶ see page 97
10. Release parking brake.
 - ▶ see page 108

6.6.3 Unhitch machine

In the following, the procedure for unhitching the machine is listed. The individual steps are described in the respective subchapters and must be observed.

⚠ WARNING**Insufficient stability**

The machine may start to move. Risk of tilting.

- Park the empty machine on even and firm ground.
 - Secure machine against rolling.
-

NOTE

Ensure that there is always still enough free space in front of the machine when unhitching, such that the tractor can reapproach the machine in true alignment for hitching the machine again.

1. Lower supporting leg to support position.
 - Mechanical supporting leg
 - ▶ see page 96
 - Hydraulic supporting leg
 - ▶ see page 98
2. Secure machine against rolling.
 - ▶ see page 154
3. Disconnect electrical supply lines and lighting system.
4. Disconnect hydraulic hose pipes.
 - ▶ see page 101
5. Disconnect brake system.
 - Hydraulic working brake
 - ▶ see page 103
 - Compressed-air brake system
 - ▶ page 105
 - Hydraulic service brake
 - ▶ see page 108
6. Uncouple propeller shaft.
 - ▶ see page 94
7. If available, insert the control set or the Bowden cable control set for the supporting leg into the holder of the machine.
8. Uncouple forced steering axle (if available).
 - ▶ see section 6.7.3, page 82
9. Uncouple drawbar.
 - ▶ see page 88

6.7 Forced steering axle system

6.7.1 Safety

As a basic principle, the following is applicable:

- Observe the operating instructions of the axles.
- Only couple and uncouple the forced steering axle:
 - with the p.t.o. shaft switched off
 - with the tractor engine turned off
 - with the ignition key pulled out
 - with the parking brake applied.

Preconditions for safe operation of the forced steering axle system:

- Correct hydraulic oil level to ensure a sufficient supply of the steering axle(s) with hydraulic oil.
- Ball-type coupling K80 (according to ISO 24347) to couple the drawgear free of clearance and in a fail-safe manner.
- Ball-type coupling K50 (according to DIN 74058 / ISO 1103) at the same level and at a distance of 245-250 mm next to the K80 ball-type coupling to couple the forced steering axle free of clearance and in a fail-safe manner.

6.7.2 Couple forced steering axle

As a basic principle, the following is applicable:

- Properly hitch the machine only to an appropriate tractor.
- Do not exceed admissible limit values, chapter 3, page 45.
- Check whether the coupling device of the tractor is licensed for taking up the machine's drawgear.
- Properly hitch the machine to the tractor.
- Never use damaged or deformed trailer systems.
- People are not allowed between tractor and machine, while the tractor is approaching the machine. Any helpers are only allowed to act as a guide next to the vehicles and to enter the space between the vehicles after the vehicles have stopped.

WARNING

Uncontrolled machine movements

Risk of uncontrolled machine movements if the forced steering axle is not coupled to the tractor and the steering axles can move freely.

- Never move the machine with the forced steering axle uncoupled.
- Exclusively couple the forced steering axle to a ball-type coupling K50 (according to DIN 74058 / ISO 1103)!
When using couplings of other sizes, the ball socket may come loose during travelling.

1. Secure machine against rolling.
2. Prepare for hitching up:
 - Remove existing grease and dirt from the ball heads, holding-down devices, shell and coupling shells of the forced steering axle.
 - Lubricate the ball heads, the surfaces of the shell and the coupling shells with new grease.
 - Unlock the holding-down devices at the bearing blocks.
 - Swivel the holding-down devices to coupling position.
 - Clean and grease the ball heads.
3. **⚠ WARNING** – Risk of accident when approaching the machine. Keep people away from the hazardous area between tractor and machine. Reverse tractor and approach the machine, such that the ball head can take up the shell.
4. Align tractor and machine in a straight line.
5. Secure tractor against accidental starting and rolling.
6. Use the supporting leg to lower the drawbar until the ball head engages in the shell (1).
7. Lock and secure the holding-down device at the bearing block.
8. Connect the supply lines.
9. Lift the supporting leg to transport position.
10. Release the parking brake of the machine.
11. Couple the ball sockets (2) of the forced steering axle.
12. Lock and secure the holding-down devices at the two bearing blocks.

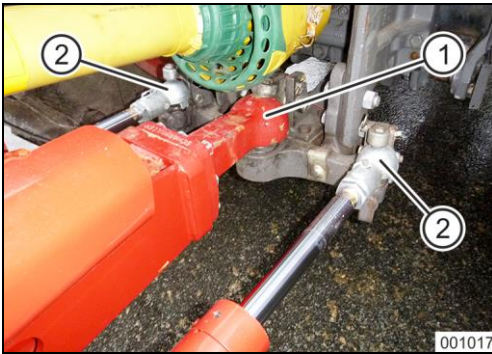

Fig. 40

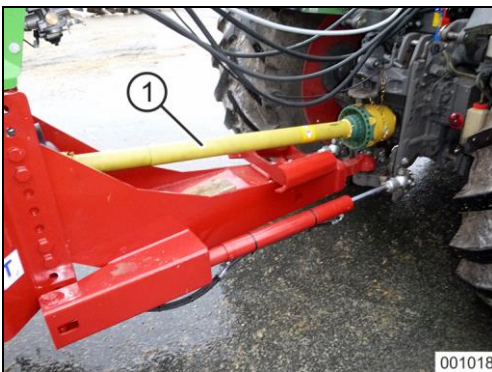

Fig. 41

13. Couple the propeller shaft (1).
 - ► see section 6.9.3, page 93
14. Connect the hydraulic system.
 - ► see section 6.12.2, page 101
15. Connect the brake system.
 - ► see page 105
 - ► see page 108

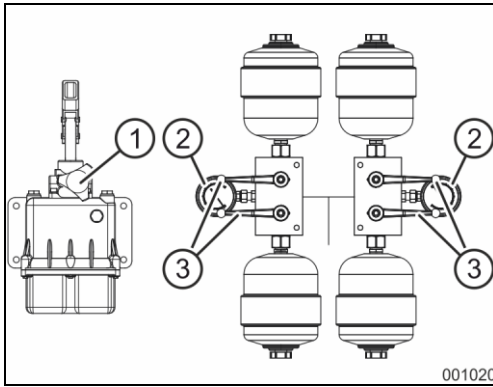

Fig. 42

16. Align machine.
 - Open all stop-cocks (3) of the pump.
 - Open the rotary wheel (1).
 - Make sure that tractor and machine are in a straight line.
 - Close the rotary wheel (1).
 - Preload the hydraulic system evenly to 70 – 80 bar, see pressure gauge (2). Preload each axle separately if necessary, close or open the respective stop-cocks (3) for this purpose.
 - Close all stop-cocks (3).
17. Switch the ignition of the tractor on.



Fig. 43

During initial commissioning:

18. Acquaint yourself with the maximum steering angle of your combination of tractor and machine before the first journey. Check any free space and possible steering angles for collision.
 - The ball socket (1) of the steering rod must not contact the drawbar (2), not even during maximum cornering to the left or right!
 - Adapt the bumper buffers to the tractor tyres if necessary. The position of the bumper buffers can be changed by means of the hole patterns.

6.7.3 Uncouple forced steering axle

⚠ WARNING

Insufficient stability

Insufficient stability of the unhitched machine may cause the machine to move. Risk of tilting.

- Park the empty machine in horizontal position on firm ground.
- Secure machine against rolling.

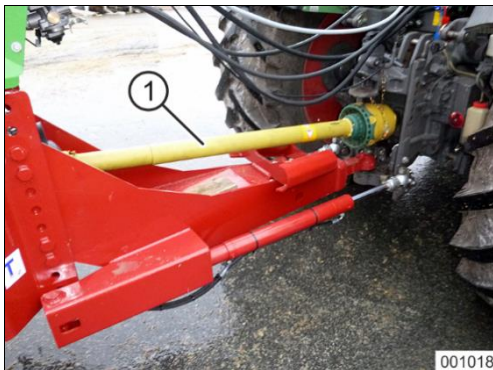

Fig. 44

1. Align tractor and machine in a straight line.
2. Secure tractor against accidental starting and rolling.
3. Disconnect brake system.
 - ▶ see page 106
 - ▶ see page 101
4. Disconnect the hydraulic system.
 - ▶ see section 6.9.4, page 94
5. Uncouple the propeller shaft (1).
 - ▶ see page 108



Fig. 45

6. Unlock the holding-down devices at the two bearing blocks.

NOTE

If the master cylinders are warped and the ball sockets cannot be loosened, open the rotary wheel and the stop-cock to depressurise the system.

7. Swivel the holding-down device to coupling position.
8. Uncouple the ball sockets (2) of the forced steering axle.
9. Unlock the holding-down device at the bearing block for the shell.
10. Swivel the holding-down device to coupling position.
11. Lower the supporting leg to support position, such that the shell (1) disengages from the ball head.
12. Release the parking brake of the machine.
13. Move the tractor forward (approx. 25 cm).
14. Secure tractor and machine against accidental starting and rolling
15. Lock and secure the holding-down devices at the bearing blocks.
16. Move the tractor forward.

6.8 Drawbar

6.8.1 Adapt mounting height of drawbar

Adapt the mounting height of the drawbar to the respective tractor model if the machine hitched to the tractor is not horizontally aligned on even ground.

The mixing auger only works at its optimum in horizontally aligned position.

NOTE

When horizontally aligning the machine, use the top edge of the mixing container for guidance.

WARNING

Sinking chassis

Risk of crushing due to accidental sinking of chassis during work on the drawbar.

- Ensure sufficient ground stability.
 - Use additional solid, load-distributing supports if necessary.
-

This work requires expert knowledge and appropriate tools.

Operative staff:

- Qualified staff or
 - authorised workshop
-

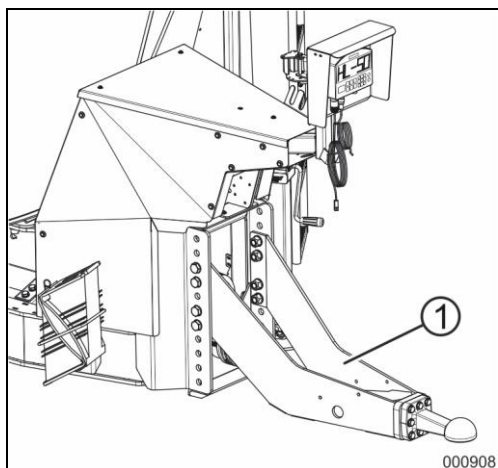

Fig. 46

1. Park the machine in horizontal position on firm ground.
2. Switch the machine off.
3. Use the chocks to secure the machine against accidental rolling.
4. Unhitch the machine from the tractor.
5. Move the tractor forward until the coupling device of the tractor uncovers the drawgear of the drawbar.
6. Align the machine in horizontal position by means of the supporting leg.
 - The top edge of the mixing container must be in parallel to the ground.
7. Align the coupling device on the tractor such that the coupling device can take up the drawgear of the drawbar.
8. Have the mounting height of the drawbar (1) adapted by an authorised workshop if the adjusting range for the coupling device on the tractor is not sufficient to hitch the machine in horizontal position.
9. Check the free space around the propeller shaft.
 - There must be sufficient free space in any operating state to avoid damage to the propeller shaft.

6.8.2 Couple drawbar

As a basic principle, the following is applicable:

- Properly hitch the machine only to an appropriate tractor.
- Do not exceed admissible limit values, chapter 3, page 45.
- Check whether the coupling device of the tractor is licensed for taking up the machine's drawgear.
- Properly hitch the machine to the tractor.
- Never use damaged or deformed trailer systems.
- People are not allowed between tractor and machine, while the tractor is approaching the machine. Any helpers are only allowed to act as a guide next to the vehicles and to enter the space between the vehicles after the vehicles have stopped.

Bolt-type coupling

1. Secure machine against rolling.
2. Prepare for hitching up:
 - Remove the coupling bolt (non-automatic bolt-type coupling)
 - Open the hitch, i.e. it must be prepared for coupling (automatic bolt-type coupling)
3. **⚠ WARNING** – Risk of accident when approaching the machine. Keep people away from the hazardous area between tractor and machine. Reverse tractor and approach the machine, such that tractor and machine can be coupled by means of the coupling bolt (non-automatic bolt-type coupling).
 - until the bolt-type coupling engages in the drawbar lug (automatic bolt-type coupling).
4. Secure tractor against accidental starting and rolling.
5. Check that the connection is secure after coupling:
 - Secure the inserted coupling bolt by positive locking (non-automatic bolt-type coupling)
 - Check whether the automatic bolt-type coupling is locked (control pin, end position of operating lever, etc.)
6. Connect the supply lines.
7. Lift the supporting leg to transport position.
8. Release the parking brake of the machine.

Tow hook (hitch hook) and drawbar lug (hitch ring)

1. Secure machine against rolling.
2. Lower tow hook.
3. **▲ WARNING** – Risk of accident when approaching the machine. Keep people away from the hazardous area between tractor and machine. Reverse tractor and approach the machine,
 - such that the lowered tow hook can take up the drawbar lug.
4. Lift the tow hook to catch the drawbar lug.
 - The drawbar lug automatically engages and is fixed between the tow hook and the locking mechanism (holding-down device).
5. Secure tractor against accidental starting and rolling.
6. Ensure that the tow hook is properly locked.
7. Connect the supply lines.
8. Lift the supporting leg to transport position.
9. Release the parking brake of the machine.

Draw pin (Piton-Fix) and drawbar lug (hitch ring)

1. Secure machine against rolling.
2. **▲ WARNING** – Risk of accident when approaching the machine. Keep people away from the hazardous area between tractor and machine. Reverse tractor and approach the machine.
3. Secure tractor against accidental starting and rolling.
4. Remove the holding-down device (cross bolt) above the draw pin.
5. Connect the supply lines.
6. Drive as close as possible towards the machine, such that the draw pin can take up the drawbar lug.
7. Lower the drawbar by means of the supporting leg until the draw pin engages in the drawbar lug.
8. Secure tractor against accidental starting and rolling.
9. Fix and secure the cross bolt above the draw pin.
10. Lift the supporting leg to transport position.
11. Release the parking brake of the machine.

Ball-type coupling and shell

⚠ WARNING

Unhitch the machine from the tractor

When travelling on particularly uneven ground or over clamp silos, the shell might loosen from the ball-type coupling. Risk of dangerous situations to people due to unintentional unhitching of the machine.

- Check the free space between holding-down device and shell.
- Mount shorter holding-down device if necessary.

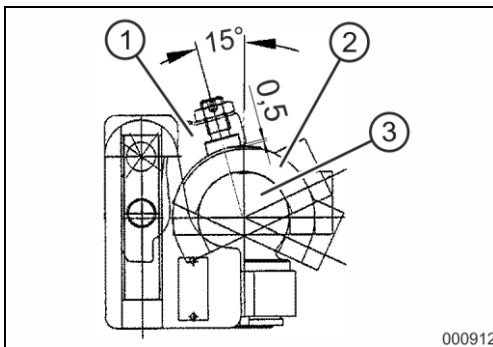

Fig. 47

If the free space between holding-down device (1) and shell (2) is not sufficient, mount a shorter holding-down device on the tractor's ball-type coupling (3).

NOTE

Lubricate the coupling device every day to minimise wear on the ball head and the shell. Lubricate the area between the holding-down device and the surface of the shell as well.

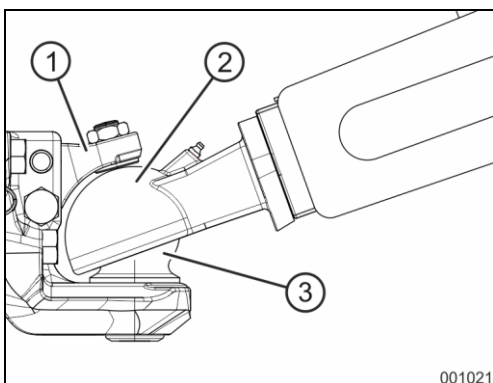

Fig. 48

1. Secure machine against rolling.
2. Prepare for hitching up:
 - Remove grease and dirt from the holding-down device (1), the shell (2) and the ball head (3).
 - Lubricate the ball head and the surface of the shell with new grease.
 - Unlock the holding-down device (1) at the bearing block.
 - Swivel the holding-down device to coupling position.
 - Clean and grease the ball head.
3. **⚠ WARNING** – Risk of accident when approaching the machine. Keep people away from the hazardous area between tractor and machine. Reverse tractor and approach the machine, such that the ball head can take up the shell.
4. Secure tractor against accidental starting and rolling.
5. Lower the drawbar by means of the supporting leg until the ball head (3) engages in the shell (2).
6. Lock and secure the holding-down device at the bearing block.
7. Connect the supply lines.
8. Lift the supporting leg to transport position.
9. Release the parking brake of the machine.

6.8.3 Uncouple drawbar

WARNING

Insufficient stability

Insufficient stability of the unhitched machine may cause the machine to move. Risk of tilting.

- Park the empty machine in horizontal position on firm ground.
- Secure machine against rolling.

Bolt-type coupling

1. Secure tractor against accidental starting and rolling.
2. Secure machine against rolling.
3. Lower the supporting leg to support position, such that the drawbar no longer transmits any tongue load to the tractor.
4. Disconnect the supply lines.
5. Place the supply lines into the plug deposit.
6. Prepare for unhitching:
 - Remove the coupling bolt (non-automatic bolt-type coupling)
 - Open the trailer hitch (automatic bolt-type coupling).
7. Move the tractor forward.

Tow hook (hitch hook) and drawbar lug (hitch ring)

1. Secure tractor against accidental starting and rolling.
2. Secure machine against rolling.
3. Lower the supporting leg to support position.
4. Lower the tow hook.
5. Move the tractor forward (approx. 25 cm).
6. Lift the tow hook.
7. Secure tractor against accidental starting and rolling.
8. Disconnect the supply lines.
9. Place the supply lines into the plug deposit.
10. Move the tractor forward.

Draw pin (Piton-Fix) and drawbar lug (hitch ring)

1. Secure tractor against accidental starting and rolling.
2. Secure machine against rolling.
3. Remove the holding-down device (cross bolt) above the draw pin.
4. Lower the supporting leg to support position.
5. Move the tractor forward (approx. 25 cm).
6. Secure tractor against accidental starting and rolling.
7. Fix and secure the holding-down device (cross bolt) above the draw pin.
8. Disconnect the supply lines.
9. Place the supply lines into the plug deposit.
10. Move the tractor forward.

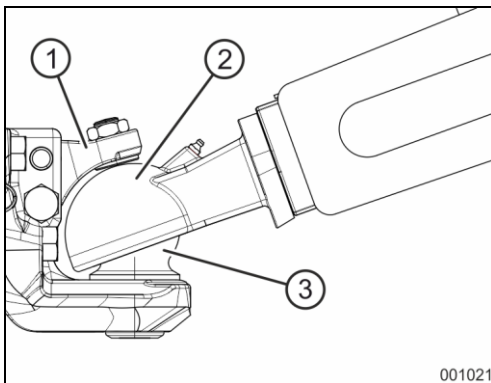

Fig. 49

Ball-type coupling and shell

1. Unlock the holding-down device (1) at the bearing block.
2. Swivel the holding-down device to coupling position.
3. Lower the supporting leg to support position, such that the shell (2) disengages from the ball head (3).
4. Move the tractor forward (approx. 25 cm).
5. Secure tractor and machine against accidental starting and rolling
6. Lock and secure the holding-down device at the bearing block.
7. Disconnect the supply lines.
8. Place the supply lines into the plug deposit.
9. Move the tractor forward.

6.9 Propeller shaft

The power transmission between tractor and machine is effected by means of the propeller shaft.

6.9.1 Safety

As a basic principle, the following is applicable:

- Observe the operating instructions for the propeller shaft.
- A protective device in proper condition must each be mounted at the p.t.o. shaft of the tractor and of the machine.
- The protective devices on the tractor and on the machine and the protective devices of the extended propeller shaft overlap by at least 50 mm. If not, the machine must not be powered via the propeller shaft.
- Never use the propeller shaft without protective device or with a damaged protective device or without proper handling of the clip chain.
- There must be sufficient free space around the propeller shaft in any operating state to avoid damage to the propeller shaft.
- Mounting and dismounting of the propeller shaft is only allowed:
 - with the p.t.o. shaft switched off
 - with the tractor engine turned off
 - with the ignition key pulled out
 - with the parking brake applied.
- Never switch the propeller shaft on with the tractor engine turned off.
- Slip the protective element onto the p.t.o. shaft stub after removal of the propeller shaft.

6.9.2 Adapt length of propeller shaft

Only an authorised workshop is allowed to carry out structural alterations on the propeller shaft. Observe the enclosed operating instructions for the propeller shaft.

- Structural alterations on the propeller shaft which are not specified in the enclosed operating instructions for the propeller shaft are not allowed.
- Take a sufficient transverse contact ratio into account when adapting the propeller shaft length.
- Have the length of the propeller shaft checked in all operating states by an authorised workshop before coupling the propeller shaft to the tractor for the first time.
- Adapt the length if necessary to prevent a compression or insufficient transverse contact ratio.
- The adjustment of the propeller shaft only applies to the current tractor model. Readaptation of the propeller shaft may be necessary if hitching the machine to another tractor.

NOTE

The propeller shaft reaches its shortest operating position during extreme cornering. The propeller shaft reaches its longest operating position during straight travelling.

- Observe possible changes in inclination between tractor and machine, e.g. in case of ramp travel.
- Observe specific differences between top and bottom linkage.

WARNING

Rolling of tractor and machine

Risk of crushing if tractor and machine accidentally roll.

- Secure tractor and machine against accidental starting and rolling before entering the hazardous area between the tractor and the hitched machine.

This work requires expert knowledge and appropriate tools.

Operative staff:

- Authorised workshop

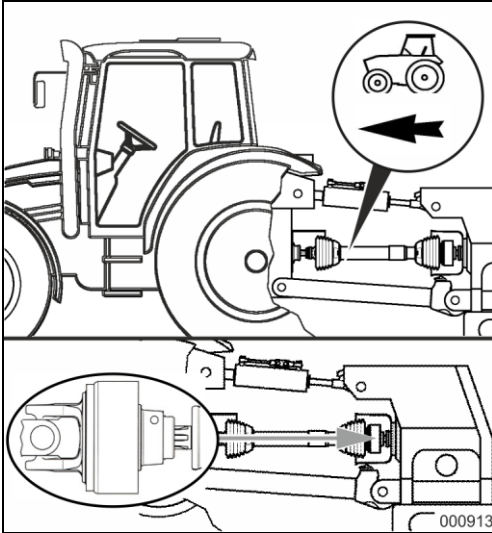

Fig. 50

1. Park the machine in horizontal position on firm ground.
2. Use the chocks to secure the machine against accidental rolling.
3. Hitch the machine to the tractor.
 - Do not couple the propeller shaft.
4. Take the shortest operating position of the propeller shaft.
5. Secure tractor and machine against accidental starting and rolling before entering the hazardous area between tractor and machine.
6. Pull the propeller shaft apart.
7. Slip the fork of the propeller shaft half with the tractor symbol onto the p.t.o. shaft of the tractor until the locking mechanism noticeably engages.
8. Slip the fork of the other propeller shaft half onto the p.t.o. shaft of the machine until the locking mechanism noticeably engages.
9. Determine the length and shorten the propeller shaft.
 - See enclosed operating instructions for the propeller shaft.
10. Reinsert the shortened propeller shaft halves into each other.
11. Lubricate the p.t.o shaft of the tractor and the machine's p.t.o. shaft before coupling the propeller shaft.

6.9.3 Couple propeller shaft to tractor

When coupling the propeller shaft, observe:

- Admissible driving speed of the machine
- Correct driving direction of the propeller shaft
- Proper fitting length of the propeller shaft
- Proper mounting position of the propeller shaft. The tractor symbol on the protective tube of the propeller shaft indicates the propeller shaft connection at the tractor.

⚠ WARNING

Risk of becoming entangled by powered propeller shaft

The powered propeller shaft may catch clothing and draw it in and fling away foreign objects.

- Check the safety and protective devices of the propeller shaft for proper functioning before each start-up of the machine.
- Immediately turn the tractor engine off in case of emergency.



Fig. 51

1. Clean and lubricate the p.t.o. shaft stub on the tractor.
2. Start the tractor engine.
3. Hitch the machine to the tractor.
4. Turn the engine off.
5. Secure tractor against accidental starting and rolling.
6. Make sure that the p.t.o. shaft has been switched off.
7. Release the p.t.o. shaft brake on the tractor if necessary.
8. Slip the propeller shaft onto the p.t.o. shaft stub until the locking mechanism noticeably engages.
9. Secure the propeller shaft guard at the tractor and at the machine against rotating by means of the clip chains (1).
 - Fix the clip chains at right angles to the propeller shaft if possible.
 - Fix the clip chains such that a sufficient swivelling range of the propeller shaft is ensured in any operating state.
 - Clip chains must not get entangled in tractor or machine components.
10. Check the free space around the propeller shaft.
 - There must be sufficient free space in any operating state to avoid damage to the propeller shaft.

6.9.4 Uncouple propeller shaft from tractor

⚠ CAUTION**Burns due to hot components**

Risk of burns due to hot components of the propeller shaft.

- Do not touch considerably warmed-up propeller shaft components, particularly do not touch any couplings.



Fig. 52

1. Secure tractor and machine against accidental starting and rolling
2. Remove the clip chain from the tractor.
3. Unlock the locking mechanism.
4. Strip the fork of the propeller shaft off the p.t.o. shaft of the tractor.
5. Place the propeller shaft onto the respective holder (1).

NOTE

Clean and lubricate the propeller shaft before longer downtimes.

6.10 Supporting leg

The unhitched machine rests on the supporting leg. Depending on the machine's equipment, it is fitted with:

- a mechanical supporting leg
- a hydraulic supporting leg
- bottom hitch with fixed supporting leg

6.10.1 Mechanical supporting leg

Use the crank handle (1) to lift or lower the mechanical supporting leg with spindle adjustment and telescopic quick adjustment (3).

- Turn clockwise; the supporting leg is lifted to transport position
- Turn counterclockwise; the supporting leg is lowered to support position

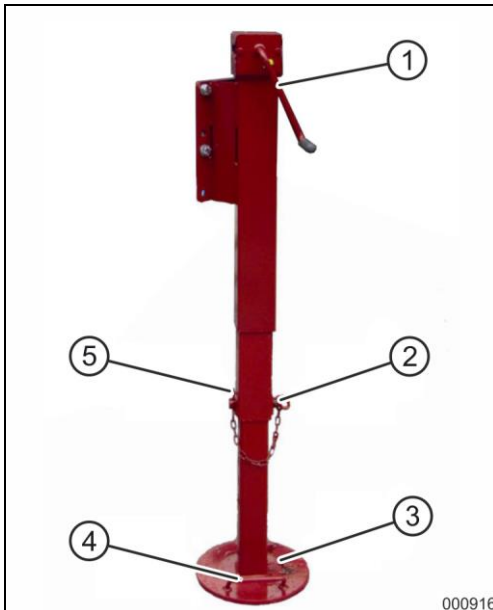

Fig. 53

Anheben in Transportstellung

1. Hitch the machine to the tractor.
2. Secure tractor and machine against accidental starting and rolling
3. Relieve the supporting leg via the crank handle (1).
 - Turn crank handle clockwise.
4. Use one hand to grip the handle (4) of the telescopic quick adjustment (3).
5. Use the other hand to unlock and remove the locking bolt (2).
6. Lift the telescopic quick adjustment of the supporting leg as far as it will go.
7. Secure the supporting leg in the lifted transport position by means of the locking bolt.
8. Secure the locking bolt against accidental losing by means of the spring cotter (5).

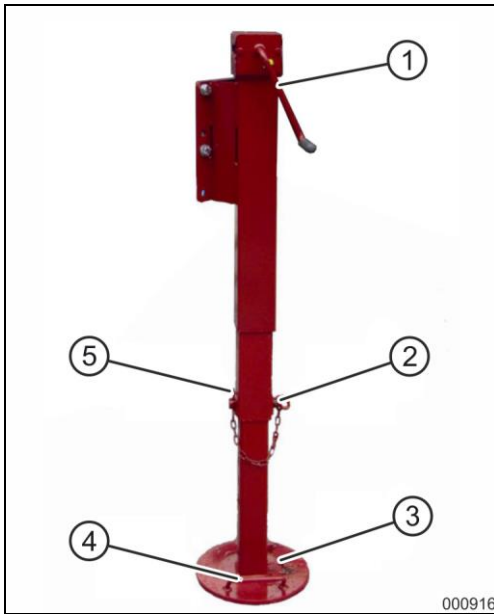

Fig. 54

Absenken in Stützstellung

1. Secure tractor and machine against accidental starting and rolling
2. Use one hand to grip the handle (4) of the telescopic quick adjustment (3).
3. Use the other hand to unlock and remove the locking bolt (2).
4. Lower the telescopic quick adjustment of the supporting leg to a position just above the ground.
5. Secure the supporting leg in the lowered position by means of the locking bolt.
6. Secure the locking bolt against accidental losing by means of the spring cotter (5).
7. Use the crank handle (1) to lower the supporting leg to support position.
 - Turn crank handle counterclockwise.

6.10.2 Hydraulic supporting leg

Optional extra

Depending on the machine's equipment, the supporting leg is operated by remote control from the tractor

- directly via a double-acting control device of the tractor (standard equipment).
- via Bowden cable operation (optional extra).
- via the control set (electro-hydraulic operation, optional extra).

⚠ WARNING

Risk of crushing due to hydraulic supporting leg

Risk of crushing of fingers, hands and feet due to movements of the supporting leg

- Keep an adequate safety distance from the supporting leg as long as parts are moving.
- Keep people away from the hazardous area before actuating the hydraulic supporting leg.



Fig. 55

Anheben in Transportstellung

1. Keep people away from the hazardous area between tractor and machine before lifting the supporting leg.
2. Open the stop-cock (1) to lift the supporting leg.
3. Keep hold of the respective operating element in "Lifting" position until the supporting leg has been lifted from its support position to its transport position.
4. Close the stop-cock (1) to secure the supporting leg in its transport position.

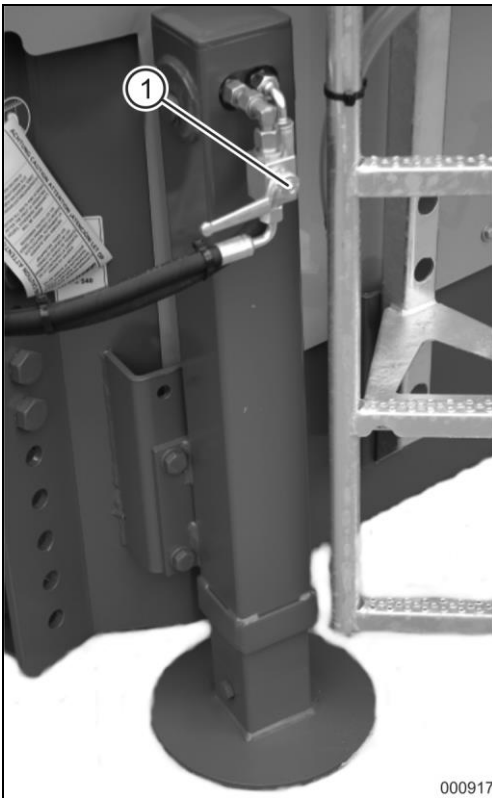

Fig. 56

Absenken in Stützstellung

1. Keep people away from the hazardous area between tractor and machine before lowering the supporting leg.
2. Open the stop-cock (1) to lower the supporting leg.
3. Keep hold of the respective operating element in "Lowering" position until the supporting leg has been lowered from its transport position to its support position.
→ The drawbar no longer transmits any tongue load to the tractor.
4. Close the stop-cock (1) to prevent a lowering of the supporting leg.

6.10.3 Fixed supporting leg with bottom hitch

Optional extra

The machine is put down resting on a fixed supporting leg of the bottom hitch. Lifting and lowering is executed via the hitch hook of the tractor.



Fig. 57

6.11 Check machine for proper functioning

Check the machine for proper functioning before the first start-up and each time before starting work.

1. Hitch the machine to the tractor.
2. Completely lubricate the machine and the propeller shaft, ► see section 0, page 174.
3. Check the oil level of the angular gear in the compensating reservoir, ► see section 10.10.1, page 182.
4. Check all functions of the machine before filling the mixing container for the first time.
 - Open and close dosage gate.
 - Check brake system function.

If available:

- Lower the hydraulic supporting leg to support position and lift it to transport position.
- Extend and retract the hydraulic counter-cutters into and from the mixing container.
- Let the crossover conveyor run in both driving directions.
- Let the crossover conveyor run at different conveyor speeds.
- Lower the conveyor extension to working position and lift it to transport position.
- Lower the discharge conveyor for side discharge to working position and lift it to transport position.
- Let the discharge conveyor for side discharge run in driving direction (in working position).
- Let the discharge conveyor for side discharge run at different conveyor speeds (in working position).
- Check the weighing device for proper functioning.
- Check the lighting system for proper functioning.

6.12 Hydraulic hose pipes

6.12.1 Safety

As a basic principle, the following is applicable:

- Improperly connected hydraulic hose pipes may cause malfunctions of the hydraulic system. Check the assignment of the hydraulic hose pipes at the control block of the machine if the coloured markings (dust caps) are missing:
 - P = Pressure line
 - T (R;S) = Return line
- Check the compatibility of the hydraulic oils before connecting the machine to the hydraulic system of the tractor.
- Never mix different types of hydraulic oil.
- Observe the maximum admissible operating pressure of the hydraulic oil.
- Only connect clean hydraulic plugs and sleeves.
- Insert the hydraulic plug into the hydraulic sleeve until the hydraulic plug noticeably locks.
- Check the coupling spots of the hydraulic hose pipes for correct and tight seat.
- Connected hydraulic hose pipes must easily give way to any movements during cornering without any stress, buckling or chafing and must not chafe against external components.

WARNING

Risk of infection due to hydraulic oil squirting out

Hydraulic oil squirting out under high pressure may penetrate the skin and enter the body, potentially causing serious injuries. Risk of serious infection.

- Depressurise the hydraulic system of the tractor and the machine before connecting and disconnecting the hydraulic hose pipes.
- Always swivel the operating element at the control device on the tractor to floating position.

6.12.2 Hydraulikschlauchleitungen ankuppeln

1. Always swivel the respective operating elements at the control device on the tractor to floating position.
2. Connect the hydraulic hose pipes to the tractor's control devices:
 - Pressure line to a single-acting or double-acting control device.
 - Return line to a depressurised return port if possible.

6.12.3 Hydraulikschlauchleitungen abkuppeln

⚠ CAUTION

Burns due to hot components

Risk of burns due to hot components of the hydraulic hose pipes

- Do not touch considerably warmed-up components of the hydraulic hose pipes, particularly do not touch any hydraulic plugs and sleeves.

1. Always swivel the respective operating elements at the control device on the tractor to floating position.
2. Switch the tractor engine off.
3. Disconnect hydraulic hose pipes.
4. Use the dust caps to protect the hydraulic plugs against soiling.
5. Place hydraulic hose pipes into the plug deposit.

6.13 Brake system

NOTE

The braking axle needs to run in during the first service hours, such that the brake lining adjusts to the brake drum. Full braking power is only reached after this running-in period.

- Check the brake system for proper functioning before carrying out a transport journey.

6.13.1 Hydraulic working brake

NOTE

A machine equipped with a hydraulic working brake is a pure yard vehicle and not licensed for use on public roads. The maximum admissible speed is 6 km/h.

We explicitly point out the risk of losing insurance coverage if you cause an accident while exceeding the admissible maximum speed of 6 km/h.

When connecting the hydraulic working brake to the tractor, ensure that the full system pressure always acts on the brake connection, even when switching on other hydraulic functions.



Fig. 58

- 1 Hydraulic plug ISO 7241-A DIN 2353

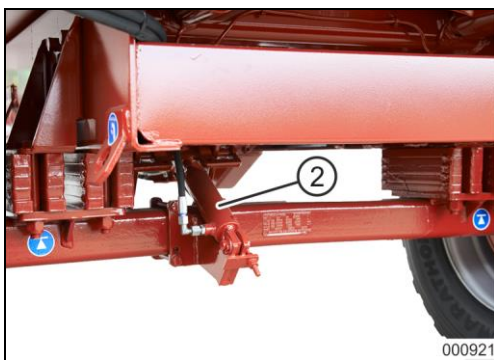

Fig. 59

- 2 Hydraulic cylinder of braking axle

Bremsanlage ankuppeln

As a basic principle, the following is applicable:

- Only connect clean hydraulic plugs and sleeves.
 - Insert the hydraulic plug into the hydraulic sleeve until the hydraulic plug noticeably locks.
 - Check the coupling spots of the hydraulic hose pipes for correct and tight seat.
 - Connected hydraulic hose pipes must easily give way to any movements during cornering without any stress, buckling or chafing and must not chafe against external components.
 - Check the brake system for proper functioning before carrying out a transport journey.
1. Always swivel the operating element at the control device on the tractor to floating position.
 2. Remove the dust cap from the hydraulic plug.
 3. Connect the hydraulic plug with the hydraulic sleeve to a single-acting or a double-acting control device of the tractor.
 - Only connect to a control device with floating position.
 4. Release the parking brake.

Bremsanlage abkuppeln

1. Apply the parking brake.
2. Relieve the brake hydraulics.
 - Swivel the operating element to floating position, such that the hydraulic oil flows back to the tractor.
3. Disconnect the hydraulic plug.
4. Use the dust cap to protect the hydraulic plug against soiling.
5. Place the hydraulic brake line into the plug deposit.

6.13.2 Compressed-air brake system

Set braking force

The brake pressure regulator can be used to manually adapt the braking effect (braking force) of the brake system to the current loading condition of the machine. The following positions are possible:

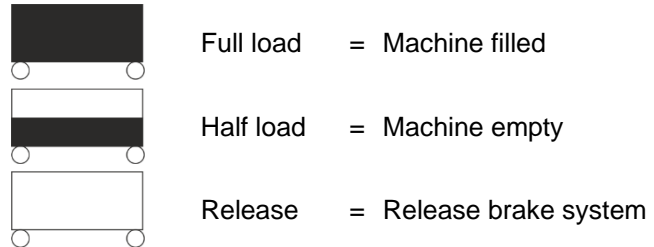

The "Release" position allows to manoeuvre the machine with the brake hoses not coupled to the manoeuvring vehicle.

Due to the vehicle weight, the brake pressure regulator must be set to half load when the machine is empty.

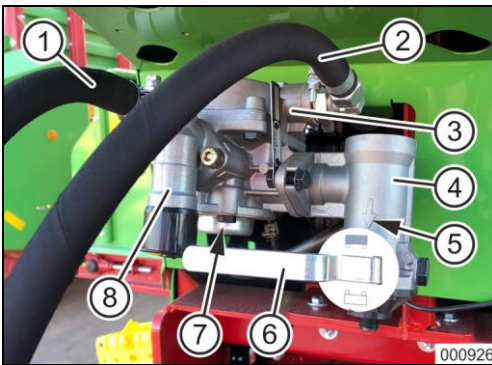

Fig. 60

- 1 Feed line with hose coupling (red)
- 2 Brake line with hose coupling (yellow)
- 3 In-line filter of brake line
- 4 Brake pressure regulator
- 5 Reading point of set braking effect
- 6 Hand lever for adapting braking effect
- 7 Trailer brake valve
- 8 In-line filter of feed line

Example – Machine filled: Turn hand lever (6) such that the "Full load" symbol is beneath the reading point (5).

NOTE

It is imperative to adapt the braking effect of the brake system to the current loading condition of the machine by means of the brake pressure regulator before carrying out a transport journey.

Only with the braking effect adapted

- is the pressure released by the trailer brake valve limited.
- are there no jolting impacts.
- is the combination of tractor and machine sensitively and gradually slowed down.
- does the combination of tractor and machine remain in straight position due to advanced braking.

Brems- und Vorratsleitung ankuppeln

As a basic principle, the following is applicable:

- When connecting the brake and feed line, ensure that
 - the sealing rings of the hose couplings are clean.
 - the sealing rings of the hose couplings seal tightly.
- Immediately replace damaged sealing rings.
- Drain the air reservoir every day before the first trip.
- Only start the tractor with the hitched machine moving when the pressure gauge of the brake system on the tractor indicates 5.0 bar.
- Check the course of the connected brake lines. The brake lines must not chafe against external components.

WARNING

Rolling of machine

Risk of dangerous situations to people caused by the machine rolling due to released brake system.

- Always connect the hose coupling of the brake line (yellow) first and then the hose coupling of the feed line (red).

The machine's brake system immediately leaves the brake position if the red hose coupling is connected.



Fig. 61

1. Open the caps of the hose couplings on the tractor.
2. Remove the hose coupling of the brake line (yellow) (2) from the blank connection.
3. Clean soiled sealing rings or replace damaged sealing rings.
4. Properly fix the hose coupling of the brake line (yellow) (2) to the yellow marked coupling device at the tractor.
5. Remove the hose coupling of the feed line (red) (1) from the blank connection.
6. Clean soiled sealing rings or replace damaged sealing rings.
7. Properly fix the hose coupling of the feed line (red) (1) to the red marked coupling device at the tractor.
8. Adapt the braking effect of the service brake system to the current loading condition of the machine by means of the brake pressure regulator.
9. Release the parking brake of the machine and/or remove the chocks.

Brems- und Vorratsleitung abkuppeln

WARNING

Rolling of machine

Risk of dangerous situations to people caused by the machine rolling due to released brake system.

- Always disconnect the hose coupling of the feed line (red) first and then the hose coupling of the brake line (yellow).

The machine's brake system only moves to brake position if the red hose coupling is disconnected.

It is imperative to observe this order, as otherwise the brake system will be released and the non-braked machine may start to move.

NOTE

When the machine is unhitched or torn off, the feed line connected to the trailer brake valve bleeds. The trailer brake valve automatically switches over, thus actuating the brake according to the set braking effect.



Fig. 62

1. Secure machine against rolling.
2. Disconnect the hose coupling of the feed line (red) (1).
3. Disconnect the hose coupling of the brake line (yellow) (2).
4. Fix the hose couplings to the blank connections.
5. Close the caps of the hose couplings at the tractor.

Manoeuvre unhitched machine by means of a manoeuvring vehicle

WARNING

Rolling of machine

Risk of dangerous situations to people caused by the machine rolling due to released brake system.

- Tightly connect the machine with the braked manoeuvring vehicle before releasing the brake by means of the hand lever at the brake pressure regulator. The machine is now exclusively decelerated by the manoeuvring vehicle.



Fig. 63

1. Hitch the machine to the braked manoeuvring vehicle.
2. Release the parking brake of the machine.
3. Swivel the hand lever (1) at the brake pressure regulator to "Release" position.
 - The service brake is released and the machine can be manoeuvred.
4. Move the machine by the manoeuvring vehicle.
5. Apply the parking brake of the manoeuvring vehicle after completion of manoeuvring.
6. Swivel the hand lever at the brake pressure regulator back to its initial position after manoeuvring.
 - The system pressure from the air reservoir slows the machine down.
7. Apply the parking brake of the machine.
8. Unhitch the machine from the manoeuvring vehicle.

6.13.3 Hydraulic service brake

Hydraulische Betriebsbremse ankuppeln

As a basic principle, the following is applicable:

- Only connect clean hydraulic clutches.
- Clean hydraulic plug and hydraulic sleeve if necessary.
- Insert the hydraulic plug into the hydraulic sleeve until the hydraulic plug noticeably locks.
- Check the coupling spot of the hydraulic brake line for correct and tight seat.
- The connected brake line must easily give way to any movements during cornering without any stress, buckling or chafing and must not chafe against external components.
- Check the hydraulic brake system for proper functioning before carrying out a transport journey.

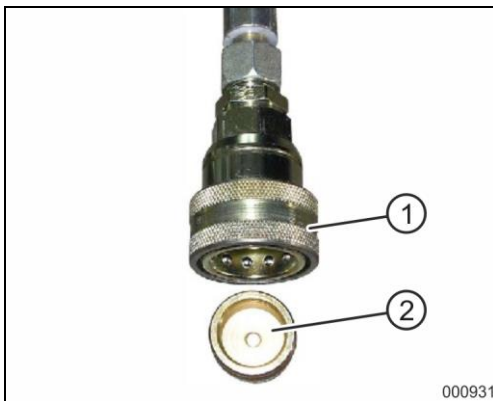

Fig. 64

1. Remove the hydraulic sleeve (1) from the machine's blanked-off connecting piece (2).
2. Couple the machine's hydraulic sleeve to the tractor's hydraulic plug of the hydraulic brake system.
3. Release the parking brake of the machine.

Hydraulische Betriebsbremse abkuppeln

1. Apply the parking brake of the machine.
2. Uncouple the hydraulic sleeve (1).
3. Slip the hydraulic sleeve onto the machine's blanked-off connecting piece (2).

6.13.4 Parking brake

Feststellbremse lösen

ATTENTION

Chafing points

- Ensure that the cable does not rest on or chafe against other vehicle components.
- The cable must sag slightly when the parking brake is released.

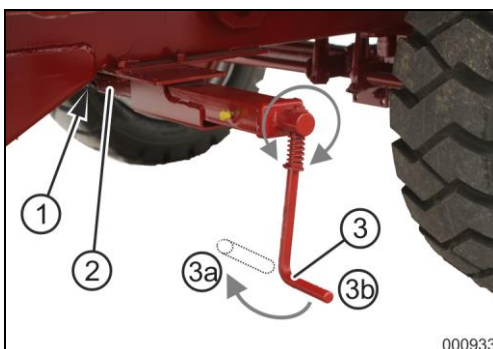

1. Swivel the crank handle (3) from its rest position (3a) by 180° into its adjustment position (3b).
2. Turn the crank handle counterclockwise until the cable (1) is relieved.
→ The parking brake has been released.
3. Swivel the crank handle to its rest position.

Apply parking brake

Fig. 65

NOTE

Correct the setting of the parking brake if the tension path of the spindle (2) is no longer sufficient.

1. Swivel the crank handle (3) from its rest position (3a) by 180° into its adjustment position (3b).
 2. Turn crank handle clockwise.
- The parking brake is applied via the cable (1).

6.14 Container extension

6.14.1 Safety

- Only authorised and qualified staff is allowed to mount the container extension.
- The manufacturer will not assume any warranty and liability for material damage and personal injuries if the work is carried out by insufficiently qualified staff.
- Exclusively use original spare parts or parts approved by the manufacturer.
- Observe the maximum extension height; the container extension increases the vehicle height. See chapter "Technical data".
- Combining different extensions is not allowed.

ATTENTION

Damage to the machine due to overload

If the mixing container is excessively filled due to a non-approved extension, the machine may be overloaded due to too much mass in the mixing container.

- Exclusively use approved extensions.

Optional extra

The container extension (1) increases the mixing capacity and additionally prevents the fodder from being thrown over the container edge. However, do not fill the mixing container completely up to the newly gained capacity.

The container extension (1) is screwed to the container edge (3). The overflow ring (2) is mounted at the top edge of the container extension.



Fig. 66

6.15 Set conveyor speed

Optional extra

The conveyor speed of the conveyor belts is infinitely adjustable.

The set conveyor speed determines the lateral delivery distance (throwing range) of the fodder next to the machine. An increasing conveyor speed results in a larger lateral delivery distance of the fodder.

The conveyor speed is infinitely adjusted at the flow regulation valve

- manually directly at the machine or
- by remote control via the control set from the tractor.

NOTE

The set scale value is not an absolute value for the conveyor speed, but only a reference value. Depending on the tractor model, the set conveyor speed may differ even if the scale value is identical.

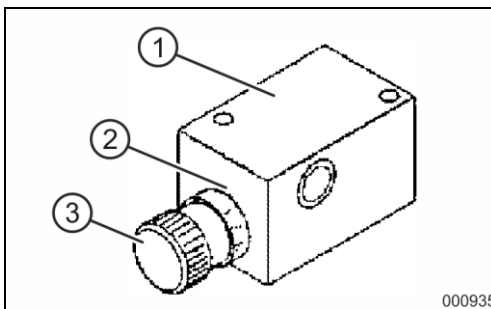

Fig. 67

6.15.1 Manually set conveyor speed

1. Set the conveyor speed directly on the machine via the rotary knob (3) at the flow regulation valve (1).
2. Position (2) indicates the scale value for the set conveyor speed:
 - Scale value 0 = lowest conveyor speed
 - Scale value 10 = highest conveyor speed.

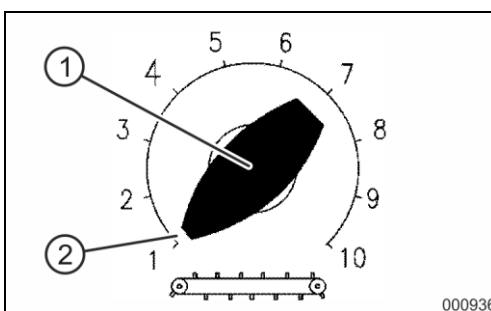

Fig. 68

6.15.2 Set conveyor speed via control set

1. Set the conveyor speed via the control dial (1) on the control set.
2. Pointer (2) indicates the scale value for the set conveyor speed:
 - Scale value 0 = lowest conveyor speed
 - Scale value 10 = highest conveyor speed.

6.15.3 Set control dial range of E-control set

The control range of the control dial of the E-control set and thus the drive speed of the conveyor belts can be adapted as required.

The control dial is factory-set such that in normal operating mode the conveyor slowly starts to run in position 2 and approximately reaches its maximum drive speed in position 10.

⚠ WARNING

Becoming entangled by powered conveyor

The running conveyor may catch clothing. Risk of injury due to being drawn in and wound up.

- Keep people and animals away from the hazardous area.
- Immediately switch the conveyor off if people or animals enter the hazardous area.



Fig. 69

1. Hitch the machine to the tractor.
 - Couple the drawbar.
 - Connect the flow and return line of the hydraulic system.
 - Connect the control set of the E-control.
2. Secure tractor and machine against rolling.
3. Pry the casing open.
 - Insert a screwdriver into the slit (1) on the right-hand side of the control set.
 - Press the handle of the screwdriver to the outside.

NOTE

The casing of the control set can only be completely folded open on the right-hand side.

4. Start the machine and switch the conveyor on.
5. Set the control dial (2) to position “2” (minimum operating speed).

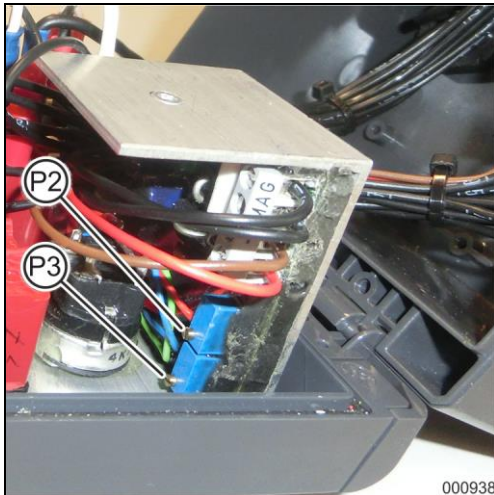

Fig. 70

6. Turn the screw at the trimmer potentiometer (P2) to change the minimum drive speed of the conveyor until it runs at the desired speed (current approx. 0.6 - 1.9 A).
7. Set the control dial to position "10" (maximum drive speed).
8. Turn the screw at the trimmer potentiometer (P3) to change the maximum drive speed of the conveyor until it runs at the desired speed (max. current 2.5 A).
9. Turn the control dial and observe the conveyor to finally check the entire control range.
 - Correct the control range via the trimmer potentiometers if necessary.

NOTE

With the control dial range being reduced, the other hydraulic functions are reduced as well as long as the conveyor is running.

In case of a conveyor failure, the other hydraulic functions can still be operated.

10. Close the casing of the control set.

6.16 Mount control set on the tractor

6.16.1 Mount holder for Bowden cable control set

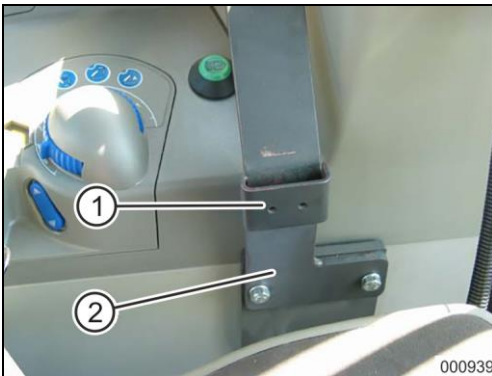

Fig. 71

The pocket is included in the scope of delivery.

1. Fix the holder (2) with the pocket (2) for the Bowden cable control set within easy reach at an appropriate spot in the tractor's cabin.
2. Insert the Bowden cable control set into the pocket (1).

6.16.2 Mount E-control set

Optional extra

The holder with mounting element is included in the scope of delivery.

1. Mount the holder (1) with the mounting element (2) for the control set on the tractor within view and easy reach to the driver's right.
2. Insert the mounting element for the control set into the holder.
3. Plug the 3-pole plug (DIN 9680) of the power supply cable into the 3-pole socket of the tractor.
 - Pole 15/30 = Plus
 - Pole 31 = Minus

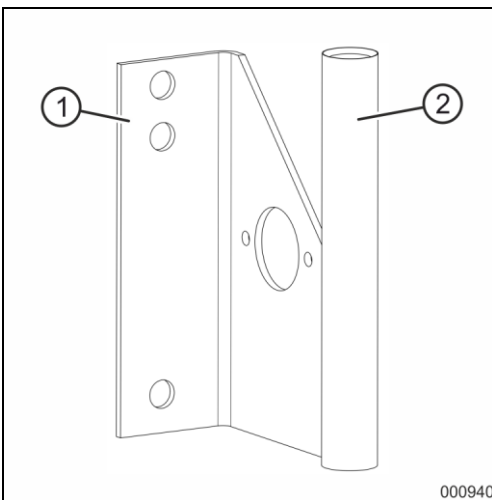

Fig. 72

NOTE

- Do not draw the current from the light socket.
- Retrofit the 3-pole socket if your tractor is not equipped with a 3-pole socket. An appropriate retrofit kit is available.
- A constant power supply of 12 V is required. The 3-pole socket must be protected by a fuse with a minimum rating of 25 A.
- The feed line of the 3-pole socket must have a minimum cable cross section of 4 mm².

6.17 Battery for weighing device

Optional extra

The battery of the weighing device enables the use of the weighing device when the machine is not connected with the tractor.

The signal lamp (1) displays the status of the system:

- flashes green: Battery is fully charged
- flashes red/green: Battery is being charged
- flashes red: The weighing device is supplied by the battery.

Press the button (2) to activate the power supply via the battery.

- The signal lamp flashes red.
- The weighing device is supplied with power for 45 minutes.

When the machine is connected to the tractor, the power supply is provided via the three-pole plug of the E-control set.

NOTE

If the voltage of the additional battery falls below 10.5 V, charging via the battery management is no longer possible.

In this case, a separate power supply unit with connecting cable is required.

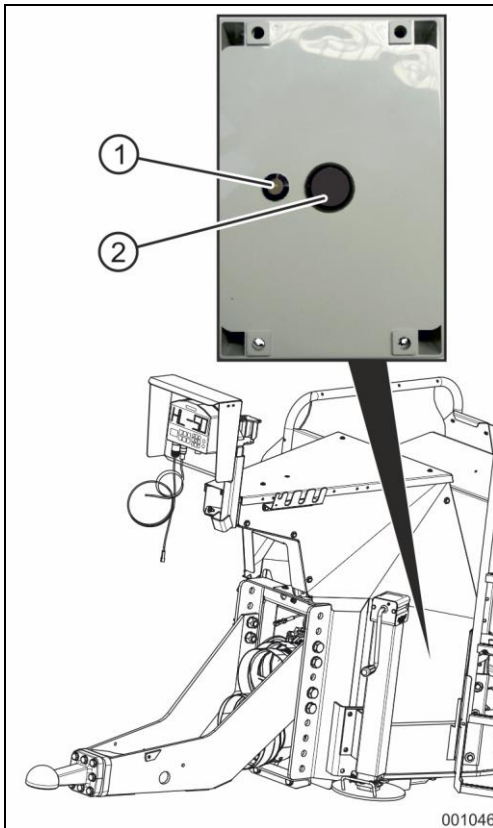

Fig. 73

The battery is charged if the three-pole plug of the E-control set is connected to the tractor. Precondition for the charging procedure is a socket in the tractor which is not switched via the ignition system. Otherwise, the battery is only charged with the ignition system switched on.

Approx. 11 hours are required to completely charge an empty battery. In order to ensure trouble-free operation, provide for a sufficient minimum charging time.

| Operation ¹⁾ | Charging time ²⁾ |
|-------------------------|-----------------------------|
| 15 minutes | 0.5 hour |
| 30 minutes | 1.0 hour |
| 45 minutes | 1.5 hours |
| 60 minutes | 2.0 hours |

Tab. 14: Operation and battery charging time

- 1) Operation of weighing device without connection to tractor
- 2) Minimum charging time of battery

If the required minimum charging time cannot be reached, an additional power supply unit will be required which enables charging of the battery independently of the tractor. The electronic system of the charging equipment prevents overcharging. The power supply unit is connected with the 3-pole plug of the E-control set by means of a charging cable.

6.18 Set deflector plate

WARNING

Machine movements

Unintentional movements of the machine or its working tools may cause serious injuries.

- Secure machine against accidental starting and rolling.

6.18.1 Mechanical deflector plate

1. Lower the dosage gate(s) completely.
2. Unscrew the nut (2).
3. Move the adjusting sheet (1)
 - up: the deflector plate (3) swivels out to its maximum extent when the dosage gate is lifted.
 - down: the deflector plate (3) swivels out to its minimum extent when the dosage gate is lifted.
4. Tighten the nut (2).

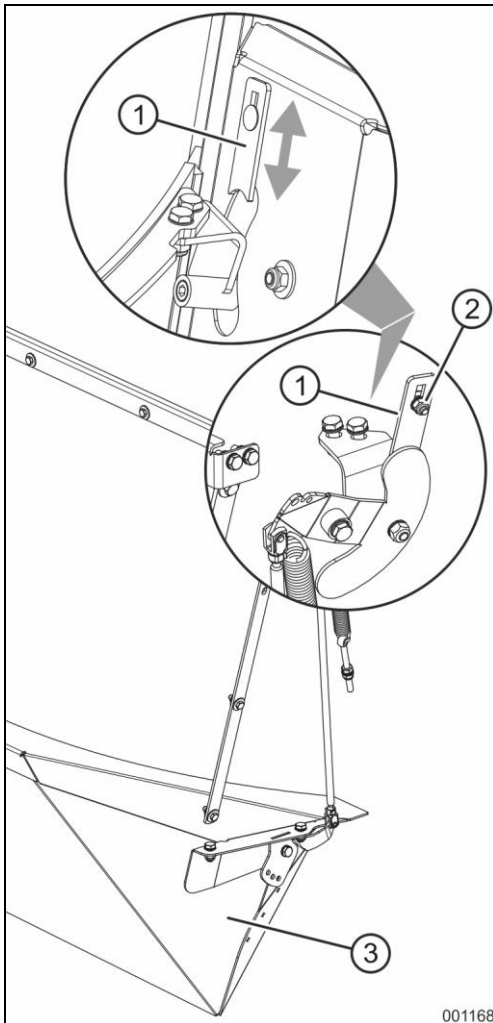

Fig. 74

7 Operation

Depending on the machine's equipment, the machine's hydraulic and electrical function(s) is (are) actuated via remote control from the tractor

- via direct tractor connection (standard equipment).
- via Bowden cable operation (optional extra).
- via electro-hydraulic operation (E-control) (optional extra).

NOTE

The actuating speed of the hydraulic components depends on the tractor's hydraulic system.

Depending on the tractor model, a correction of the set actuating speeds at the tractor's control device or the machine's control block may be necessary.

Information about the required control devices, ► see section 6.3, page 69.

7.1 Tractor direct connection

The individual hydraulic components of the machine are directly connected to the hydraulic system of the tractor via appropriate hydraulic hose pipes for oil supply.

A double-acting control device or a single-acting control device with depressurised return line is required on the tractor for each function (hydraulic component) of the machine.

The individual functions of the machine are actuated from the tractor via the operating element on the respective control device.



Fig. 75

7.2 Bowden cable control set

The individual hydraulic components of the machine are connected to a control block. For oil supply, the control block has been connected to the hydraulic system of the tractor via a double-acting control device or a single-acting control device and a free return line.

The Bowden cable control set serves to actuate the hydraulic functions of the machine from the tractor if the oil circulation between tractor and machine has been switched on via the control device on the tractor.

One operating element is required for each function of the machine.

The Bowden cable control set is equipped with one or several operating element(s) in touch-control or latch-in design:

- In touch-control design for folding, swivelling or sliding movable machine parts, e. g. dosage gate, hydraulic counter-cutters, supporting leg etc.

The function is only carried out if the operating element is actuated and held. If the operating element is released, it returns to its neutral position and the action is stopped.

- In latch-in design for movements requiring continuous action for constant loads e. g. hydraulic motors.



The operating elements can be set to three positions:

- Function I
- Neutral position
- Function II

7.2.1 Symbols on the control set

The following paragraphs show the possible symbols on the control set and their meaning.

Open and close dosage gate

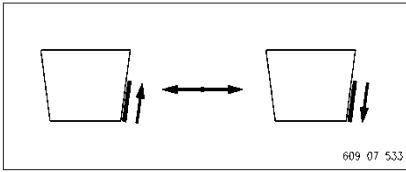
| Symbol | Position of hand lever | Dosage gate |
|--|------------------------|------------------|
|  | front (touch-control) | right open |
| | neutral position | no action |
| | rear (touch-control) | right close |
|  | front (touch-control) | left open |
| | neutral position | no action |
| | rear (touch-control) | left close |
|  | front (touch-control) | front/rear open |
| | neutral position | no action |
| | rear (touch-control) | front/rear close |

Switch crossover conveyor / conveyor extension / discharge conveyor

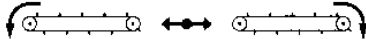
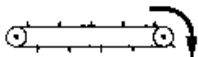
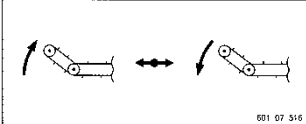
| Symbol | Position of hand lever | Crossover conveyor / Conveyor extension / Discharge conveyor |
|--|------------------------|--|
|  | front (latch-in) | crossover conveyor * on – to the left |
| | neutral position | crossover conveyor off |
| | rear (latch-in) | crossover conveyor * on – to the right |
|  | front (latch-in) | discharge conveyor on |
| | neutral position | discharge conveyor off |
| Symbol | Position of hand lever | Conveyor extension / Discharge conveyor |
|  | front (touch-control) | swivel up to transport position |
| | neutral position | action stops |
| | rear (touch-control) | swivel down to working position |

* At the same time, the conveyor extension is powered if a conveyor extension is mounted in the conveying direction of the crossover conveyor. If the material is conveyed away from the conveyor extension, the conveyor extension will stop.

Extend and retract counter-cutters

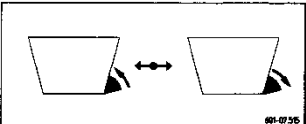
| Symbol | Position of hand lever | Counter-cutters |
|---|------------------------|-----------------|
|  | front (touch-control) | extend |
| | neutral position | no action |
| | rear (touch-control) | retract |

Lift and lower supporting leg

| Symbol | Position of hand lever | Supporting leg |
|--------|------------------------|----------------------------|
| | front (touch-control) | lift to transport position |
| | neutral position | no action |
| | rear (touch-control) | lower to support position |

Change mixing auger speed

| Symbol | Position of hand lever | Speed |
|--------|------------------------|-----------------------|
| | front (latch-in) | fast gear level I |
| | rear (latch-in) | slow gear level II |

Extend and retract deflector plate

| Symbol | Position of hand lever | Deflector plate |
|--------|------------------------|-----------------|
| | front (touch-control) | extend |
| | neutral position | action stops |
| | rear (touch-control) | retract |

Displace conveyor

| Symbol | Position of hand lever | Crossover conveyor |
|--------|------------------------|--------------------|
| | front (touch-control) | extend |
| | neutral position | action stops |
| | rear (touch-control) | retract |



Fig. 76

7.3 E-control set

The individual hydraulic components of the machine are connected to a control block. For oil supply, the control block has been connected to the hydraulic system of the tractor via a double-acting control device or a single-acting control device and a free return line.

The E-control set serves to actuate the hydraulic functions of the machine from the tractor if the oil circulation between tractor and machine has been switched on via the control device on the tractor.

One operating element is required for each function of the machine.

Depending on the machine's equipment, the control set design varies and is fitted with different operating elements such as key buttons, toggle switches and, where applicable, a control dial.

The operating elements are in touch-control design (key buttons), in latch-in design (toggle switches) or in control-dial design:

- In touch-control design for folding, swivelling or sliding movable machine parts, e. g. dosage gate, hydraulic counter-cutters, supporting leg etc.

The function is only carried out if the operating element is actuated and held. If the operating element is released, it returns to its neutral position and the action is stopped.

- In latch-in design for movements requiring continuous action for constant loads e. g. hydraulic motors.
- In control-dial design for setting the actuating speed of the hydraulic functions in 10 steps (e.g. conveyor speed for crossover conveyor / discharge conveyor).

The operating elements can be set to three positions:

- Function I
- Neutral position
- Function II

NOTE

In case of longer downtimes of the machine, switch the control set off, in order to avoid a discharging of the tractor's battery due to switched-on loads.

7.3.1 Symbols on the control set

The following paragraphs show the symbols of the operating and display elements of the control set and their functions.

Control lamps

| Symbol | Control lamp | Description |
|--------|--------------------------------------|---|
| | lights up red does not light up | control system on control system off |
| | not active | Lock and Unlock Steering Axle not active |
| | green – lights up red – lights up | power shift gearbox OK power shift gearbox malfunction |



Switch control set on and off

| Symbol | Position of toggle switch | Control set |
|--------|------------------------------|---|
| | top (latch-in design) | work lights on |
| | I – On Middle | on (red control lamp lights up) |
| | 0 – Off (latch-in design) | off (red control lamp does not light up) |



Change to a higher and lower gear

| Symbol | Position of key button | Switchgear |
|--------|-------------------------------|-----------------------|
| | top (touch-control design) | change to higher gear |
| | neutral position | no gear change |
| | bottom (touch-control design) | change to lower gear |



Switchgear in neutral position

| Symbol | Position of key button | Switchgear |
|---|-------------------------------|------------------------------------|
|  | top (touch-control design) | change to higher gear |
|  | neutral position | maintains setting |
|  | bottom (touch-control design) | switch third mixing auger on / off |

Open and close dosage gate

| Symbol | Position of key button | Dosage gate |
|--|-------------------------------|--------------|
|  | top (touch-control design) | open |
|  | neutral position | action stops |
|  | bottom (touch-control design) | close |

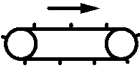
Displace conveyor

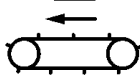
| Symbol | Position of key button | Crossover conveyor |
|---|-------------------------------|--------------------|
|  | top (touch-control design) | extend |
|  | neutral position | action stops |
|  | bottom (touch-control design) | retract |

Switch crossover conveyor / conveyor extension / discharge conveyor

| Symbol | Position of toggle switch | Crossover conveyor / Conveyor extension / Discharge conveyor |
|--------|-------------------------------|--|
| | top (latch-in design) | crossover conveyor * on – to the left |
| | neutral position | crossover conveyor off |
| | bottom (latch-in design) | crossover conveyor * on – to the right |
| | top (latch-in design) | discharge conveyor on |
| | neutral position | discharge conveyor off |
| Symbol | Position of key button | Conveyor extension / Discharge conveyor |
| | top (touch-control design) | swivel up to transport position |
| | neutral position | action stops |
| | bottom (touch-control design) | swivel down to working position |

* At the same time, the conveyor extension is powered if a conveyor extension is mounted in the conveying direction of the crossover conveyor. If the material is conveyed away from the conveyor extension, the conveyor extension will stop.

Set conveyor speed for conveyor belts

| Symbol | Position of control dial | Conveyor speed and other hydraulic functions |
|--------|--------------------------|--|
| | 1 | low |
| | 10 | high |

Extend and retract counter-cutters

| Symbol | Position of key button | Counter-cutters |
|--------|-------------------------------|-----------------|
| | top (touch-control design) | extend |
| | neutral position | action stops |
| | bottom (touch-control design) | retract |

Lift and lower supporting leg

| Symbol | Position of key button | Supporting leg |
|--------|-------------------------------|----------------------------|
| | top (touch-control design) | lift to transport position |
| | neutral position | action stops |
| | bottom (touch-control design) | lower to support position |

Change mixing auger speed

| Symbol | Position of key button | Speed |
|--------|---|-----------------------|
| | top (touch-control design) hold for at least 10 s | fast gear level I |
| | neutral position | remains constant |
| | bottom (touch-control design) hold for at least 10 s | slow gear level II |

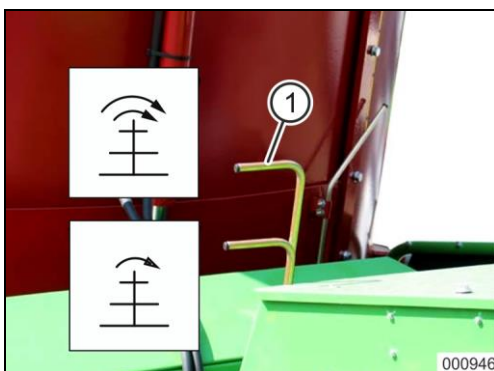

Fig. 77

NOTE

For changing the gear level, swivel the key button into the required position and keep hold of it there for at least 10 seconds.

The position of the indicator pipe (1) of the electrical remote control indicates the set speed (gear level).

| Indicator pipe | Speed |
|----------------|-------|
| top | fast |
| bottom | slow |

Extend and retract deflector plate

| Symbol | Position of key button | Deflector plate |
|---|-------------------------------|-----------------|
|  | top (touch-control design) | extend |
| | neutral position | action stops |
| | bottom (touch-control design) | retract |

Switch work lights on and off

| Symbol | Position of toggle switch | Work lights |
|---|---------------------------|-------------|
|  | top (latch-in design) | on |
| | bottom (latch-in design) | off |

Extend and retract fast bedding roller

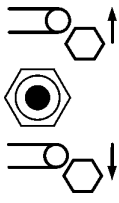
| Symbol | Position of key button | Fast bedding roller |
|---|-------------------------------|---------------------|
|  | top (touch-control design) | extend |
| | neutral position | action stops |
| | bottom (touch-control design) | retract |

Switch fast bedding roller on and off

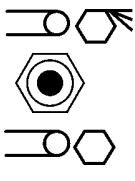
| Symbol | Position of key button | Fast bedding roller |
|---|-------------------------------|---------------------|
|  | top (touch-control design) | on |
| | neutral position | stops |
| | bottom (touch-control design) | stops |

7.4 Information display for power shift gearbox

7.4.1 Display information

The information display only serves to visualise data and provides the status data of the power shift gearbox. The following information is displayed:



Fig. 78

| No | Display | Values |
|----|-----------------|---|
| . | | |
| 1 | System status | <ul style="list-style-type: none"> Start-up Automatic start-up Shut down Gear change Gear engaged Error |
| 2 | Speeds | <ul style="list-style-type: none"> Input speed Output speed |
| 3 | Temperature | <ul style="list-style-type: none"> Oil temperature in control valve |
| 4 | Gear level | N = Neutral 1 = 1 st gear with high reduction ratio 2 = 2 nd gear 3 = 3 rd gear with low reduction ratio * = Gear change |
| 5 | Pressure values | <ul style="list-style-type: none"> Main line at control valve Pressures in the clutches <ul style="list-style-type: none"> 1st gear 2nd gear 3rd gear (if available) |

Tab. 15: Display information

7.4.2 Navigation layout of displays

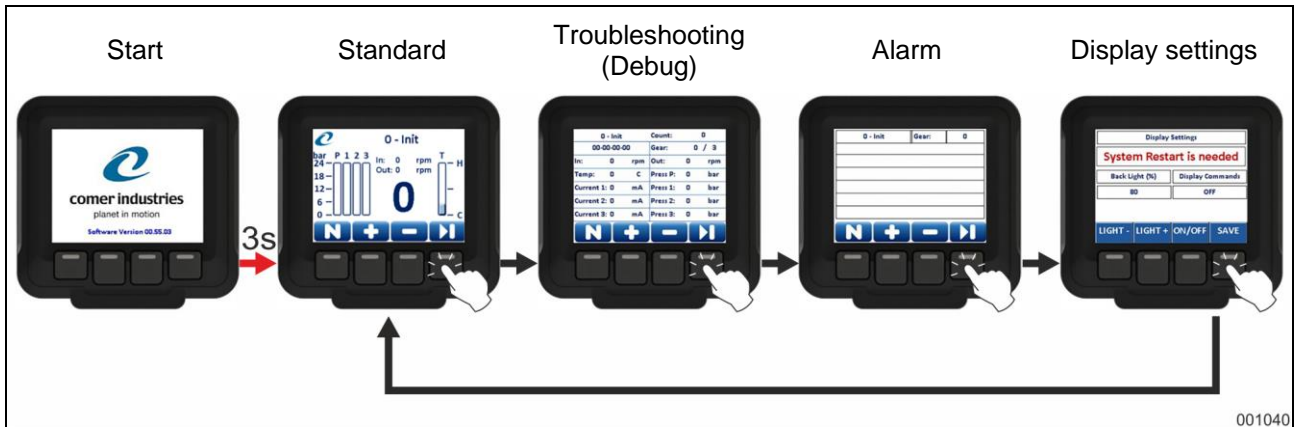

Fig. 79

7.4.3 Displays

Start

Appears for 3 seconds during the start only. Display of logo and software version.



Fig. 80

Standard

Status data of gearbox with numerical values and graphic display.

- 1 Error or system status
- 2 Speeds
- 3 Oil temperature display
- 4 Engaged gear or gear change
- 5 Key button: Continue to next display
- 6 Pressure displays



Fig. 81

NOTE

The other key buttons do not have any function in this display.



Fig. 82

Troubleshooting (Debug)

Display of all data information with numerical value.

- 1 Error or system status
- 2 Switch counter
- 3 Engaged gear or gear change
- 4 Output speed
- 5 Pressure displays
- 6 Key button: Continue to next display
- 7 Current values of control valves
- 8 Oil temperature
- 9 Output speed

NOTE

The other key buttons do not have any function in this display.



Fig. 83

Alarm

Display of error and warning messages.

- 1 Error or system status
- 2 Engaged gear or gear change
- 3 Messages
 - Blue entries = Warnings
 - Red entries = Errors
- 4 Key button: Continue to next display

NOTE

The other key buttons do not have any function in this display.



Fig. 84

Display settings

Change of operating mode and display brightness.

- 1 Message if restart is required
- 2 Display of operating mode
 - OFF = Only data visualisation
 - ON = Check on
- 3 "Save" key: Save settings and continue to next display
- 4 Key: Operating mode "Check" ON/OFF
- 5 Key: Display brighter
- 6 Key: Display darker
- 7 Display of screen brightness

8 Operation

8.1 Safety

As a basic principle, the following is applicable:

- Acquaint yourself with all mechanisms and operating elements of the machine and their functions before starting work. During operation will be too late.
- Wear close-fitting clothing. Loose-fitting clothing may be more easily caught by moving machine parts.
- Start the machine only if all protective devices have been installed and are in protective position.
- It is not allowed to open protective devices.
 - when the machine is powered.
 - as long as the tractor engine is running with the propeller shaft coupled / the hydraulic system connected.
 - if the ignition key is in the tractor and the tractor engine can be accidentally started with the propeller shaft coupled / the hydraulic system connected.
 - if tractor and machine have not been secured against accidental rolling by means of their respective parking brake and/or the chocks.
- Immediately replace missing or defective protective devices.
- Observe the maximum payload of the attached / hitched machine and the admissible axle and tongue loads of the tractor. Run the machine when only partly filled if necessary.
- People are not allowed
 - within the operating/hazardous area of the machine.
 - within the discharge area of the machine.
 - within the turning and swivelling range of movable machine parts.
 - beneath lifted and unsecured movable machine parts.
- Immediately switch the tractor's p.t.o. shaft off in case of a response of the overload clutch.

- Only actuate powered machine parts if there are no people within the machine's hazardous area.
- Secure tractor against accidental starting and rolling before leaving the tractor.
- Check the hazardous area behind the machine before starting reverse travel. If a rear-view camera (optional extra) is available, set it such that you have a complete view of the rear hazardous area.
- Safely support folded-up covers before working beneath them.

Operative staff:

- Operator
-

8.2 Fill machine

As a basic principle, the following is applicable:

- The mixing container must be charged by means of appropriate equipment, such as:
 - Tractor with front loader
 - Yard or wheeled loader
 - Telescopic loader
 - Conveyor system
- People are not allowed on a level with or above the mixing container.
- People are only allowed to fill the mixing container manually if they cannot accidentally fall into the mixing container.
- As a basic principle, fill pourable fodder additives (e. g. mineral feed) into the mixing container by means of the loading tool (loading shovel), through the feed funnel (optional extra) or via a conveyor system.
- Fill liquid or sticky fodder additives into the mixing container by means of the loading tool (loading shovel):
 - Fill the loading shovel only partly.
 - Form a hollow in the grass or maize silage.
 - Fill the fodder additives into the hollow.
- Alternatively: Add fodder additives via a conveyor system.
- Remove baler twine and nets on the ground before filling round or cuboid bales into the mixing container by means of the loading tool.
- When filling the mixing container, ensure that the tractor engine runs as smoothly as possible when powering the mixing auger, i.e. without variations in the tractor engine speed.

Variations in the tractor engine speed indicate insufficient engine power of the tractor and cause additional load to all powered components.

The required tractor power can be reduced by means of a two-level switchgear (optional extra) in the power train of the mixing auger.

- Due to the different fodder components to be mixed, the filling quantity for one mixing container filling cycle may vary. Avoid overload; in case of overload
 - the individual fodder components cannot be mixed homogeneously.
 - mechanical damage to the power train may occur.
 - cutting knives of the mixing auger may bend.

⚠ WARNING**Failure of components due to overload**

Overload may cause insufficient stability, steering and braking ability of the tractor. Risk of accident.

- Observe the maximum load capacity of the hitched machine.
- Observe the admissible axle and tongue loads of the tractor; run the machine only with partly-filled mixing container if necessary.

ATTENTION**Damage to the machine due to overload**

Overload affects the machine's performance and service life and may occur

- if fodder components become entangled by the counter-cutters and blockages pile up.
- when loosening round bales,
- due to blunt knives.

The fodder components should freely move in the mixing container when the mixing auger is powered.

- Observe the maximum load capacity of the machine and the filling order of the individual fodder components.

NOTE

If only one tractor is available, the mixing container can also be charged when unhitched. The mixing process is, however, accelerated if the mixing auger is powered during filling.

If the mixing auger is switched on only after filling or transport journeys, more power will be required to set the fodder components to be mixed in motion.

The total fodder quantity that can be mixed and chopped in one mixing container filling cycle depends on the following factors:

- Mixing container capacity
- Total dry mass of the fodder components to be mixed
- Structure (stalk length and quality) of the individual fodder components
- Way and order of filling
- Tractor power.

8.2.1 Filling procedure

1. Check the mixing container for foreign objects before starting the tractor.
 - Remove foreign objects from the mixing container if necessary.
2. Start the tractor engine.
3. Park the tractor with the hitched machine on even ground.
4. Align tractor in a straight line in front of the machine.
 - Further angular misalignment of the propeller shaft causes increased wear.
5. Secure tractor and machine against rolling.
6. Close open dosage gates if applicable.
7. Swivel the weighing device (if available) from the tractor into filling direction.
8. Switch the weighing device on and start the programme (if available).
9. Keep people away from the hazardous area (loading area).
10. Switch tractor's p.t.o. shaft on (not in case of power shift gearbox).
 - The mixing auger starts.
11. Let the tractor engine run at appropriate speed to ensure that the tractor engine runs smoothly and does not stall when the mixing container is being filled.
12. Fill the mixing container.
 - By means of appropriate equipment (e.g. tractor with front loader, yard or wheeled loader).

8.2.2 Filling order

NOTE

For loosening round or cuboid bales, a higher power is required. Change to second or third gear to reduce the power required.

Recommended procedure for processing round or cuboid bales:

1. Extend the counter-cutters into the mixing container.
 2. Fill round or cuboid bales in at slow mixing auger drive speed.
 3. Increase the drive speed of the mixing auger after the bale has been loosened.
 4. Retract the counter-cutters from the mixing container.
-

1. Fill highly-structured fodder components (hay, straw etc.) in with the mixing auger powered.
Have them possibly mixed for a short time before filling in the next component. A longer mixing ensures better chopping of the long stalks.
2. Fill in grass silage.
3. Fill in maize silage, grain silage.
4. Fill in concentrated feed, grain feed etc.
5. Fill in mineral feed by means of the loading tool (shovel), through the feed funnel (optional extra) or via a conveying system.
6. Fill in fodder components with a high proportion of water, e.g. draff, potato pulp or beet chips
7. Fill liquid components such as liquid yeast, molasses into the mixing container by means of the loading tool together with the last portion of maize silage.

8.3 Mix fodder components

The type and structure of the used fodder components and the desired cutting length of the fodder mixture determine the duration of the last mixing cycle.

The mixing process will be extended for highly-structured fodder components which must be cut.

1. **▲ WARNING** – Risk of falling into the mixing container. Do not bend over the mixing container. Monitor the mixing process from the ladder.
2. Stop the mixing process when the fodder components have been homogeneously mixed.
In case of a too long mixing process, the mixture risks to lose its structure.
3. Reduce the drive speed of the mixing auger if light fodder components are thrown over the edge of the mixing container during mixing.
4. Extend the counter-cutters if necessary.

NOTE

The use of the counter-cutters allows finer chopping and faster mixing of highly-structured fodder components. ► See the following paragraph.

NOTE

Sharp cutting knives reduce the required mixing auger power. Regularly sharpen cutting knives, ► see section 10.13.2.1, page 198.

8.3.1 Mount counter-cutters

Depending on the structure of the fodder components, the counter-cutters can be extended into the mixing container at four possible positions.

- Extend the counter-cutters only with the mixing auger stopped.
- Extend the counter-cutters into the mixing container only as far as to ensure that the fodder will not get entangled by / pile up on the counter-cutters.
- The counter-cutters slow down the horizontal revolving of the fodder in the mixing container and serve e. g. for chopping and mixing round or cuboid bales.
- The further the counter-cutters protrude into the mixing container, the better their effect and the larger the slowing-down effect.

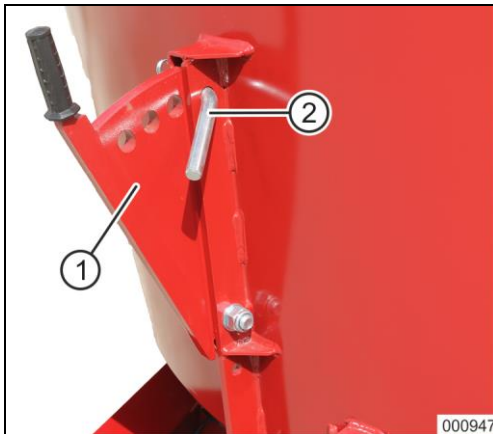

Fig. 85

Standard equipment (manual adjustment)

1. Pull the locking bolt (2) out.
2. Extend or retract the counter-cutter (1).
3. Insert the locking bolt (2) into the desired position.

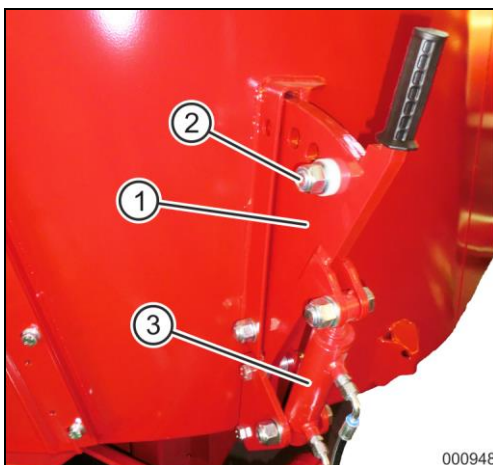

Fig. 86

Optional extra (hydraulic adjustment)

The optional extra equipment of the counter-cutters (1) includes a hydraulic cylinder (3) enabling extending and retracting via remote control.

The hydraulic cylinders enable the extension of the counter-cutters in four possible positions by placing the bolt (2) respectively.

Depending on the tractor's equipment, remote control is effected:

- directly via a double-acting control device of the tractor,
- via Bowden cable operation,
- via E-control.

8.4 Discharge fodder

Important information for fodder discharge:

- Open the dosage gate completely when discharging very dry, long-stalk and highly-structured fodder.
- Open the dosage gate according to the desired discharge quantity when discharging highly pourable fodder.
- When discharging the fodder, the 750 p.t.o. shaft (if available) can be used and the tractor engine can be run at reduced speed.
- Increase the drive speed of the mixing auger for a short time towards the end of the discharging process to throw off any fodder residues from the mixing auger and to completely empty the mixing container.
 - Gear level II or p.t.o. shaft speed 1000 min⁻¹
 - Select second or third gear for power shift gearbox.
- The opening width of the dosage gate is indicated on the scale at the dosage gate.
 - Scale value 0: Dosage gate is closed. No fodder discharge.
 - Scale value 7: Dosage gate is completely open. Maximum fodder discharge.

The fodder discharge can be started after the mixing process has been finished.

The fodder quantity discharged onto the feeding table is set via

- the drive speed of the mixing auger.
- the opening width of the dosage gate.
- the travelling speed of the tractor on the feeding table.

The higher the drive speed of the mixing auger, the wider the opening width of the dosage gate, and the slower the travelling speed of the machine, the larger the fodder quantity discharged onto the feeding table.

8.4.1 Discharge procedure

⚠ WARNING**Objects being flung out**

Risk of objects being flung from the conveyor belt through the discharge opening and causing injuries during fodder discharge.

- Make sure that people and animals leave the hazardous area before switching the conveyor belt on and opening the discharge openings.

Keep to the specified order during discharge.

Note: Optional extras are put in parentheses (...).

Start discharge

1. (Set conveyor belt to working position if it can be swivelled/moved, ► see section 8.11, page 153.)
2. Switch p.t.o. shaft on.
3. (Switch conveyor belt on.)
4. Switch mixing auger on.
5. Open dosage gate.

Finish fodder discharge

1. Close dosage gate.
2. Switch mixing auger off.
3. (Switch conveyor belt off when the fodder discharge has been finished.)
4. Switch p.t.o. shaft off.
5. (Set conveyor belt to transport position if it can be swivelled/moved, ► see section 8.11, page 153.), .)

8.4.2 Eliminate blockages

⚠ WARNING

Unsecured machine parts

Increased risk of accident due to unsecured parts or uncontrolled machine movements.

- Secure lifted parts against lowering, e.g. open dosage gate.
- Secure machine against accidental starting and rolling.
- Wait for the machine to stop completely before entering the hazardous area.

⚠ CAUTION

Sharp-edged cutting knives

Sharp-edged cutting knives of the mixing auger may be within the discharge opening area. Risk of cuts.

- Do not reach into the cutting knives when eliminating blockages.
- Wear cut-resistant protective gloves.

ATTENTION

Machine damage due to change of sense of rotation

- Never change the sense of rotation of the tractor's p.t.o. shaft to eliminate blockages.

1. Switch the p.t.o. shaft off.
2. Completely open the dosage gate of the clogged discharge opening if necessary.
3. Secure tractor and machine against accidental starting and rolling
4. Eliminate the blockage, such that the discharge opening gets free and the mixed materials can be easily discharged again.
5. Start the tractor engine.
6. Close the dosage gate.
7. Switch the p.t.o. shaft on.
8. Power the mixing auger at the desired drive speed.
9. Open the dosage gate.
 - Set the desired opening width.
10. Continue fodder discharge.

8.5 Working with the fast bedding roller

Optional extra

Bedding substrates such as straw, peat, horse dung and lime are added to the fodder by means of the fast bedding roller.

- The spreading range is controlled by means of the speed of the fast bedding roller.
- The spreading quantity is controlled by means of the opening width of the dosage gate.

Important information about working with the fast bedding roller:

- Mix the bedding substrates in the mixing container to obtain a homogeneous mixture.
- Make sure that the mixture possesses sufficient density. Add water if necessary. If the density is too low, the spreading range will be considerably reduced.
- For chopping the straw, extend the counter-cutters a little further into the mixing container if necessary.
- Swivel the fast bedding roller completely to its transport position before transport journeys.

WARNING

Risk of crushing and being drawn in at the fast bedding roller

Risk of crushing to hands and arms when swivelling the fast bedding roller to transport or working position. The rotating fast bedding roller may catch and draw in clothing as well as parts of the body.

- Keep people and animals away from the hazardous area.

WARNING

Materials being flung out

Risk of injuries due to substances and foreign objects being flung out by the rotating fast bedding roller.

- Keep people and animals away from the hazardous area.
- Keep the bedding material free from foreign objects (e.g. stones).



Fig. 87

8.5.1 Start bedding

1. Make sure that people and animals leave the hazardous area of the machine / the fast bedding roller.
2. Select gear level II at the switchgear or select second or third gear for the power shift gearbox.
3. Swivel the fast bedding roller to its top position (working position).
 - Observe the local conditions; keep minimum distance.
4. Switch tractor's p.t.o. shaft on.
5. Switch the crossover conveyor on.
6. Switch the fast bedding roller on.
 - Press and hold the key button.
7. Open the dosage gate.
8. Set the desired spreading range.
 - Set the throwing range by setting the beater speed.
9. Set the spreading quantity by means of the opening width of the dosage gate.

8.5.2 Finish bedding

1. Close the dosage gate.
2. Switch the p.t.o. shaft off.
3. Switch the crossover conveyor off only when the discharge of bedding substrate has finished.
4. Switch the fast bedding roller off.
5. Swivel the fast bedding roller to its bottom position (transport position).
 - The fast bedding roller is in transport position only when the hydraulic cylinder has been completely retracted.



Fig. 88

8.6 Change gear level by means of switchgear

The mixing augers can be alternatively powered at gear level I or II providing different speeds.

| Gear level I | |
|-------------------------|--|
| Increased driving speed | <ul style="list-style-type: none"> • for producing small mixing quantities • for emptying the mixing container |
| Gear level II | |
| Increased driving speed | <ul style="list-style-type: none"> • for mixing with the mixing container completely filled • when using a tractor with low driving power • when starting a filled container to loosen up the contents • when using a straw blower |

Tab. 16: Gear levels | Switchgear

The switchgear is not synchronised. Changing gear level is only possible when the vehicle is stationary or when it is coasting or starting at low speed.

Different steps may therefore be necessary for changing gear level by means of the switchgear.

The steps depend on:

- the type of actuation of the tractor's p.t.o. shaft:
 - After the p.t.o. shaft has been switched off, the p.t.o. shaft drive of the tractor is slowed down during coasting and when stationary,
 - the p.t.o shaft coupling engages very fast when the p.t.o. shaft is switched on.
- the type of remote control of the switchgear:
 - Mechanical remote control via Bowden cable
 - Electrical remote control via control set
- the amount of load of the mixing auger in the mixing container:
 - Empty or slightly filled mixing container
 - Fully filled mixing container

Two different procedures for changing gear level by means of the switchgear are described below.

8.6.1 Change gear level with small amount of load

Procedure for changing the gear level with an empty or slightly filled mixing container – small amount of load of mixing auger:

1. Switch tractor's p.t.o. shaft off.
 2. Select the gear level via the mechanical or electrical remote control set.
 3. Switch tractor's p.t.o. shaft on.
- During restart of the p.t.o. shaft, changing the gear level is initiated in the switchgear.

8.6.2 Change gear level with large amount of load

Procedure for changing the gear level with fully filled mixing container – large amount of load of mixing auger:

1. Switch tractor's p.t.o. shaft off.
 2. Prepare for change of gear level:
 - Switch tractor engine off if the p.t.o. shaft drive of the tractor is slowed down during coasting and when stationary after the p.t.o. shaft has been switched off.
 - In this state, the p.t.o. shaft is freely movable.
 - Select the function "Switched-off p.t.o. shaft freely movable with the tractor engine running" at your tractor (if available).
 3. Select the gear level via the mechanical or electrical remote control set.
 4. Switch tractor's p.t.o. shaft on.
- During restart of the p.t.o. shaft, changing the gear level is initiated in the switchgear.

8.7 Change gear level at power shift gearbox

Optional extra

As optional equipment, a 2-gear or 3-gear power shift gearbox is installed in the power train of the mixing augers.

The power shift gearbox serves to change the mixing auger speed under load, which means without interruption of the tractive force. As opposed to a usual gearbox, it is not necessary to change the gears during standstill. Instead, the gear levels of the power shift gearbox are controlled via the E-control.

The current gear level is indicated in the display. Among others, input and output speed as well as the oil temperature are displayed. For detailed information about E-control,



► see section 7.3, page 123.

Working conditions for the power shift gearbox

| Input speed | |
|-------------------------------|--|
| 300 to 1000 min ⁻¹ | Only operable in this speed range |
| Oil temperature | |
| -20 °C to 0 °C | Switching only possible in 1 st gear, oil temperature too low |
| 0 °C to 90 °C | Switching possible in all gears, normal operation |
| 90 °C to 95 °C | Switching only partly possible, oil temperature too high |
| below -20 °C above 95 °C | Not operable, gearbox in neutral position |

Tab. 17: Power shift gearbox | Speed and oil temperature

Change gear level

1. Switch tractor's p.t.o. shaft on.
→ The gearbox works in neutral position.
2. Increase input speed of p.t.o. shaft to at least 300 min^{-1} .
3. Run oil at low speed to operating temperature.
4. Press the  key button at the E-control set up.
→ The gearbox switches to 1st gear, mixing starts.
 - Press the  key button again to change to a higher gear.
5. Switch the power shift gearbox to neutral position to finish mixing.
 - Press the  key button at the E-control set down.

8.8 Emergency draining by means of power shift gearbox

If a gear cannot be engaged in case of damage to the power shift gearbox, another stub is available on the through shaft beneath the gearbox input shaft. This stub serves to empty the mixing container in case of an emergency.

1. Unscrew the frame plate (1).

NOTE

It is imperative to reinstall the frame plate after completion of the emergency emptying.

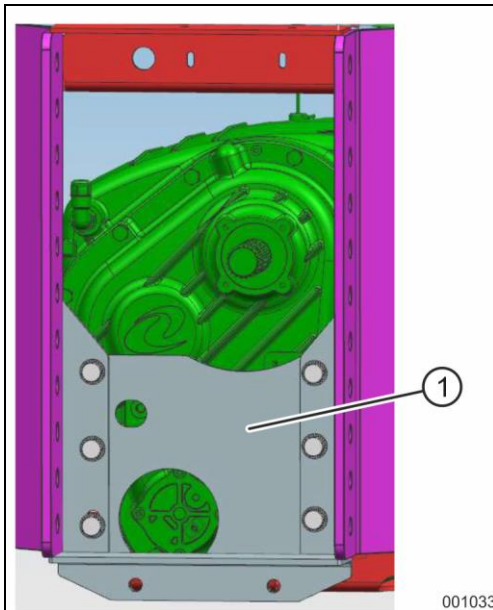

Fig. 89

2. Unscrew the protective cap (1).
3. Slip the propeller shaft onto the exposed stub (2) of the through shaft.

NOTE

During emergency emptying, gear reduction cannot be used. Therefore, it is useful to initially only empty the first mixing auger. Pull off the propeller shaft behind the first angular gear for this purpose. *Only qualified staff is authorised to carry out this work.*

Slip the propeller shaft on again after emptying the first mixing auger. Pull off the propeller shaft behind the second angular gear in the same way to empty the second mixing auger.

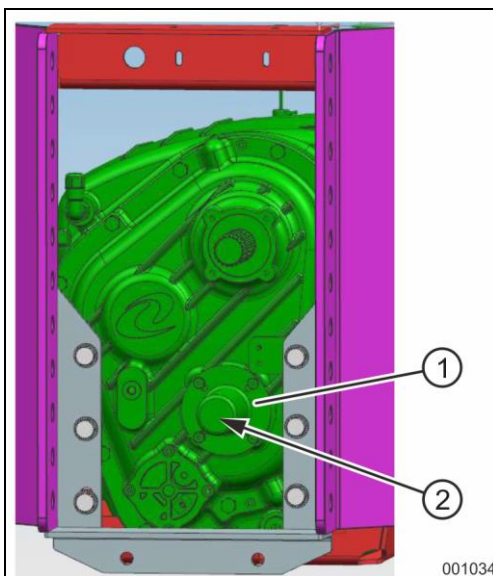

Fig. 90

After the emergency emptying:

1. Pull off the propeller shaft from the stub of the through shaft.
2. Screw on the protective cap.
3. Screw on the frame plate.
4. Have damage at the power shift gearbox remedied by an authorised workshop.

8.9 Transport journeys

A transport journey is a journey of the charged or empty machine to or from the place of operation.

As a basic principle, the following is applicable:

- Observe the national road traffic regulations.
- Adapt driving to the conditions. Consider personal abilities as well as the road, cornering, traffic, visibility and weather conditions, the driving characteristics of the tractor and the influences exerted by the attached/hitched machine.
- Avoid sudden changes of direction, particularly when travelling uphill and downhill and when traversing hills. Risk of tipping.
- Shift down to a lower gear before travelling downhill.
- Observe the broad overhang and the flywheel mass of the machine when cornering with attached/hitched machine.
- Observe the maximum payload of the attached/hitched machine and the admissible axle and tongue loads of the tractor.
- The tractor's front axle load must never fall below 20 % of the tractor's empty weight, in order to ensure sufficient steerability. Use front weights if necessary.
- Ensure sufficient steerability and braking ability of the tractor. Machines attached or hitched to a tractor and front or tail weights influence the driving behaviour as well as the steerability and the braking ability of the tractor.

Before carrying out transport journeys, check:

- the supply lines for proper connection.
- the lighting system for damage, proper functioning and cleanliness.
- the brake and hydraulic system for visible defects.
- Lock the steering axle if necessary, e.g. on uneven tracks (optional extra).
- whether the parking brake has been completely released.
- the brake system for proper functioning and the braking effect. The tractor must ensure the specified deceleration for the combination of tractor and machine.
- whether parts of the loaded material risk to fall off the machine onto the road.
- whether all movable machine parts are in transport position secured by the provided transport locks.
- whether the work lights are switched off.
- whether the single-wheel brake system is switched off; the pedals are locked.
- the transport equipment for proper installation, e.g. lighting, warning and protective devices.

⚠ WARNING**Machine movements**

Risk of dangerous situations to people due to machine movements caused by unintentional actuation of the hydraulic system.

Before carrying out transport journeys:

- switch the control set off.
 - switch the oil circulation between tractor and machine off.
 - switch off the propeller shaft if an on-board hydraulic system is available.
-

NOTE

Always switch the work lights off when travelling on public roads.

8.10 Secure protective devices

1. Secure the protective devices (1) by means of an elastic strap (2) during side or rear discharge.



Fig. 91

8.11 Secure discharge conveyor or conveyor extension

Disable the hydraulic system to secure the discharge conveyor for side discharge or the conveyor extension in transport position.

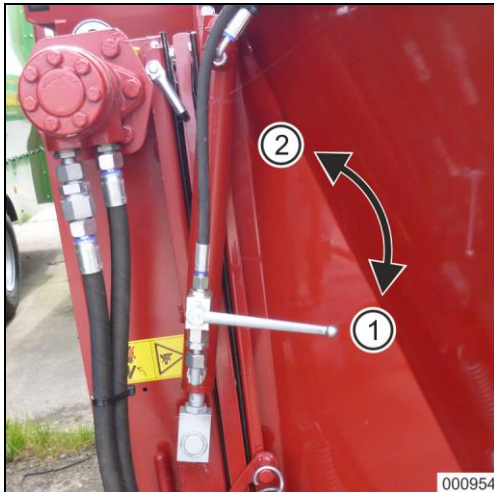

Fig. 92: Version with short conveyor
(1 hydraulic cylinder)

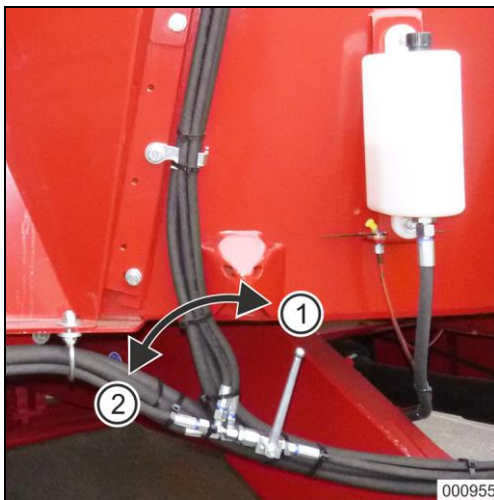

Fig. 93: Version with longer conveyor
(2 hydraulic cylinders)

⚠ WARNING

Fold out discharge conveyor and conveyor extension

Risk of road accident due to unintentional folding-out of the discharge conveyor during road travels.

Before carrying out transport journeys

- place the discharge conveyor in transport position.
- close the stop-cock.

Before road journeys

1. Use the control set to swivel the discharge conveyor to transport position.
 - The discharge conveyor is in transport position only when the hydraulic cylinder has been completely retracted.
2. Move the lever to position (1): Shut-off valve is closed.

Before fodder discharge

1. Move the lever to position (2): Shut-off valve is open.
2. Use the control set to swivel the discharge conveyor to working position.

8.12 Safely park tractor and machine

Risk due to accidental contact with powered, unsecured working tools and lifted, unsecured machine parts when carrying out work on the machine.

Therefore, safely park the tractor and the hitched machine before carrying out any work on the machine such as e.g. adjusting work or trouble-shooting.

1. Park the tractor and the machine on firm, even ground.
2. Lower lifted, unsecured machine parts to a secure stop position.
3. Apply the tractor's parking brake.
4. Turn the tractor engine off.
5. Pull the ignition key out.
6. Keep third parties, particularly children, away from the hazardous area between tractor and machine.
7. Lock the tractor cabin.
 - Make sure that tractor and machine cannot be started by third parties.
8. Use the chocks to secure the machine against accidental rolling.

9 Malfunctions

9.1 Safety

Malfunctions specified in this chapter must be eliminated by qualified staff authorised and trained by the user or by an authorised workshop.

Observe the general occupational safety, accident prevention rules and the applicable documents such as the sub-supplier documentation.

Contact the manufacturer in case of malfunctions not specified below.

As a basic principle, the following is applicable:

- Park the machine on firm, even ground.
- Safely park the machine and secure it against accidental rolling.
- Secure lifted machine parts against accidental lowering.
- Keep people away from the hazardous area.
- Only carry out work with the machine stopped.
- If safety and/or protective devices must be removed, reinstall them immediately after completion of work and check them for proper functioning.
- Wear personal protective equipment required for the respective work to be carried out.
- Have work on the electrical system only carried out by qualified electricians.
- Risk of accident due to damaged safety-related parts; immediately replace damaged parts.
- Malfunctions affect the safe operation of the machine. Immediately eliminate detected malfunctions.
- Ensure tidiness and cleanliness in the operating area.
- Observe all safety and warning instructions in the operating instructions.

9.1.1 List of malfunctions, machine

| Malfunction | Cause | Remedy |
|--|--|--|
| The power requirement is too high, shear bolt of the shear bolt coupling in front of the angular gear shears off | Cutting knives blunt | Sharpen cutting knives |
| | Long stalks have wrapped around the front auger end or the scraper | Clean mixing auger |
| | Foreign objects are jamming the mixing auger | Eliminate foreign objects |
| | Screwed connection of the mixing auger has loosened | Retighten screwed connection |
| Mixing auger does not rotate with the p.t.o. shaft powered | Gear levels at the switchgear not selected clearly | Clearly select gear level I or II |
| | Shear bolt of the shear bolt coupling in front of the angular gear sheared off | Replace shear bolt |
| Machine does not mix well | Fodder is piling up in front of counter-cutter | Extend and retract counter-cutter |
| Non-uniform discharge | All cutting knives retracted (out) | Extend lower cutting knives |
| Crossover conveyor does not start | Operating error | First switch crossover conveyor on, open dosage gate only then |
| | Crossover conveyor too loose | Tighten crossover conveyor |

Tab. 18: List of malfunctions, machine

9.1.2 List of malfunctions, electrical system

| Malfunction | Cause | Remedy |
|---|--|--|
| Electro-hydraulic operation does not work (all functions) | No power (12 V) at the control set | Plug 3-pole plug (DIN 9680) into the socket for the tractor's power supply |
| | Polarity of plug and socket are not compatible | Check polarity of plug and socket and reconnect if necessary |
| | Fuse for socket defective | Replace fuse |
| | Fuse for control set defective | Replace fuse |
| | Insufficient power supply and amperage | |
| Check power supply, plugs and cables | | |
| One of the electrically operated functions does not work | Insufficient power supply | Check switches etc. (measurement at the valve plug) |
| | Control valve blocked | Check via emergency operation function |
| Functions work irregularly | Cable cross sections of feed line too small | Select larger cable cross section, minimum 4 mm ² |

Tab. 19: List of malfunctions, electrical system

9.1.3 List of malfunctions, weighing device

NOTE

It is absolutely imperative to observe the enclosed operating instructions for the weighing device.

| Malfunction | Cause | Remedy |
|--------------------------------------|--------------------------------------|---|
| Device cannot be switched on | No power supply | Check connecting cable Switch power supply on, check power supply battery |
| | Wrong polarity | Check polarity connecting cable (the devices are equipped with an automatic fuse) |
| Device displays bars (top or bottom) | Device | Pull the terminal box plug out of the weighing computer and watch display. If the bars disappear, the weighing computer functions properly. |
| | Terminal box | Pull out the plugs of all weighing rods, the terminal box being plugged into the weighing computer. Watch display. If the bars disappear, the display functions properly. |
| | Weighing rods | Always plug only one weighing rod at a time into the terminal box or directly into the weighing computer. If the bars disappear, the respective weighing rod functions properly. |
| Weighed value varies | Device | See malfunction description: "Device displays bars" |
| | Terminal box | |
| | Weighing rods | |
| Scale displays wrong weighed value | Weighing rods not properly installed | Always plug only one weighing rod at a time into the terminal box or directly into the weighing computer. The displayed value must increase when load is applied. Always test all rods. |
| | Weighing system misadjusted | Readjust scale, see enclosed operating instructions "Recalibration". |
| Device displays ERROR | Internal error | Send device in for repair. |

Tab. 20: List of malfunctions, weighing device

9.2 Emergency manual operation

In case of a failure of the electrical system, the hydraulic functions can be actuated via the emergency manual operation function.

Operative staff:

- Qualified staff

⚠ WARNING

Movements of working tools

Risk of dangerous situations to people caused by unintentional movements of working tools due to the actuation of the emergency manual operation function.

- Keep people away from the hazardous area.

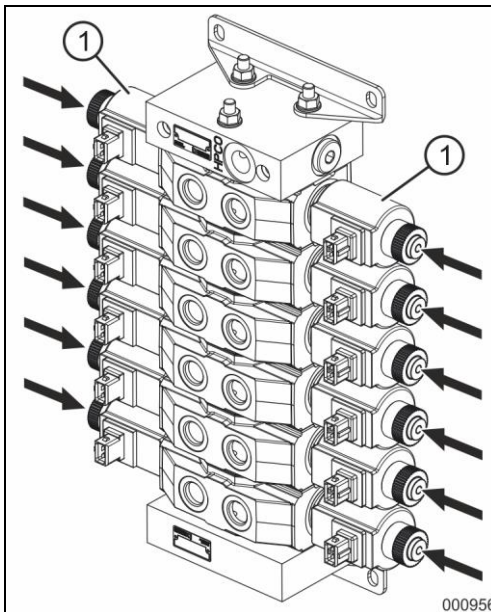

Fig. 94

The solenoids (1) for switching the directional control valves and directional seat valves are actuated directly at the electro-hydraulic control block via the emergency manual operation function.

1. Secure machine against accidental starting and rolling.
2. **ATTENTION** – Risk of damage to the proportional solenoids due to the use of a sharp-edged object. Use a blunt object to push in the armature of the solenoid at the respective switch-over valve to actuate the required hydraulic function.

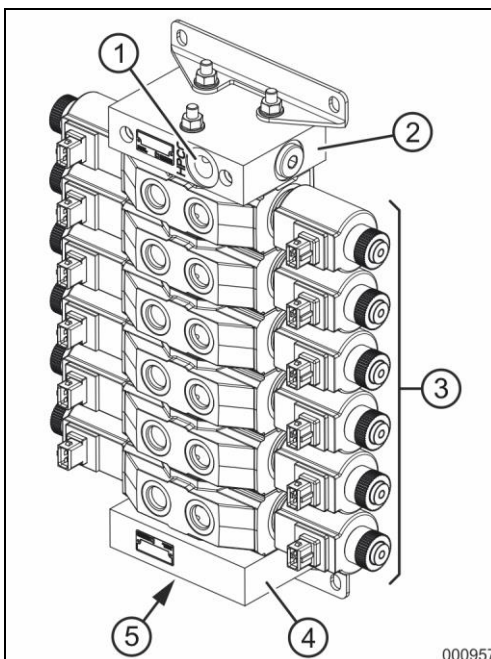
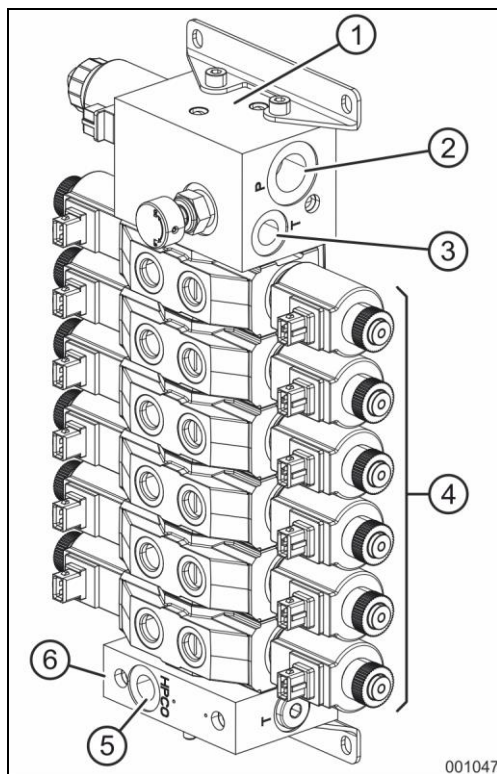

Fig. 95

Control block

- 1 Connection, return line T (R; S)
- 2 End plate
- 3 Directional control valve for e. g. hydraulic cylinder of dosage gate, crossover conveyor drive, hydraulic cylinder of discharge conveyor, hydraulic cylinder of counter-cutters etc.
- 4 Entry plate
- 5 Connection, pressure line P

**Control block with flow regulation valve**

- 1 Control block for variable conveyor speed (optional extra)
- 2 Connection, pressure line P
- 3 Connection, return line T (R; S)
- 4 Directional control valve for e. g. hydraulic cylinder of dosage gate, crossover conveyor drive, hydraulic cylinder of discharge conveyor, hydraulic cylinder of counter-cutters etc.
- 5 Connection, pressure line P
- 6 Entry plate

Fig. 96

001047

10 Service and maintenance

10.1 Safety

As a basic principle, the following is applicable:

- Carry out the specified service and maintenance work on the machine in due time.
- Observe the maintenance intervals for wearing parts.
- Replace damaged or worn parts immediately.
- Secure the tractor against accidental starting and rolling before carrying out service or maintenance work on the machine and climbing onto the machine.
- Wait for the machine to stop completely before entering the hazardous area.
- Existing mechanical, hydraulic, pneumatic and electrical or electronic residual energies may cause accidental machine movements.

Beware of possible residual energies. Warning signs mark the components with residual energies.

- Fix larger assemblies carefully to lifting equipment before replacing them.
- Secure the lifted machine or lifted machine parts against accidental lowering before carrying out service and maintenance work.
- Risk to parts of the body of crushing, shearing, cuts, becoming entangled and drawn in due to powered machine parts if protective devices are open or removed. Always close open protective devices or mount previously removed protective devices before powering the machine.

It is not allowed to open protective devices

- when the machine is powered.
 - as long as the tractor engine is running with the propeller shaft coupled/the hydraulic system connected.
 - when the ignition key is in the tractor and the tractor engine can be accidentally started with the propeller shaft coupled/the hydraulic system connected.
 - when tractor and machine have not been secured against accidental rolling by means of their respective parking brake and the chocks.
- Check screws and nuts for firm seating at regular intervals (approx. every 50 service hours). Retighten loosened screws and nuts.
 - Check loosened screwed connections for firm seating.

- Use appropriate equipment and gloves when replacing working tools with blades.
- Disconnect the generator and battery cable on the tractor and all electrical/electronic plug-in connections before carrying out electrical welding work on the tractor and/or on the attached/hitched machine.
- Protect adjacent parts when carrying out welding, drilling and grinding work and when working with cut-off wheels. This applies in particular to power, hydraulic, brake and supply lines.
 - Cover the lines or remove them at especially critical spots.
- Dispose of oils, greases and filters properly.
- Check all hose pipes with special care for visible defects.
- Observe environmental protection measures when carrying out service and maintenance work on the machine.
- Observe applicable local regulations regarding disposal. This applies also to parts having come into contact with operating media.
- Properly handle and dispose of substances and materials used for cleaning the machine. This applies in particular when working on lubrication systems and devices and when carrying out cleaning work using solvents.
- Load-bearing parts may break due to mechanical work on frame elements. Risk of material damage and serious injuries or even death.

As a basic principle, the following is not allowed:

 - Drilling at the frame or chassis.
 - Boring-up of existing holes at the frame or chassis.
 - Welding on load-bearing parts.
- Exclusively use original spare parts or parts approved by the manufacturer.
- After finishing maintenance work, check the safety and protective devices for proper functioning.
 - Immediately replace missing or defective protective devices.

10.2 Maintenance instructions

- Special know-how is required for carrying out testing and maintenance work, which is not communicated by these operating instructions.
- The maintenance intervals depend on the frequency of use of the machine. The maintenance plan has been tailored to medium axle loads and stress exerted on the brakes.

In case of higher loads and amount of stress, maintenance work must be carried out at respectively shorter intervals. This shall in particular apply to the brakes and chassis.

- In case of doubt, the maintenance intervals, time intervals and service hours specified in the sub-supplier documentation shall prevail.

10.3 Lubricants and operating media

| Lubricant and operating medium | Specification | Manufacturer | Name |
|--------------------------------|----------------------------------|--------------|---|
| Hydraulic oil | ATF according to GM DEXRON® II-D | ARAL | ATF 22 |
| | | AVIA | ATF 86 |
| | | BP | Autran DX II |
| | | Mobil | ATF 220 |
| | | TOTAL | ATX 40 |
| Gear lubricant oil | SAE 80W MIL-L-2105 | AVIA | AVIA Gear Oil MZ 80W |
| | | ARAL | EP 80W |
| | | SHELL | Spirax S3 G 80W |
| | | TOTAL | Transmission Gear 7 80W |
| Grease | KP2N-20 | – | Lithium soap-based multi-purpose grease |













Tab. 21: Lubricants and operating media

10.4 Tightening torques

The tightening torques listed here are reference values. Differing data specified elsewhere in the operating instructions or the enclosed sub-supplier documentation shall always prevail.

- Check screwed connections for firm seating at regular intervals (approx. every 50 service hours).
- Always replace screws and nuts by parts of the same quality.
- Tighten counter nuts with plastic insert and bordered steel counter nuts to approx. 50% of the "dry" value specified in the table.
- Tighten gear or crown nuts to full torque.
- Shear bolts are designed such that they shear off (break) at a certain stress. Only use bolts of equal quality when replacing shear bolts.

10.4.1 Metric standard threads









| Grade and marking of screw heads | | 4.8 | | 8.8 | | 10.9 | | 12.9 | | | | | | | | |
|----------------------------------|-------------|---|---|---|---|---|---|---|---|-------|------|-------|------|-------|------|-------|
| | |  |  |  |  |  |  |  |  | | | | | | | |
| Grade and marking of nuts | |  | |  | |  | |  | | | | | | | | |
| Size | Grade 4.8 | | Grade 8.8 | | Grade 10.9 | | Grade 12.9 | | | | | | | | | |
| | lubricated* | dry ** | lubricated* | dry ** | lubricated* | dry ** | lubricated* | dry ** | | | | | | | | |
| | Nm | lb-ft | Nm | lb-ft | Nm | lb-ft | Nm | lb-ft | Nm | lb-ft | Nm | lb-ft | Nm | lb-ft | Nm | lb-ft |
| M6 | 4.8 | 3.5 | 6 | 4.5 | 9 | 6.5 | 11 | 8.5 | 13 | 9.5 | 17 | 12 | 15 | 11.5 | 19 | 14.5 |
| M8 | 12 | 8.5 | 15 | 11 | 22 | 16 | 28 | 20 | 32 | 24 | 40 | 30 | 37 | 28 | 47 | 35 |
| M10 | 23 | 17 | 29 | 21 | 43 | 32 | 55 | 40 | 63 | 47 | 80 | 60 | 75 | 55 | 95 | 70 |
| M12 | 40 | 29 | 50 | 37 | 75 | 55 | 95 | 70 | 110 | 80 | 140 | 105 | 130 | 95 | 165 | 120 |
| M14 | 63 | 47 | 80 | 60 | 120 | 88 | 150 | 110 | 175 | 130 | 225 | 165 | 205 | 150 | 260 | 190 |
| M16 | 100 | 73 | 125 | 92 | 190 | 140 | 240 | 175 | 275 | 200 | 350 | 255 | 320 | 240 | 400 | 300 |
| M18 | 135 | 100 | 175 | 125 | 260 | 195 | 330 | 250 | 375 | 275 | 475 | 350 | 440 | 325 | 560 | 410 |
| M20 | 190 | 140 | 240 | 180 | 375 | 275 | 475 | 350 | 530 | 400 | 675 | 500 | 625 | 460 | 800 | 580 |
| M22 | 260 | 190 | 330 | 250 | 510 | 375 | 650 | 475 | 725 | 540 | 925 | 675 | 850 | 625 | 1075 | 800 |
| M24 | 330 | 250 | 425 | 310 | 650 | 475 | 825 | 600 | 925 | 675 | 1150 | 850 | 1075 | 800 | 1350 | 1000 |
| M27 | 490 | 360 | 625 | 450 | 950 | 700 | 1200 | 875 | 1350 | 1000 | 1700 | 1250 | 1600 | 1150 | 2000 | 1500 |
| M30 | 675 | 490 | 850 | 625 | 1300 | 950 | 1650 | 1200 | 1850 | 1350 | 2300 | 1700 | 2150 | 1600 | 2700 | 2000 |
| M33 | 900 | 675 | 1150 | 850 | 1750 | 1300 | 2200 | 1650 | 2500 | 1850 | 3150 | 2350 | 2900 | 2150 | 3700 | 2750 |
| M36 | 1150 | 850 | 1450 | 1075 | 2250 | 1650 | 2850 | 2100 | 3200 | 2350 | 4050 | 3000 | 3750 | 2750 | 4750 | 3500 |

Tab. 22: Tightening torques for standard threads

* "Lubricated" means that the screws are treated with a lubricant such as e.g. engine oil, or that phosphatised or oiled screws are used.

** "Dry" means that normal or galvanised screws without any lubrication are used.

10.4.2 Wheel nuts

| | | M14x1.5 | M16x1.5 | M18x1.5 | M20x1.5 | M22x1.5 | | | | | |
|---|--|---------|---------|---------|---------|---------|------|-----|------|-----|------|
| | | [Nm] | | | | | | | | | |
| ADR | | | | | | | | | | | |
| DIN |  | 130+10 | – | 270+20 | – | – | | | | | |
| Ecrous+ Rondelles |  | – | – | 270+20 | 350+30 | 450+60 | | | | | |
| "jumelés" |  | – | – | 270+20 | 350+30 | 450+60 | | | | | |
| "M" |  | – | – | – | 415+35 | 575+75 | | | | | |
| "Bec" |  | – | – | 270+20 | 350+30 | 450+60 | | | | | |
| BPW | | | | | | | | | | | |
| | | – | – | 270±20 | 380±20 | 510±25 | | | | | |
| FAD | | | | | | | | | | | |
| Property class | | 8.8 | 10.9 | 8.8 | 10.9 | 8.8 | 10.9 | 8.8 | 10.9 | 8.8 | 10.9 |
| Spherical collar nut, conical nut, spherical collar screw |  | 160 | 220 | 230 | 330 | 330 | 460 | 490 | 630 | 630 | 740 |
| Flat collar nut with spherical washer |  | 120 | 170 | 190 | 260 | 270 | 360 | 360 | 450 | 460 | 550 |
| Flat nut with pivotable flat washer |  | – | – | – | – | 260 | 360 | 350 | 500 | 450 | 650 |

Tab. 23: Tightening torques for wheel nuts

10.5 Maintenance and lubrication plan

Scheduled service and maintenance of the machine is an important prerequisite for reliable functioning. Insufficient maintenance may provoke malfunctions or damage causing downtimes and repair costs.

Due maintenance work is specified in the maintenance plan and lubrication plan and listed according to the intervals.

The minimum qualification required for the staff to carry out the respective work is specified in the column "Performer" and in front of the description of the maintenance activity.

If increased wear is detected during regular checks, reduce the required maintenance intervals according to wear.

10.5.1 Maintenance plan – Machine

| Before each start-up | | |
|---|------------------|------------|
| Maintenance work | Performer | see |
| Hydraulic hose pipes – Visual checks for defects and damage | Operator | ▶ page 207 |

| After the first 5 service hours | | |
|---|------------------|--------------------------|
| Maintenance work | Performer | see |
| Switchgear – Check oil level * | Operator | ▶ page 184 |
| Power shift gearbox – Check oil level * | Operator | ▶ page 185 ▶ page 188 |

* after commissioning / after a change of the gear lubricant oil

| After the first 10 service hours | | |
|---|------------------|------------|
| Maintenance work | Performer | see |
| Mixer gearbox – Check oil level * | Operator | ▶ page 182 |
| Hydraulic system – Check all components for tightness | Qualified staff | ▶ page 204 |

* after commissioning / after a change of the gear lubricant oil

| Daily | | |
|---|------------------|------------|
| Maintenance work | Performer | see |
| Hydraulic system of forced steering axle system – Check oil pressure | Operator | ▶ page 209 |
| Tyres – Check tyre pressure and carry out visual check for defects | Operator | ▶ page 211 |
| Crossover conveyor, discharge conveyor, conveyor extension – Check tension and carry out visual check for defects | Operator | ▶ page 201 |
| Compressed-air brake system – Drain compressed-air reservoir | Operator | ▶ page 213 |
| Oil cooler – Check for deposits, clean fins | Operator | ▶ page 180 |

| Every 50 service hours | | |
|--|------------------|------------|
| Maintenance work | Performer | see |
| Crossover conveyor, discharge conveyor, conveyor extension – Lubricate flange bearing | Operator | ▶ page 174 |
| Hydraulic system – Check all components for tightness | Qualified staff | ▶ page 204 |
| Compressed-air brake system – Check in-line filter | Qualified staff | ▶ page 214 |

| Every 3 months | | |
|--|------------------|------------|
| Maintenance work | Performer | see |
| Compressed-air brake system – Clean in-line filter | Qualified staff | ▶ page 214 |

| Every 200 service hours | | |
|---|---------------------|------------|
| Maintenance work | Performer | see |
| Brake system – Check for proper functioning | Authorised workshop | ▶ page 215 |

| After 1000 service hours for the first time, then every 2000 service hours | | |
|---|---------------------|--------------------------|
| Maintenance work | Performer | see |
| Mixer gearbox – Change oil | Authorised workshop | ▶ page 182 |
| Switchgear – Change oil | Authorised workshop | ▶ page 184 |
| Power shift gearbox – Change oil | Authorised workshop | ▶ page 185 ▶ page 188 |

| If required/worn | | |
|--|---------------------|------------|
| Maintenance work | Performer | see |
| Shear bolt coupling – Replace shear bolt | Qualified staff | ▶ page 191 |
| Dosage gate – Check gap size | Qualified staff | ▶ page 192 |
| Mixing auger – Replace cutting knives | Authorised workshop | ▶ page 194 |
| Mixing auger – Grind cutting knives | Authorised workshop | ▶ page 198 |
| Magnetic system – Clean magnets | Operator | ▶ page 199 |
| Crossover conveyor, discharge conveyor, conveyor extension – Tighten and adjust conveyor belt | Qualified staff | ▶ page 201 |
| Crossover conveyor, discharge conveyor, conveyor extension – Clean driving rollers, carrying rollers and pulleys | Qualified staff | ▶ page 201 |
| Mechanical Bowden cable operation – Replace Bowden cable | Qualified staff | ▶ page 202 |
| Remote control cable – Replace adapter | Qualified staff | ▶ page 203 |
| Tyres – Change | Qualified staff | ▶ page 212 |
| Compressed-air brake system – Set | Authorised workshop | ▶ page 215 |
| Compressed-air brake system – Replace brake linings | Authorised workshop | ▶ page 215 |
| Hydraulic brake system – Set | Authorised workshop | ▶ page 216 |
| Hydraulic brake system – Replace brake linings | Authorised workshop | ▶ page 216 |

10.5.2 Maintenance plan – Chassis

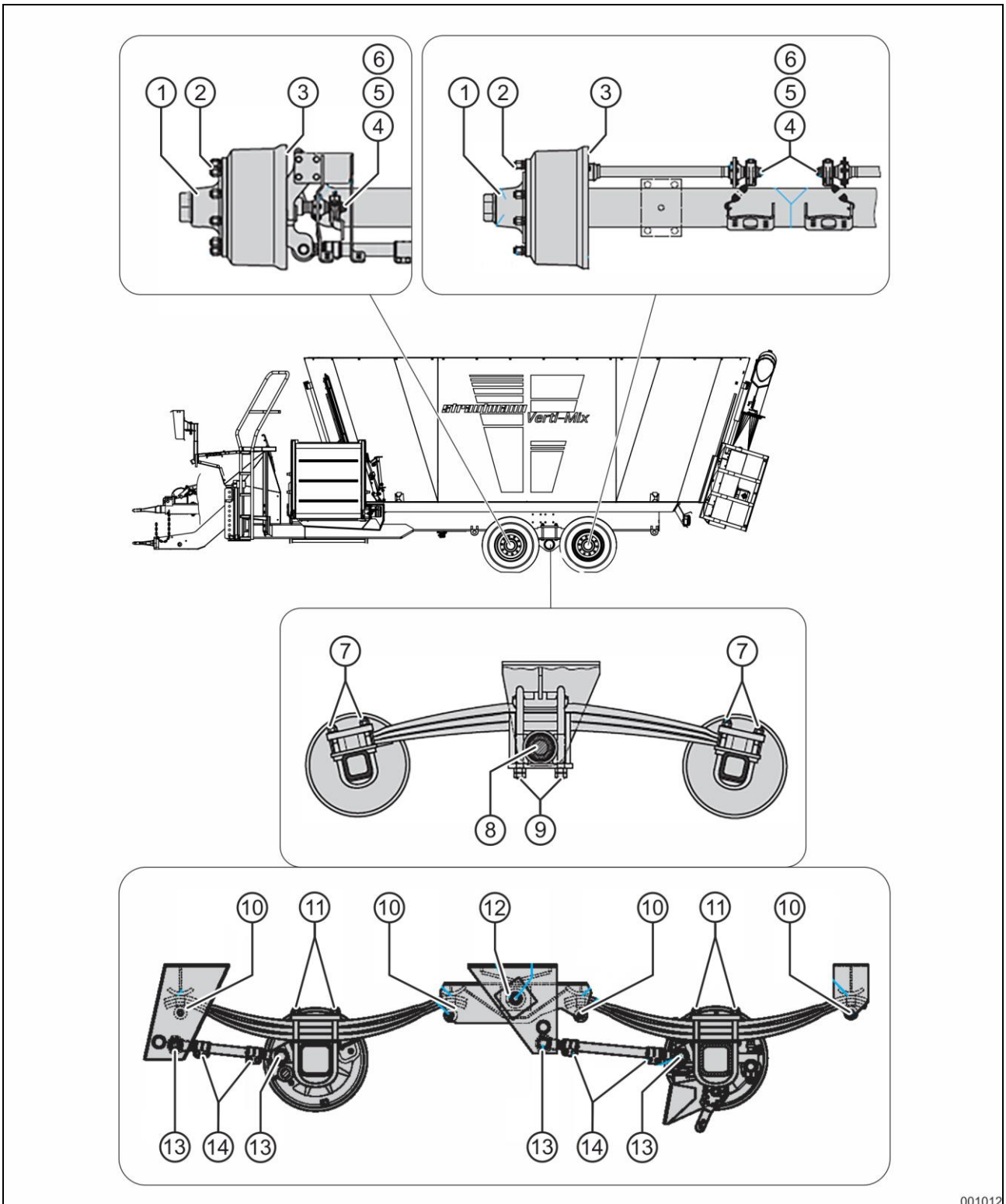

001012

Fig. 97

| Before each start-up | | |
|---|------------------|------------|
| Maintenance work | Performer | see |
| Check wheel nuts for firm seating ¹⁾ | Qualified staff | Pos. (2) |

| After first journey with loaded material | | |
|---|---------------------|------------|
| Maintenance work | Performer | see |
| Check wheel nuts for firm seating | Qualified staff | Pos. (2) |
| Check spring clamps at the supporting axle for firm seating | Authorised workshop | Pos. (9) |
| Check bearing bolt at the spring tension casings for firm seating | Authorised workshop | Pos. (8) |
| Check counter nuts of axle steering mechanisms for firm seating | Authorised workshop | Pos. (13) |
| Check axle connection for firm seating | Authorised workshop | Pos. (11) |

| Every 200 service hours | | |
|--|---------------------|------------|
| Maintenance work | Performer | see |
| Check play of wheel hub bearing | Authorised workshop | Pos. (1) |
| Check brake linings for damage and wear | Authorised workshop | Pos. (3) |
| Check brake setting at brake lever | Authorised workshop | Pos. (4) |
| Check brake setting at manual slack adjuster | Authorised workshop | Pos. (5) |

| Every 500 service hours or every 6 months | | |
|--|---------------------|------------|
| Maintenance work | Performer | see |
| Visually check all components for damage and wear | Operator | – |
| Check wheel nuts for firm seating | Qualified staff | Pos. (2) |
| Check spring clamps at the supporting axle for firm seating | Authorised workshop | Pos. (9) |
| Check axle connection at the spring tension casings for firm seating | Authorised workshop | Pos. (7) |
| Check threaded bolt of oscillating arm bearing for firm seating | Authorised workshop | Pos. (12) |
| Check counter nuts of axle steering mechanisms for firm seating | Authorised workshop | Pos. (13) |
| Check axle connection for firm seating | Authorised workshop | Pos. (11) |
| Check fastening screws of rubber rollers and slide elements for firm seating | Authorised workshop | Pos. (10) |

| | | |
|---|---------------------|----------|
| Check brake setting at automatic slack adjuster | Authorised workshop | Pos. (6) |
| Check automatic slack adjuster for proper functioning ²⁾ | Qualified staff | Pos. (6) |

¹⁾ Also after each wheel change

²⁾ Also after each change of brake linings

10.5.3 Lubrication plan – Machine

NOTE

Observe the enclosed sub-supplier documentation for lubrication of the propeller shaft(s).

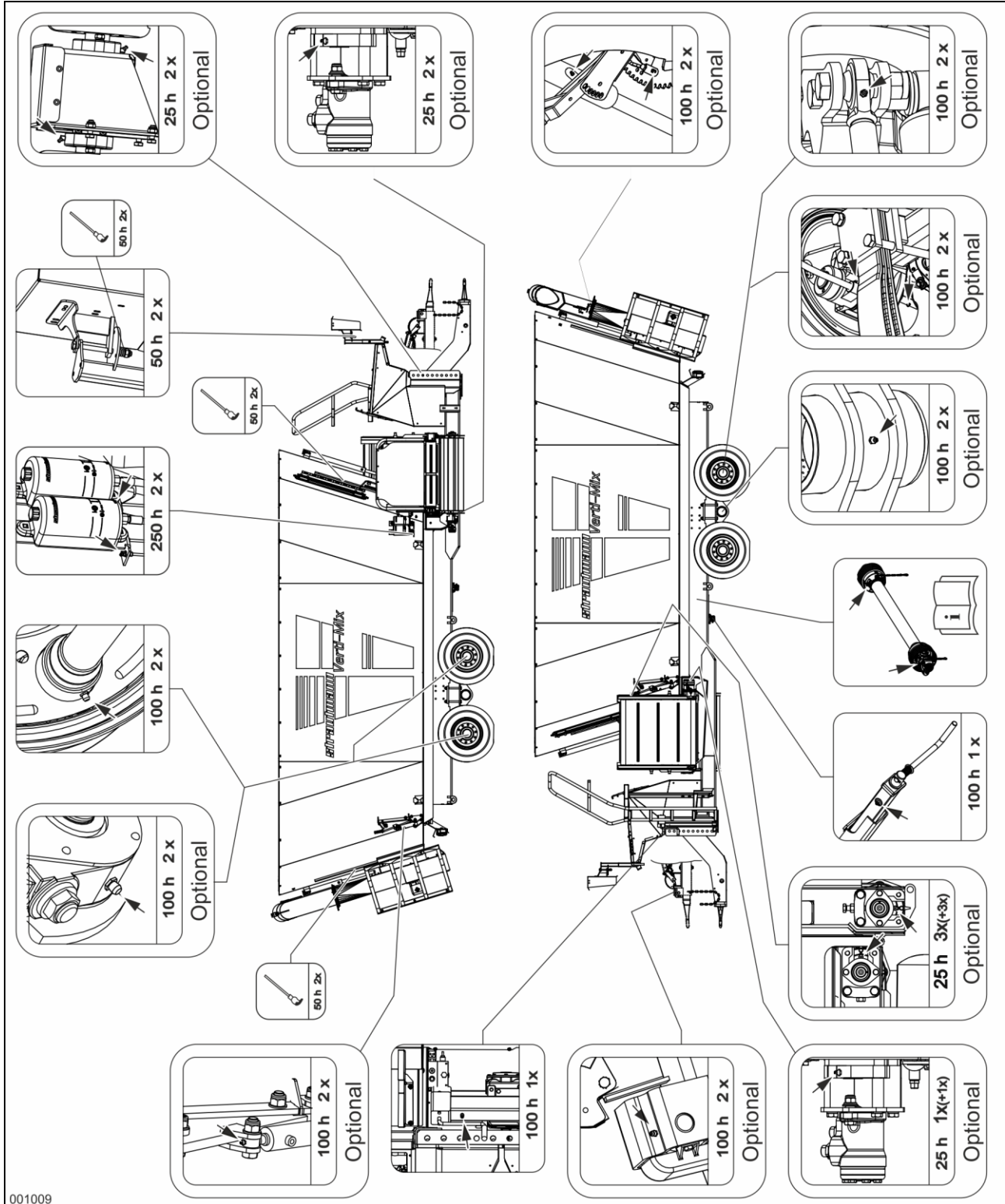

001009

Fig. 98

10.5.4 Lubrication plan – Chassis

NOTE

Relubricate all lubrication points after cleaning the machine by means of a pressure washer.

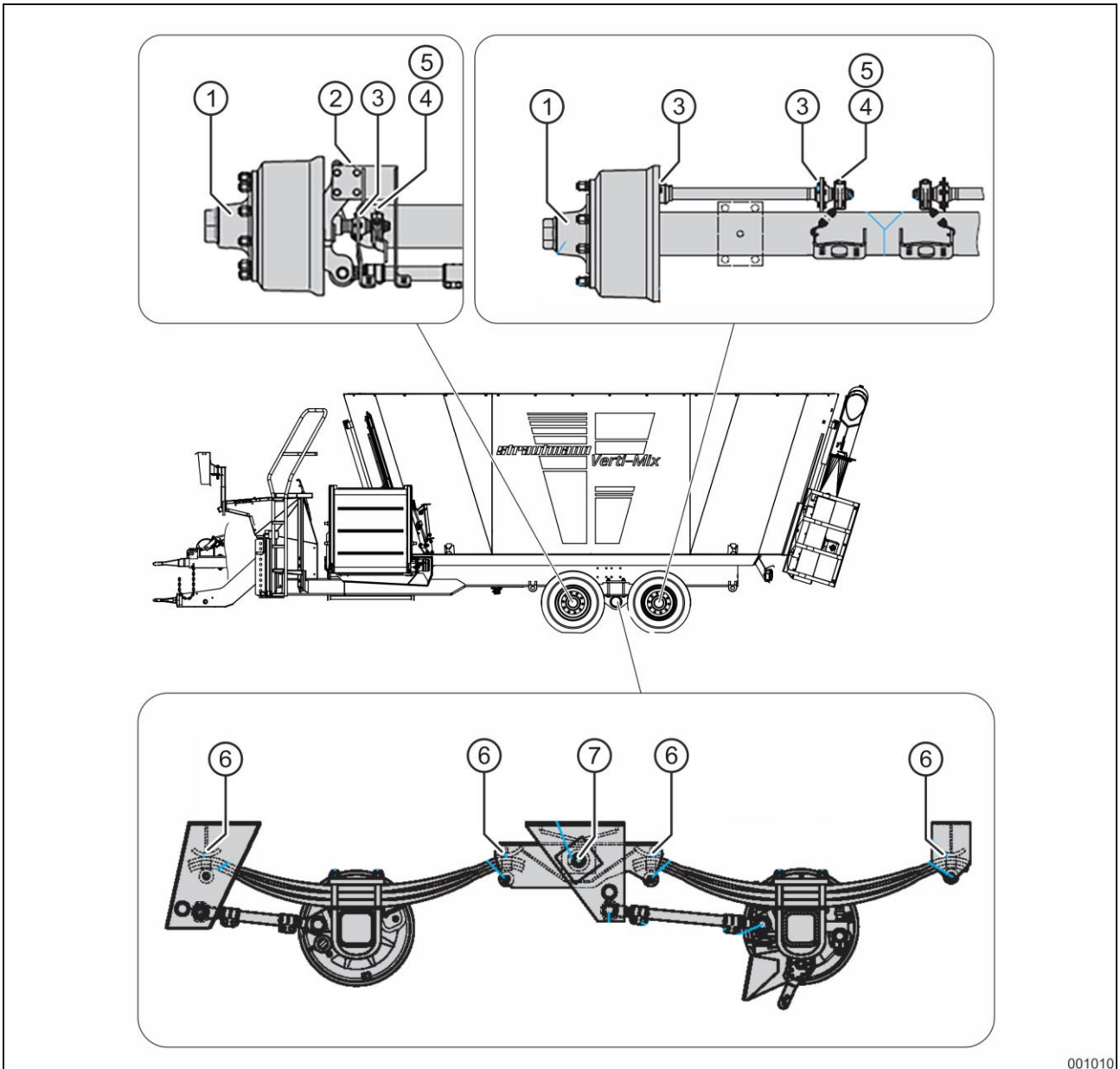

001010

Fig. 99

| Before each start-up | | |
|-----------------------------|------------------|------------|
| Lubricate | Performer | see |
| Brake shaft bearing | Operator | Pos. (3) |

| After first journey with loaded material | | |
|---|------------------|------------|
| Lubricate | Performer | see |
| Oscillating arm bearing (not applicable with rubber-steel bushings) | Operator | Pos. (7) |
| Slide elements/slide ends of springs (slightly grease) | Operator | Pos. (6) |

| Every 40 service hours | | |
|-----------------------------------|------------------|----------------------------|
| Lubricate | Performer | see |
| Knuckle arm bearing ¹⁾ | Operator | Pos. (2) and ▶ page 218 |

| Every 100 service hours | | |
|---|------------------|------------|
| Lubricate | Performer | see |
| Oscillating arm bearing (not applicable with rubber-steel bushings) | Operator | Pos. (7) |
| Slide elements/slide ends of springs (slightly grease) | Operator | Pos. (6) |

| Every 200 service hours | | |
|-----------------------------------|------------------|----------------------------|
| Lubricate | Performer | see |
| Brake shaft bearing ¹⁾ | Operator | Pos. (3) and ▶ page 217 |

| Every 500 service hours or every 6 months | | |
|--|------------------|----------------------------|
| Lubricate | Performer | see |
| Manual slack adjuster ¹⁾ | Operator | Pos. (4) and ▶ page 217 |
| Automatic slack adjuster ^{1) 2)} | Operator | Pos. (5) |

| Every 1000 service hours or once a year | | |
|--|---------------------|------------|
| Change grease | Performer | see |
| Have grease of wheel hub bearing changed | Authorised workshop | Pos. (4) |

¹⁾ Lubricating nipples possibly grouped at another point

²⁾ Also after each change of brake linings

10.6 Enter the mixing container

As a basic principle, the following is applicable:

- Park the machine on firm, even ground.
- Safely park the machine and secure it against accidental rolling.
- Secure lifted machine parts against accidental lowering.
- Never enter the mixing container through the discharge opening as long as the engine is running and the dosage gate has not been secured against accidental lowering.
- Risk of crushing when opening and closing the dosage gate.
- Keep people and animals away from the hazardous area.
- Only carry out work in an empty mixing container which is as clean and dry as possible.
- Wear personal protective equipment.
 - Non-slip safety footwear
 - Cut-proof protective gloves
- Risk of tripping. Pay particular attention to the scraper(s) of the mixing auger(s) near the bottom.

WARNING

Falling from the top edge of the mixing container

Risk of serious injuries or even death when falling into the mixing container.

It is not allowed

- to stay above the mixing container.
 - to bend over the mixing container.
 - to enter the mixing container from above.
-

WARNING

Implants being affected by electromagnetic fields

Risk of harm to health or even death to persons with electronic implants such as pacemakers due to magnetic fields.

- Keep an adequate safety distance from magnets if you wear an electronic implant.
-

⚠ CAUTION
Sharp-edged cutting knives

Risk of cuts.

- Wear cut-resistant protective gloves.
- Cover the cutting knives by means of an edge protector.

Operative staff:

- Authorised workshop
Only authorised qualified staff is allowed to carry out work in the mixing container.

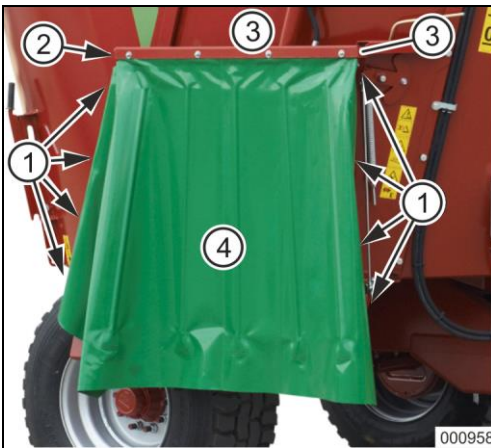

Fig. 100

1. Completely open the dosage gate of the discharge opening through which you want to enter the mixing container.
2. Secure tractor and machine against accidental starting and rolling.
3. Strip the propeller shaft off the tractor's p.t.o. shaft to enable manual rotation of the mixing auger via the propeller shaft if necessary.
4. **⚠ CAUTION** – Risk of cuts due to cutting knives. Rotate the mixing auger such that the cutting knives are directed away from the discharge opening.
5. Unscrew the screwed connections (1) between protective cover (4) and mixing container (3).
6. Remove the screwed connection (2) of the swivel pin and take off the protective cover (4).
7. Enter and leave the mixing container carefully through the discharge opening or the crossover conveyor and the discharge opening.
8. Properly fix the protective cover (4) again at the mixing container after finishing all necessary work in the mixing container.

10.7 Clean machine

- Regularly and thoroughly clean the machine. Dirt binds humidity thus causing rust formation.
- Lubricate the machine after cleaning, especially after cleaning by means of a pressure washer / steam blaster or fat-dissolving agents.

WARNING

Toxic and flammable detergents

Risk of poisoning and risk of fire due to the use of inadmissible detergents.

- Never use fuels, benzene, paraffin or mineral oils as detergents.
- Observe the data sheets.

ATTENTION

Damage to components or the electronic system

When using a pressure washer / steam blaster for cleaning, observe:

- the operating instructions of the pressure washer/steam blaster manufacturer.
- Keep to the maximum admissible injection pressure of 80 bar.
- Do not exceed the water temperature of 60°C.
- Do not clean electronic components.
- Do not clean chromium-plated components.
- Do not aim the jet directly at the following components:
 - Lubrication points and bearings
 - Hydraulic components
 - Seals
- Keep a minimum distance of 30 cm between the cleaning nozzle and the machine.
- Never aim the cleaning nozzle jet at the components at right angles. The spray angle must at least be 25°.
- Do not use any chemical additives.



- Carry out cleaning work at a washing area provided for this purpose.
- Observe the environmental protection rules.
- Dispose of used detergents and empty containers in accordance with the environmental regulations.

10.8 Clean oil cooler

Operative staff:

- Operator

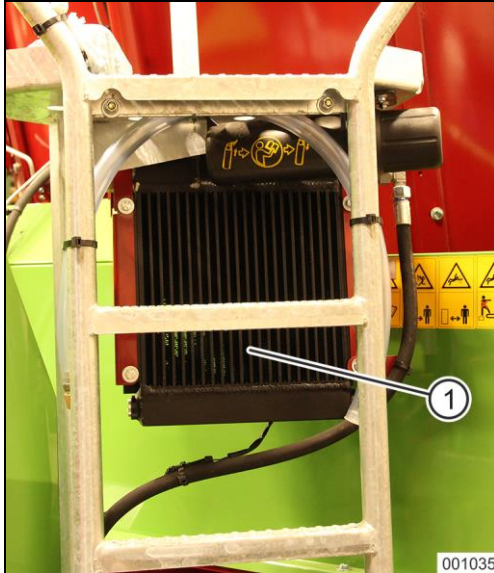

Fig. 101

⚠ WARNING

Eye injuries

Risk of injury when using compressed air. Risk of eye injuries due to whirled-up particles when blowing out by means of compressed air.

- Wear protective goggles.
- Do not aim the air jet at people.

1. Visually check the fins (1) of the oil cooler for contamination and deposits.
2. Use compressed air to blow out the fins.

10.9 Lubricate machine

- Observe the specified intervals and lubricants according to the lubrication plan, ► see page 174. Observe the enclosed sub-supplier documentation where applicable.
- Remove the dirt from the lubricating nipples before carrying out lubrication work.
- Only use lithium-saponified multi-purpose grease.

ATTENTION

Damage to components

Damage to bearings, seals etc. may occur if the lubricating pressure is excessive and the grease gun used is not equipped with a protective device.

- Do not exceed the maximum lubricating pressure of 250 bar.



- Use environmentally friendly, biodegradable oils and greases where lubricants may penetrate the fodder or the ground.
- Remove excess grease at the lubricating nipple immediately.
- Observe the environmental protection rules.

10.10 Gear lubricant oil

Change the oil when warmed up to operating temperature (30-40 °C). The flowability of the gear lubricant oil is at its optimum at operating temperature.

The optimum oil level can be determined at an oil temperature of 0-20°C.

ATTENTION

Damage to the machine due to lack of oil

- Always ensure a sufficient oil level.

CAUTION

Risk of slipping due to leaking oil

Risk of slipping and falling to people due to leaking oil during topping-up of oil or oil change.

- Immediately remove oil spills by means of binding agents.



Dispose of used oil properly.

Change gear lubricant oil:

- for the first time after 1000 service hours
- then every 2000 service hours.

10.10.1 Mixer gearbox

Check oil level

Operative staff:

- Operator

NOTE

The mixer gearbox is initially filled with AVIA MZ 80 W.

Check the oil level before starting the mixing process, as the oil heats up during the mixing process thus causing the level in the compensating reservoir to rise.

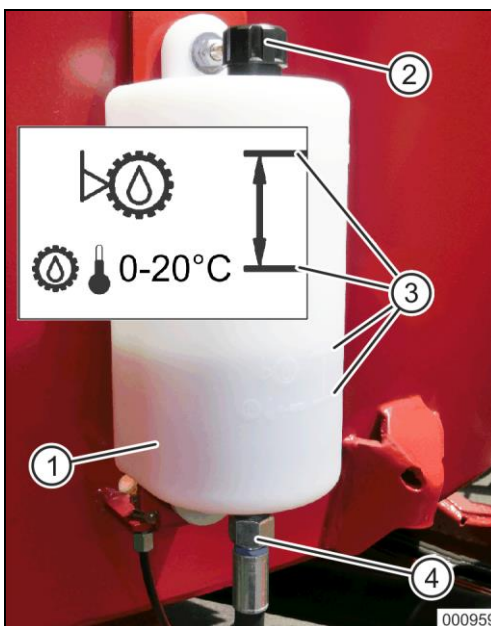

Fig. 102

1. Check the oil level in the compensating reservoir (1).
The oil level must be visible between the two markings (3).
2. Top up gear lubricant oil if necessary.
 - Loosen the vent screw (2).
 - Top up gear lubricant oil.
 - Tighten the vent screw (2).

Change oil

Operative staff:

- Authorised workshop

1. Park the machine on even ground.
2. Switch the machine off and secure it against rolling.
3. Place the drip tray beneath the compensating reservoir (1).
 - Capacity approx. 30 litres
4. Loosen the vent screw (2).
5. Unscrew the hose pipe (4).
→ The gear lubricant oil drains off into the drip tray.
6. Screw the hose pipe (4) on.

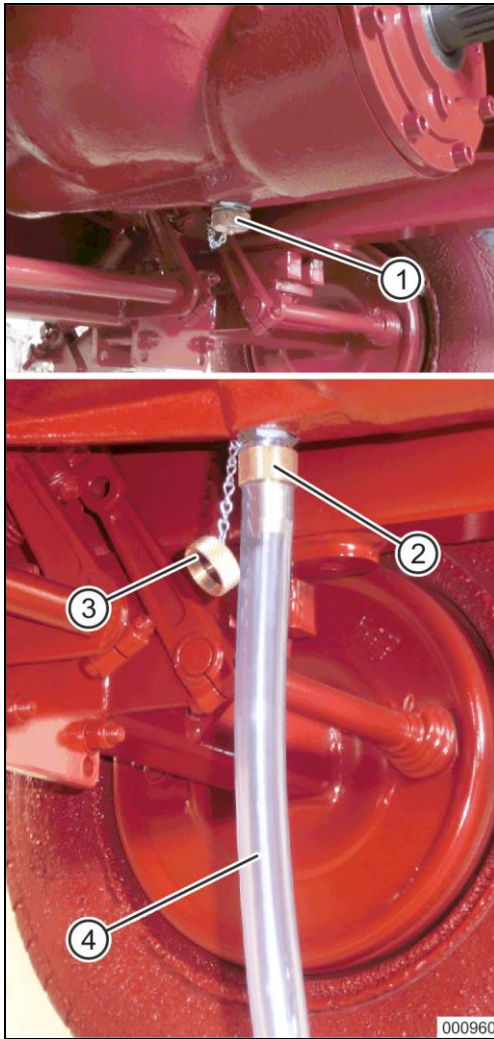

Fig. 103

7. Place the drip tray beneath the drain valve (1).
 8. Hang the oil drain hose (4) into the drip tray.
 9. Unscrew the cap (3).
 10. Use the union nut (2) to screw the oil drain hose (4) onto the drain valve.
- The drain valve opens and the gear lubricant oil drains off into the drip tray.
11. Wait until no more oil comes out of the oil drain hose.
 12. Connect the filling pump to the oil drain hose.
 13. Fill gear lubricant oil through the filling pump into the mixer gearbox until the gear lubricant oil is flowing in the compensating reservoir and the oil level is visible between the two markings (Fig. 102/3).

NOTE

Fill the gear lubricant oil slowly into the mixer gearbox, in order to avoid formation of bubbles, which would prevent filling-in of a sufficient quantity of gear lubricant oil.

14. Unscrew the oil drain hose from the drain valve.
15. Disconnect the filling pump from the oil drain hose.
16. Screw the cap (3) onto the drain valve.
17. Screw on the vent screw (83/2).
18. Carry out a test run for several minutes.
19. Check oil level.
20. Top up gear lubricant oil through the vent opening.

NOTE

Check the oil level in the mixer gearbox several times during the first 10 service hours after changing the gear lubricant oil.



Dispose of used oil properly.

10.10.2 Switchgear

Check oil level

Operative staff:

- Operator

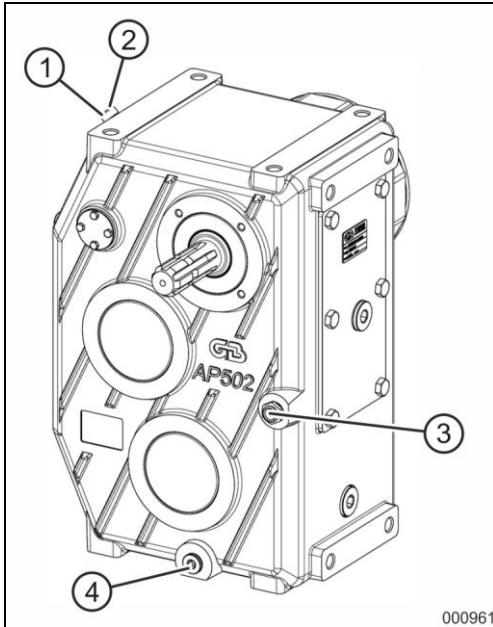

Fig. 104

1. Unscrew the inspection plug (3).
The oil must be visible up to the level of the threaded hole.
2. Top up gear lubricant oil if necessary.
 - Loosen the vent screw (1).
 - Top up gear lubricant oil through the filler neck (2).
 - Screw the vent screw (1) in.
3. Screw the inspection plug (3) in.

Change oil

Operative staff:

- Authorised workshop

1. Park the machine on even ground.
2. Switch the machine off and secure it against rolling.
3. Place a drip tray beneath the gearbox.
 - Capacity approx. 15 litres
4. Unscrew the oil drain plug (4) and the vent screw (1).
→ The gear lubricant oil drains off into the drip tray.
5. Wait until no more oil comes out of the oil drain opening.
6. Screw the oil drain plug (4) in.
 - Apply sealant.
 - Tighten the oil drain plug.
7. Unscrew the inspection plug (3).
8. Fill in 13 litres of gear lubricant oil through the filler neck (2) until the oil is visible at the level of the threaded hole.
9. Screw the inspection plug (3) in.
10. Clean and screw in the vent screw (1).
11. Check the oil level after 5 service hours.



Dispose of used oil properly.

10.10.3 Power shift gearbox (2-gear)

Check oil level

Operative staff:

- Operator

NOTE

The following figures are exemplary. The oil cooler is not, as illustrated here, mounted above the gearbox, but at the ladder.

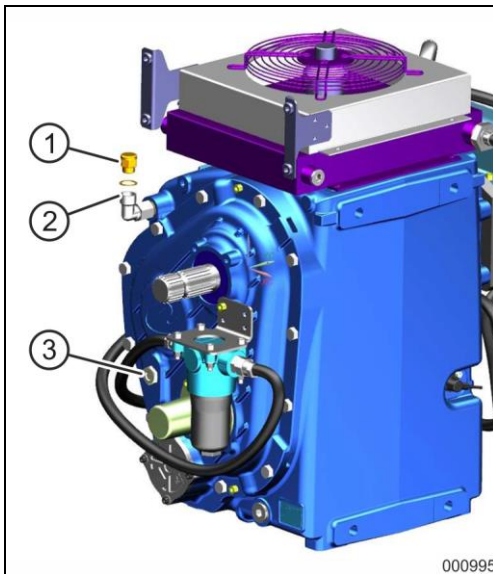

Fig. 105

1. Unscrew the inspection plug (3).
The oil must be visible up to the level of the threaded hole.
2. Top up gear lubricant oil if necessary.
 - Loosen the vent screw (1).
 - Top up gear lubricant oil through the elbow joint (2).
 - Screw the vent screw (1) in.
3. Screw the inspection plug (3) in.

Change oil and replace oil filter

Operative staff:

- Authorised workshop

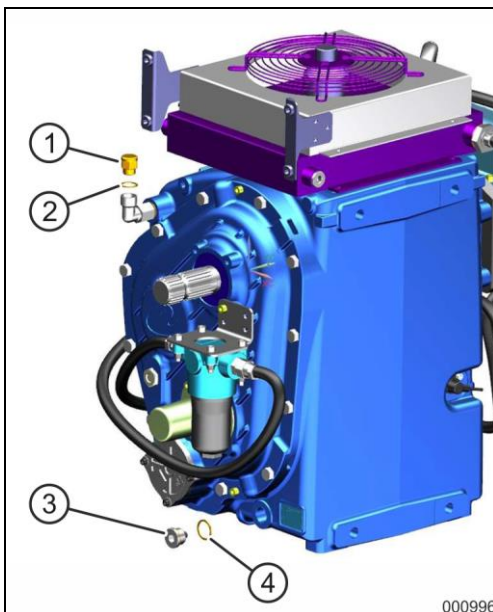

Fig. 106

1. Park the machine on even ground.
2. Switch the machine off and secure it against rolling.
3. Place a drip tray beneath the drain opening.
 - Capacity approx. 25 litres
4. Loosen the vent screw (1) and remove the sealing ring (2).
5. Unscrew the oil drain plug (1) and remove the sealing ring (2).
→ The gear lubricant oil drains off into the drip tray.
6. Wait until no more oil comes out of the oil drain opening.

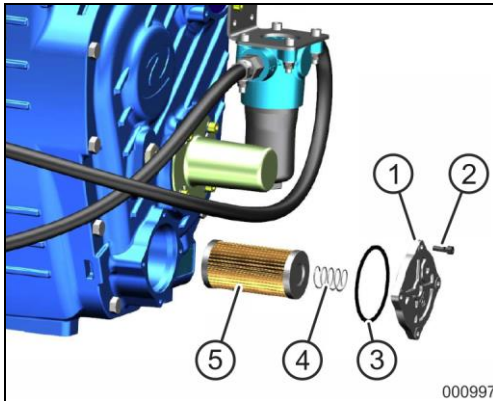

Fig. 107

7. Loosen the screws (2).
8. Remove the cover (1).
9. Remove spring (4) and oil filter (5).
10. Remove the O-ring (3).

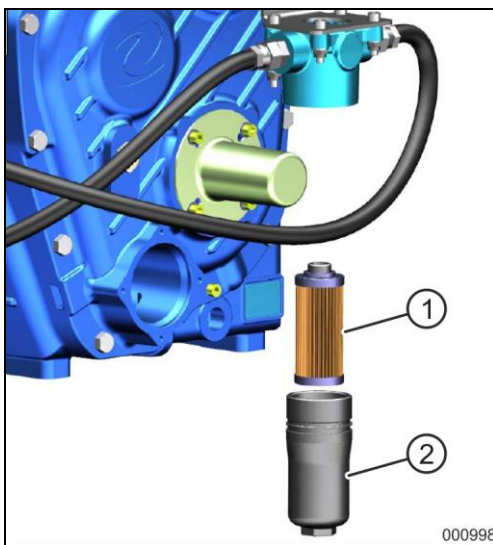

Fig. 108

11. Unscrew the filter casing (2).
12. Remove the oil filter (1).



Dispose of used oil and oil filter properly.

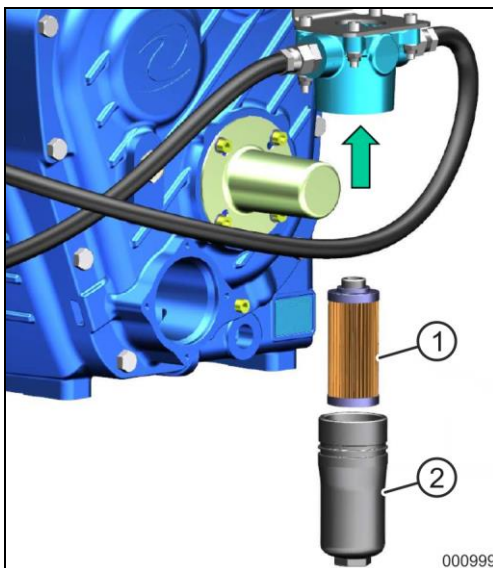

Fig. 109

13. Insert new oil filter (1) into the retainer.
14. Clean the thread of the filter casing (2).
 - Apply lithium grease detergent Greasil 500 to the thread.
15. Screw on the filter casing (2).
 - Tightening torque: 30 - 50 Nm

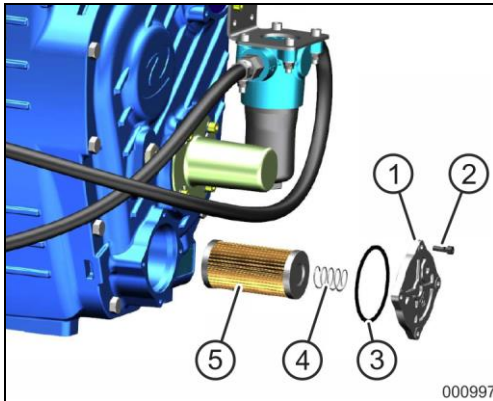

Fig. 110

16. Insert new oil filter (5) into the retainer.
17. Lubricate the O-ring (3) and insert it into the cover (1).
18. Apply Loctite 243 to the threads of the screws (2).
19. Insert the spring (4).
20. Use the screws (2) to screw on the cover (1).
 - Tightening torque: 10 - 13 Nm

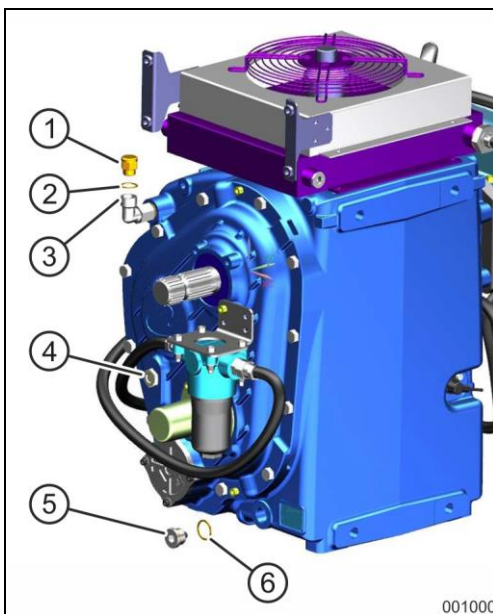

Fig. 111

21. Clean the oil drain plug (5) and screw in together with the sealing ring (6).
 - Tightening torque: 30 - 35 Nm
22. Fill in 25 litres of gear lubricant oil through the elbow joint (3). Use oil with the following specification:
 - Normal ambient temperature: SAE 10-W30, API GI-4, Vollsynthetik PAO
 - Low ambient temperature: SHELL Spirax S3 TLV
23. Check oil level.
 - The oil must be visible up to the level of the threaded hole of the inspection plug (4).
24. Screw the inspection plug (4) in.
25. Clean the vent screw (1) and screw in together with the sealing ring (2).
 - Tightening torque: 30 - 35 Nm
26. Check the oil level after the first operation cycle and top up if necessary.

10.10.4 Power shift gearbox (3-gear)

Check oil level

Operative staff:

- Operator

NOTE

The following figures are exemplary. The oil cooler is not, as illustrated here, mounted above the gearbox, but at the ladder.

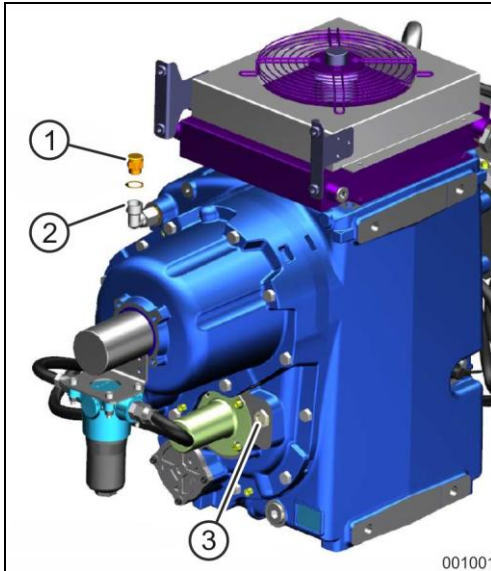

Fig. 112

1. Unscrew the inspection plug (3).
The oil must be visible up to the level of the threaded hole.
2. Top up gear lubricant oil if necessary.
 - Loosen the vent screw (1).
 - Top up gear lubricant oil through the elbow joint (2).
 - Screw the vent screw (1) in.
3. Screw the inspection plug (3) in.

Change oil and replace oil filter

Operative staff:

- Authorised workshop

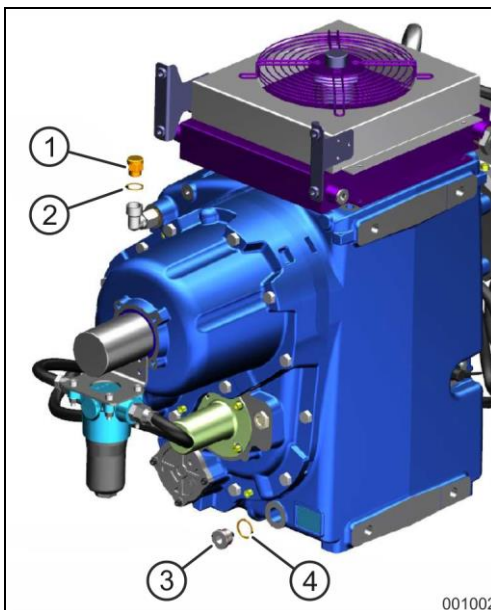

Fig. 113

1. Park the machine on even ground.
2. Switch the machine off and secure it against rolling.
3. Place a drip tray beneath the drain opening.
 - Capacity approx. 28 litres
4. Loosen the vent screw (1) and remove the sealing ring (2).
5. Unscrew the oil drain plug (1) and remove the sealing ring (2).
→ The gear lubricant oil drains off into the drip tray.
6. Wait until no more oil comes out of the oil drain opening.

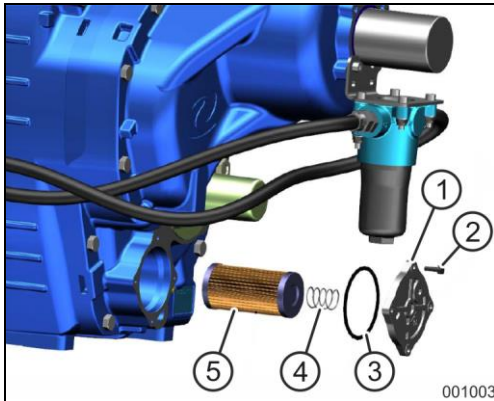

Fig. 114

7. Loosen the screws (2).
8. Remove the cover (1).
9. Remove spring (4) and oil filter (5).
10. Remove the O-ring (3).

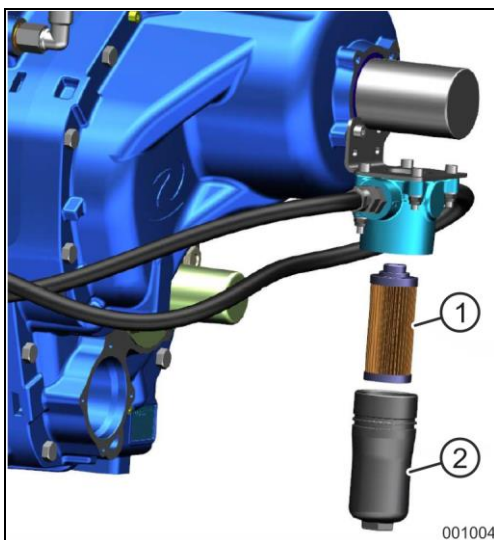

Fig. 115

11. Unscrew the filter casing (2).
12. Remove the oil filter (1).



Dispose of used oil and oil filter properly.

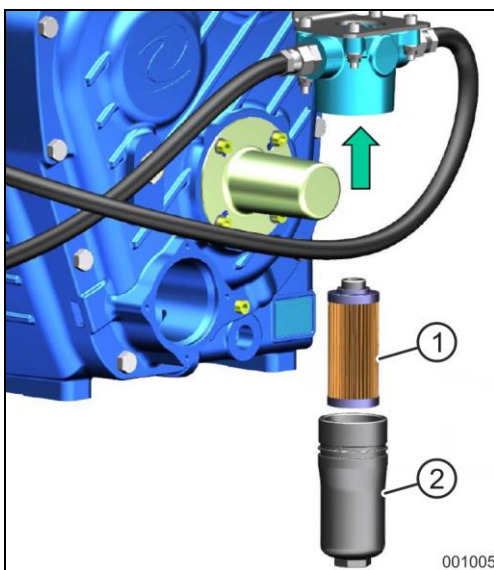

Fig. 116

13. Insert new oil filter (1) into the retainer.
14. Clean the thread of the filter casing (2).
 - Apply lithium grease detergent Greasil 500 to the thread.
15. Screw on the filter casing (2).
 - Tightening torque: 30 - 50 Nm

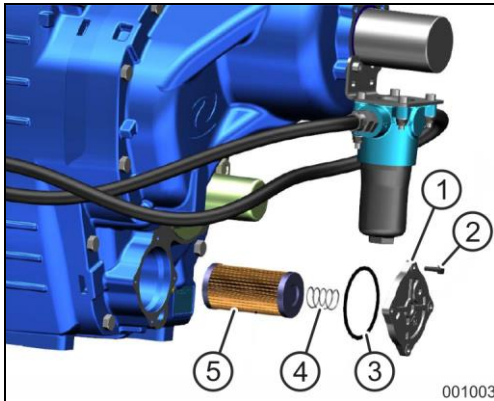

Fig. 117

16. Insert new oil filter (5) into the retainer.
17. Lubricate the O-ring (3) and insert it into the cover (1).
18. Apply Loctite 243 to the threads of the screws (2).
19. Insert the spring (4).
20. Use the screws (2) to screw on the cover (1).
 - Tightening torque: 10 - 13 Nm

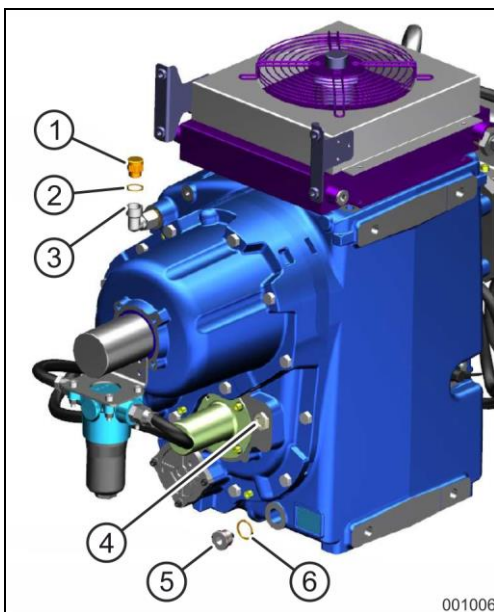

Fig. 118

21. Clean the oil drain plug (5) and screw in together with the sealing ring (6).
 - Tightening torque: 30 - 35 Nm
22. Fill in 28 litres of gear lubricant oil through the elbow joint (3). Use oil with the following specification:
 - Normal ambient temperature: SAE 10-W30, API GI-4, Vollsynthetik PAO
 - Low ambient temperature: SHELL Spirax S3 TLV
23. Check oil level.
 - The oil must be visible up to the level of the threaded hole of the inspection plug (4).
24. Screw the inspection plug (4) in.
25. Clean the vent screw (1) and screw in together with the sealing ring (2).
 - Tightening torque: 30 - 35 Nm
26. Check oil level after the first operation cycle and top up if necessary.

10.11 Replace shear bolts of shear bolt coupling

Operative staff:

- Qualified staff

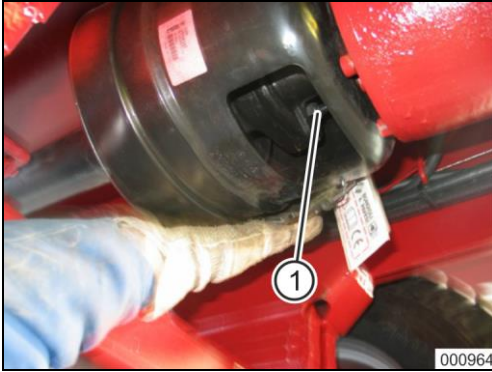

Fig. 119

1. Secure tractor and machine against accidental starting and rolling
2. Eliminate the cause of the overload (e.g. clogging of discharge opening), ► see section 8.4.2, page 142.
3. Strip the propeller shaft (2) off the p.t.o. shaft of the tractor.
4. Open the fitting apertures at the protective device. Observe the enclosed operating instructions for the propeller shaft.
5. Remove the residues of the shear bolt (1).
6. Rotate the power train such that the boreholes of the coupling halves (3) and (4) face each other.
7. Replace the shear bolt (1) by a bolt M10 x 50 8.8.
8. Close the fitting aperture.
9. Couple the propeller shaft (2).

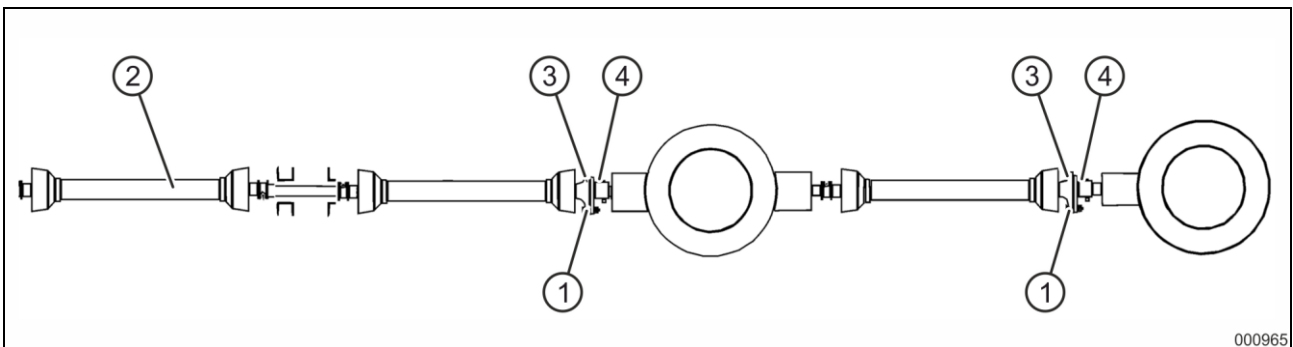

Fig. 120

10.12 Dosage gate – Check gap size

Operative staff:

- Qualified staff

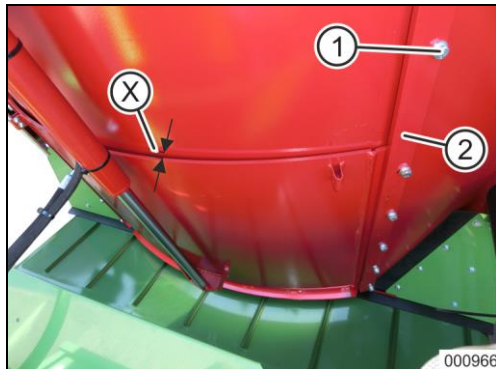

Fig. 121

1. Lower the dosage gate completely.
2. Secure machine against accidental starting and rolling.
3. Measure the distance X between the dosage gate and the mixing container.
 - Required distance = 5 mm
4. Adjust the distance X if necessary:
 - Loosen the screws (1) at the L straps (2).
 - Move the L straps (2) in the oblong holes, such that the distance X is approx. 5 mm.
 - Retighten the screws (1).

10.13 Mixing auger – Cutting knives

Blunt cutting knives require a higher mixing auger power. Therefore, grind the cutting knives as required.

10.13.1 Check cutting knives

Operative staff:

- Operator
Only an authorised workshop is allowed to carry out work in the mixing container.
-

WARNING

Falling from the top edge of the mixing container

Risk of serious injuries or even death when falling into the mixing container.

It is not allowed

- to stay above the mixing container.
 - to bend over the mixing container.
 - to enter the mixing container from above.
-
1. Daily check the cutting knives from the service platform or the ladder for visible defects.
 2. Have damaged or worn cutting knives replaced in good time.
 3. Remove broken-off cutting knife particles from the mixing container to avoid consequential damage.

10.13.2 Replace cutting knives

Operative staff:

- Authorised workshop
-

Observe the safety instructions when entering the mixing container, ► see section 10.6, page 177.

CAUTION

Sharp-edged cutting knives

Risk of cuts.

- Wear cut-resistant protective gloves.
 - Cover the cutting knives by means of an edge protector.
-

CAUTION

Risk of crushing due to magnetic pull

Risk of injury to fingers and hands if tools are pulled by the magnet. Risk of cuts, crushing and even fractures.

- Wear cut-resistant protective gloves.
 - Do not put your free hand onto the magnet.
 - Do not use any magnetic tools if possible.
-

Positionen der Schneidmesser

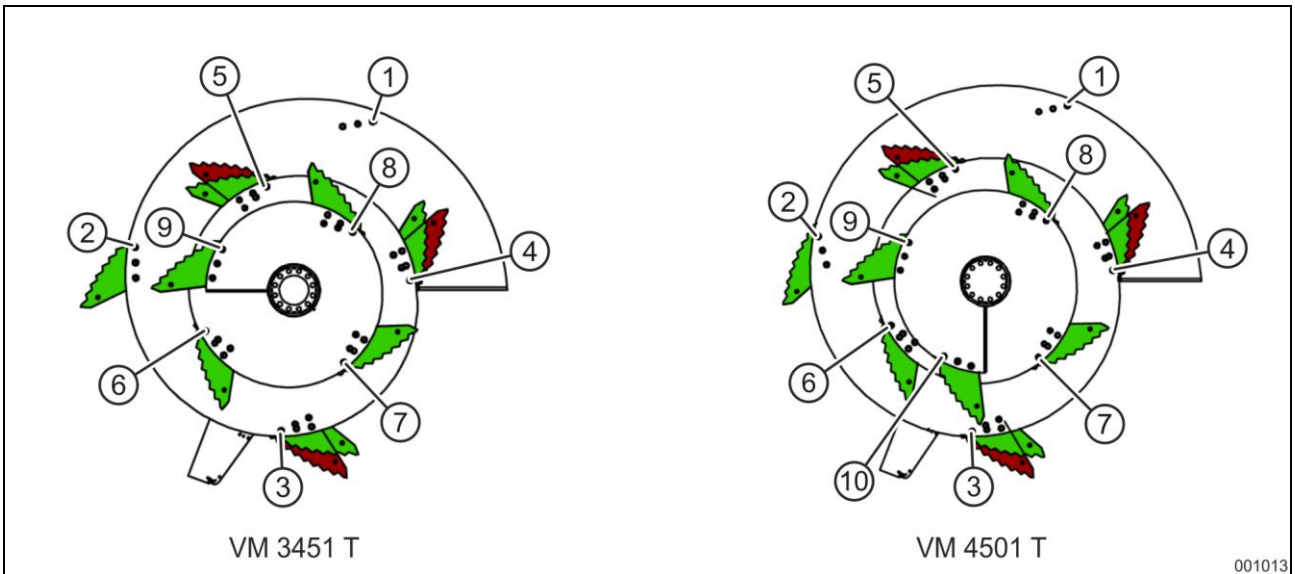

Fig. 122

| Set of knives | Position | | | | | | | | | |
|---------------|----------|---|----|----|----|---|---|---|---|----|
| | 1 | 2 | 3* | 4* | 5* | 6 | 7 | 8 | 9 | 10 |
| Standard | | | | | | | | | | |
| Straw | | | | | | | | | | |
| Bales | | | | | | | | | | |

Tab. 24: Positions – Set of knives

- short knife
- long knife

* The extended cutting knives are most effective in these positions.

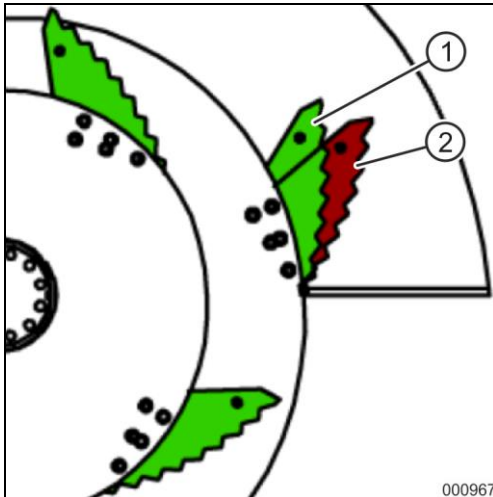

Fig. 123

Some cutting knives can be mounted in two positions:

- Position (1) | retracted (factory setting):
 - Less driving power required
 - Better loosening of bales
- Position (2) | extended:
 - More driving power required
 - Supports the discharge of highly-structured mixtures at the discharge opening
 - Better picking-up of bale components and their re-inclusion in the intensive mixing process.

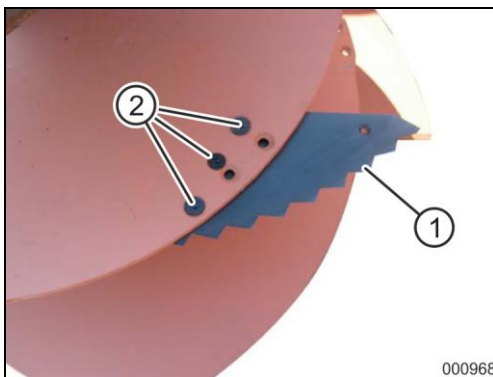

Fig. 124

1. Loosen the screws (2).
2. Change the position of the cutting knife (1) or replace cutting knife.
 - Positioning of individual cutting knives, ► see page 195.



Fig. 125

3. Mount a knife supporting plate beneath the top cutting knife of the mixing auger:
 - Straight knife supporting plate (1) with the "Standard" and "Straw" set of knives.

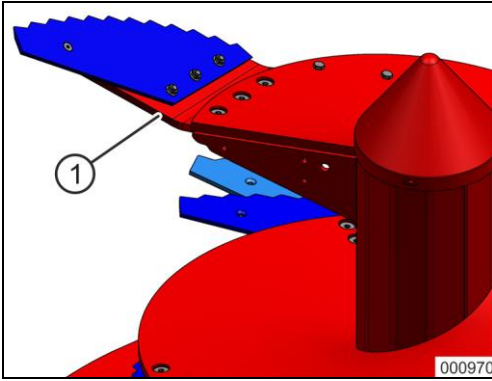

Fig. 126

- Angled bale knife supporting plate (1) with the "Bale" set of knives.

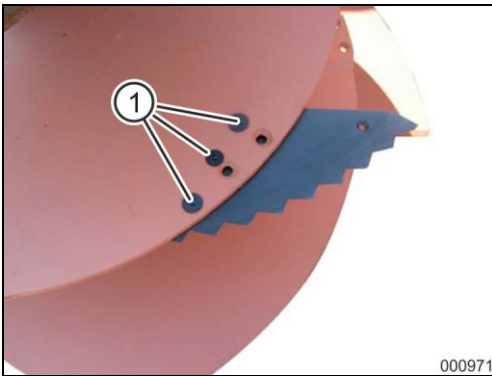

Fig. 127

4. Screw in again and tighten the screws (1).

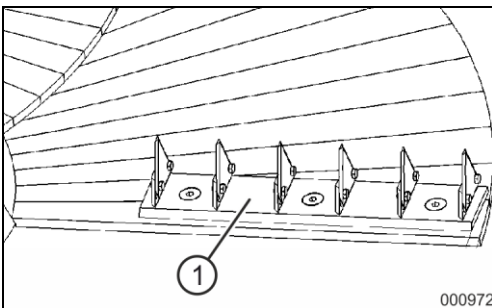

Fig. 128

5. Mount a root crop knife (4) in addition to the cutting knives onto the bottom end of the mixing auger if necessary.
6. Remove any foreign objects (tools etc.) from the mixing container.
7. Thoroughly clean the mixing container.

10.13.2.1 Grind cutting knives

Operative staff:

- Authorised workshop

Observe the safety instructions when entering the mixing container, ► see section 10.6, page 177.

⚠ CAUTION

Sharp-edged cutting knives

Risk of cuts.

- Wear cut-resistant protective gloves.
- Cover the cutting knives by means of an edge protector.

⚠ CAUTION

Eye injuries due to abrasive particles

Flung-away abrasive particles and foreign objects may penetrate the eyes.

- Wear protective goggles.

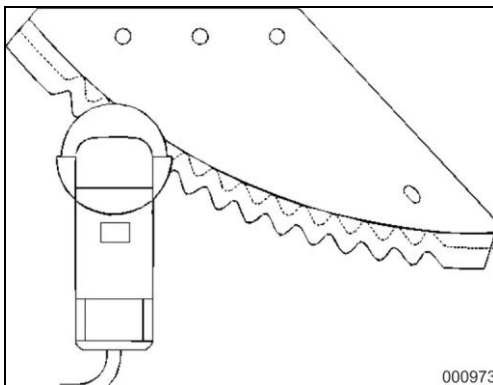

Fig. 129

1. Insert a flap grinding wheel into a right-angle grinder.
2. Carefully grind the cutting knives on their smooth side.
 - Never regrind the cutting knives on their corrugated side.

NOTE

Avoid overheating (discolouration) of the cutting knives during regrinding work. Overheating will reduce the service life of the cutting knives.

3. Remove any foreign objects (tools etc.) from the mixing container.
4. Thoroughly clean the mixing container.

10.14 Mixing auger – Magnetic system

Operative staff:

- Operator

Observe the safety instructions when entering the mixing container, ► see section 10.6, page 177.

⚠ CAUTION

Sharp-edged cutting knives

Risk of cuts.

- Wear cut-resistant protective gloves.
- Cover the cutting knives by means of an edge protector.

⚠ CAUTION

Risk of crushing due to magnetic pull

Risk of injury to fingers and hands if tools are pulled by the magnet. Risk of cuts, crushing and even fractures.

- Wear cut-resistant protective gloves.
- Do not put your free hand onto the magnet.
- Do not use any magnetic tools if possible.

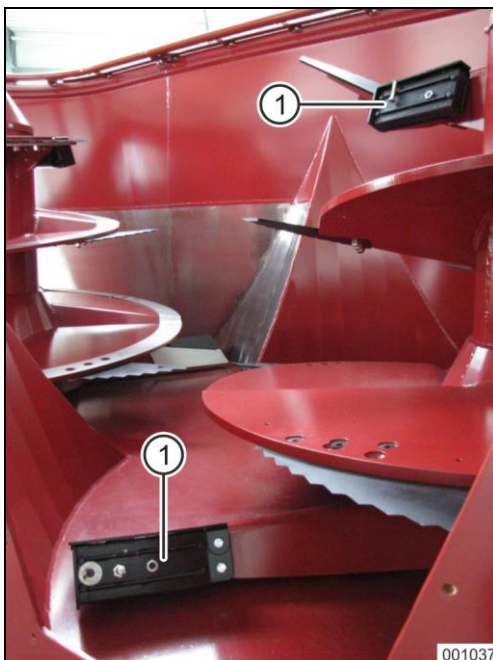

Fig. 130

⚠ WARNING

Implants being affected by electromagnetic fields

Risk of harm to health or even death to persons with electronic implants such as pacemakers due to magnetic fields.

- Keep an adequate safety distance from magnets if you wear an electronic implant.

1. Eliminate all foreign objects from the magnets (1).
2. Remove all foreign objects, tools and other auxiliary materials from the mixing container after cleaning the magnets.

10.15 Crossover conveyor, discharge conveyor, conveyor extension

Incorrect tension of the conveyor belt may cause damage and downtimes of the machine. Therefore, check the tension of the respective conveyor belt every day.

Clean the driving and carrying rollers and pulleys if fodder residues have piled up on the rollers.

The conveyor belt must run straight or must not rub along the frame; straighten it if necessary.

10.15.1 Check and visually check tension of conveyor belt

Operative staff:

- Operator

1. Secure tractor and machine against accidental starting and rolling
2. Check the tension of the conveyor belt.
 - A properly tightened conveyor belt sags by approx. 10 to 15 mm in its centre.
 - The ambient temperature influences the tension. Low temperatures shorten the conveyor, high temperatures lengthen it.
3. Lubricate the flanged bearings of the conveyor belt at least every 50 service hours.
4. Check the conveyor belt (1) and the belt fastener (2) of the conveyor belt for visible defects.
5. Have the conveyor belt replaced by an authorised workshop in case of damage (fissures, raised corners).

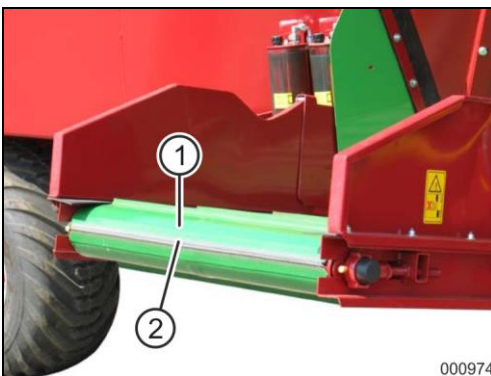

Fig. 131

10.15.2 Tighten and adjust conveyor belt

Operative staff:

- Qualified staff

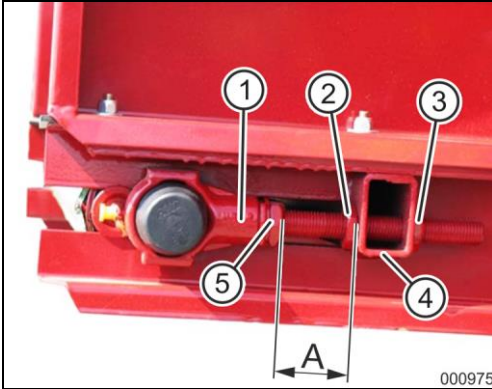

Fig. 132

1. Secure tractor and machine against accidental starting and rolling
2. Unscrew the counter nut (1) at the right-hand and left-hand radial insert ball bearing (2).
3. Equally turn the two clamping nuts (3),
 - The conveyor belt must sag by approx. 10 to 15 mm in its centre.
 - The distance A between the square profiles (4) and the clamping housing (5) must be equal on both sides of the conveyor belt.
4. Carry out a test run.
 - Check whether the conveyor belt has an equal distance to the frame at the return rollers on both sides.
 - Readjust the distance by turning the clamping nuts (3) if necessary.
5. Tighten counter nut (1) at the right-hand and left-hand radial insert ball bearing (2).

10.15.3 Clean driving rollers, carrying rollers and pulleys

Operative staff:

- Qualified staff

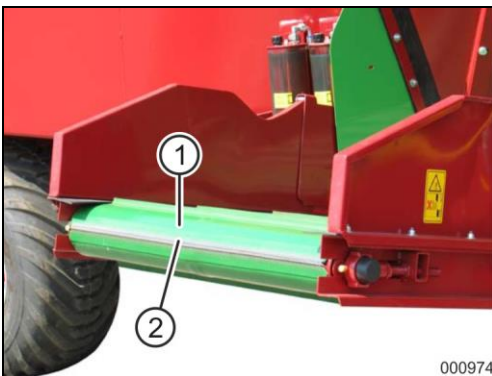

Fig. 133

1. Secure tractor and machine against accidental starting and rolling
2. Relieve the conveyor belt (1).
3. Rotate the relieved conveyor until the side of the belt fastener (2) is positioned on the pulley.
4. Pull the connecting wire out of the belt fastener.
5. Remove the conveyor belt.
6. Clean driving rollers, carrying rollers and pulleys, frame and rubber seal strips.
7. Reinstall the conveyor belt.
 - Ensure that the rubber seal strips rest on top of the conveyor.
8. Mount the connecting wire.
9. Tighten the conveyor belt.

10.16 Mechanical Bowden cable operation

10.16.1 Replace Bowden cable

Operative staff:

- Qualified staff

1. Secure tractor and machine against accidental starting and rolling

Disassembly

Connection to control valve of control block

2. Unscrew the counter nut (9).
3. Loosen both screws (3) at the adapter (10).
4. Remove the pin (2).
5. Strip the connecting sleeve (11) off the sliding pin (12).

Connection to operating element

6. Loosen the locking screw (6).
7. Actuate the operating element (4) until the connecting pin (5) is jutting out.
8. Unscrew the threaded sleeve (7) from the connecting pin (5) with the operating element (4) actuated.
9. Release the operating element (4).
10. Pull the sleeve (8) completely out of the casing.

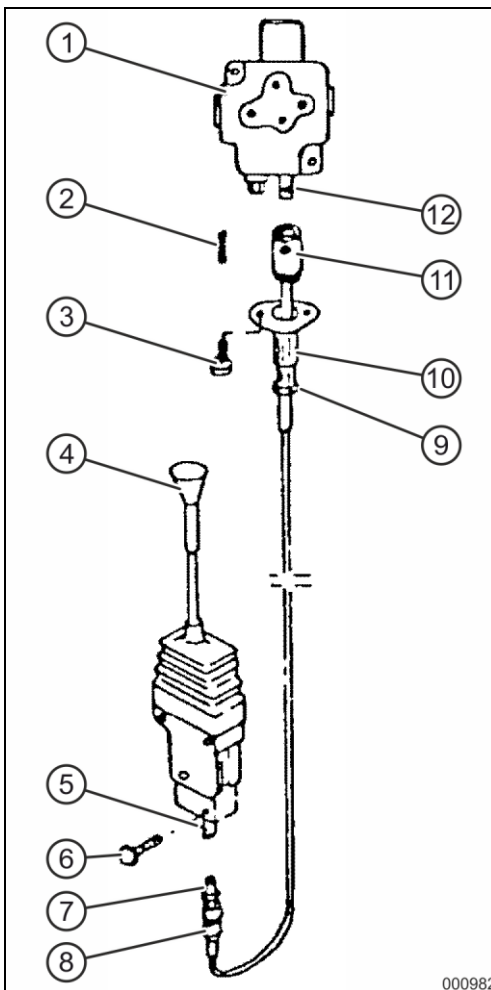

Fig. 134

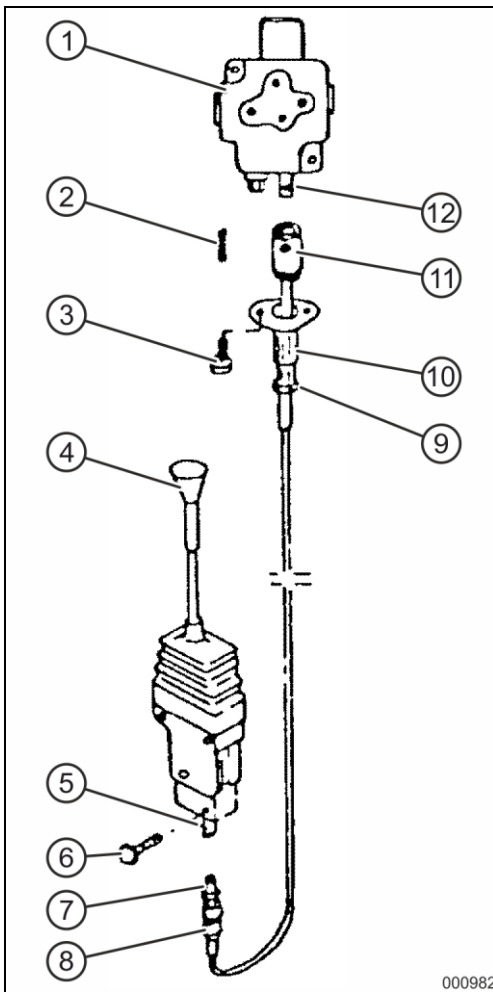

Fig. 135

Assembly

Connection to operating element

1. Actuate the operating element (4) until the connecting pin (5) is jutting out.
2. Screw the threaded sleeve (7) into the connecting pin (5) with the operating element (4) actuated.
3. Release the operating element (4).
4. Insert the sleeve (8) completely into the casing.
5. Screw the locking screw (6) in.

Connection to control valve of control block

6. Actuate the operating element (4) until the connecting sleeve (11) is jutting out of the adapter (10).
 - Possibly loosen the counter nut (9) and turn back the adapter (10).
7. Slip the connecting sleeve (11) onto the sliding pin (12).
8. Connect the connecting sleeve (11) and the sliding pin (12) by means of the pin (2).
9. Turn the adapter (10) until it fits closely to the valve box (1).
10. Use the two screws (3) to screw the adapter (10) to the valve box (1).
11. Tighten the counter nut (9).

10.16.2 Remote control cable – Replace adapter

Operative staff:

- Qualified staff

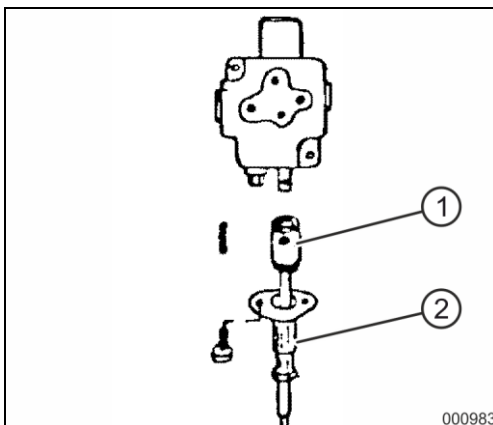

Fig. 136

1. Secure tractor and machine against accidental starting and rolling
2. Remove the connector at the control valve of the control block.
3. Unscrew the counter nut from the connecting sleeve (1).
4. Unscrew the connecting sleeve (1).
5. Replace the adapter (2).
6. Screw the connecting sleeve (1) on.
7. Tighten the counter nut of the connecting sleeve.
8. Mount the connector at the control valve of the control block.

10.17 Hydraulic system

10.17.1 Safety

Hydraulic components under pressure may perform uncontrolled movements in case of improper handling. Furthermore, medium may squirt out under high pressure from pressurised components in case of a malfunction. Risk of serious injuries or even death.

- Only an authorised workshop is allowed to carry out work on hydraulic components.
- Before carrying out any work,
 - depressurise; discharge residual energies.
 - make sure to prevent accidental outflow of the medium.
 - secure lifted movable machine parts against accidental lowering.
 - safely park the machine and secure it against accidental rolling and starting.
- Have all hose pipes checked for their operational safety by an expert at least once a year.
- Regularly check all pipes, hoses and screwed connections for leakage and visible damage. Eliminate damage immediately.
- Never try to plug hose pipe leaks with your hands or fingers. Media squirting out under high pressure may penetrate the skin and enter the body, potentially causing serious injuries.
- Never detect leakages with your bare hands. Immediately contact an authorised workshop if a leak is suspected.
- Immediately contact the medical services if injuries caused by hydraulic oil occur. Risk of serious infection.
- Risk of explosion due to improper work on hydraulic accumulators.
 - Welding, soldering, drilling or other work which might affect the mechanical properties is not allowed.

⚠ CAUTION**Risk of slipping due to leaking oil**

Risk of slipping and falling to people due to leaking oil during topping-up of oil or oil change.

- Immediately remove oil spills by means of binding agents.



- Dispose of used oil properly.
- Ensure that no hydraulic oil penetrates the soil or water.
- Observe the environmental protection rules.

10.17.2 Maintenance intervals**After the first 10 service hours and then every 50 service hours**

Operative staff:

- Qualified staff

1. Check all components of the hydraulic system for tightness.
2. Retighten all screwed connections if necessary.

Before each start-up

Operative staff:

- Operator

1. Check hydraulic hose pipes for visible defects.
2. Remedy or have remedied defects immediately.
 - Eliminate chafing points at hydraulic hose pipes and tubes.
 - Have worn, damaged or aged hydraulic hose pipes immediately replaced (authorised workshop).

10.17.3 Depressurise hydraulic system

⚠ WARNING**Risk of infection due to hydraulic oil squirting out**

Hydraulic oil squirting out under high pressure may penetrate the skin and enter the body, potentially causing serious injuries. Risk of serious infection. This applies in particular to hydraulic systems with a membrane pressure accumulator.

- Never carry out work on the hydraulic system with the system under operating pressure.
 - Depressurise the hydraulic system before carrying out work on the system.
-
- Relieve the respective hydraulic cylinder via the corresponding operating element with the hydraulic pump switched off.

10.17.4 Hydraulic hose pipes

Replace hydraulic hose pipes in case of damage and ageing.

Have hydraulic hose pipes immediately replaced by an authorised workshop if one of the following defects is detected:

- Damaged outer layer down to the liner (e.g. due to chafing points, cuts, cracks)
- Embrittled outer layer (visible by cracking of hose material)
- Unnatural deformations of the hydraulic hose pipe in depressurised as well as in pressurised state or when bent (e.g. separation of layers, blistering, pinches, kinks)
- Leaks
- Damaged, deformed or leaking fitting
- Hose slipping out of the fitting
- Corroded fitting which may affect the function and strength
- Improperly laid hydraulic hose pipes, e.g. ignored bending radii, laying over sharp edges
- Hydraulic hose pipe is older than 6 years

The period of use of the hydraulic hose pipes must not exceed six years, including a maximum possible shelf life of two years.

Even when properly stored and exposed to admissible stress, hoses and hose connections are subject to natural ageing, which involves a limited shelf life and period of use.

Notwithstanding these facts, the period of use may be specified according to experience, in particular taking into account the risk potential.

For thermoplastic hoses and hose pipes, other reference values may be relevant.

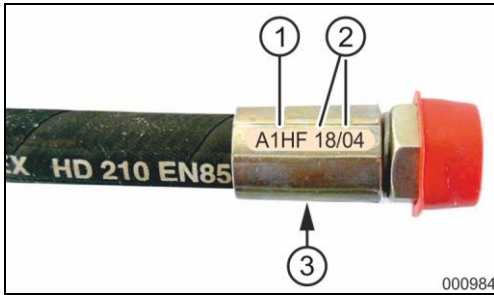

Fig. 137

Markings:

- 1 Manufacturer (A1HF)
- 2 Date of manufacture (18/04 = year/month = April 2018)
- 3 Maximum admissible operating pressure (210 bar)

NOTE

After expiration of the period of use, the hydraulic hose pipe must no longer be used.

Install and remove hydraulic hose pipes**Operative staff:**

- Authorised workshop
-
- Only use original hydraulic hose pipes of the manufacturer.
 - Ensure cleanliness.
 - Install hydraulic hose pipes such that in any operating state
 - there is no tensile stress, except for that due to the dead weight.
 - there is no upsetting stress in case of short lengths.
 - the bending radii do not fall below the admissible limits.
 - external mechanical influences on the hydraulic hose pipes are avoided.
 - Make sure to avoid chafing of hydraulic hose pipes against components or against each other by suitable arrangement and fixing.
 - Protect hydraulic hose pipes by means of protective coatings if necessary.
 - Cover sharp-edged components.
 - When connecting a hydraulic hose pipe to moving parts, the hose length must be such that
 - in the complete range of motion the bending radius does not fall below the minimum admissible limit.
 - the hydraulic hose pipe is not subject to tensile stress.
 - Fix the hydraulic hose pipes to the specified fixing points. Avoid additional hose supports which affect the natural motion and length variation of the hydraulic hose pipes.
 - Overcoating of hydraulic hose pipes is not allowed.

10.17.5 Set hydraulic oil pressure of forced steering axle system

Operative staff:

- Operator

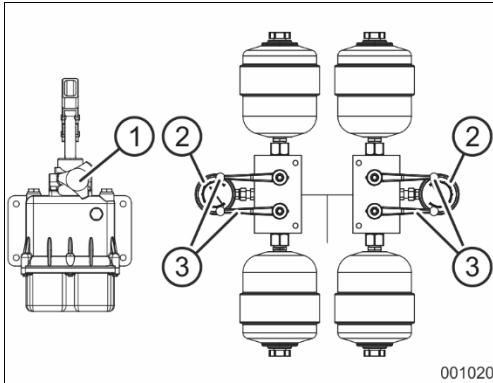

Fig. 138

The machine is properly hitched to the tractor.

1. The pressure gauges (2) indicate the pressure.
 - The pressure must be 70 - 80 bar.
2. Adjust pressure if necessary.
 - Open all stop-cocks (3) of the pump.
 - Open the rotary wheel (1).
 - Make sure that tractor and machine are in a straight line.
 - Close the rotary wheel (1).
 - Preload the hydraulic system evenly to 70 – 80 bar, see pressure gauge (2). Preload each axle separately if necessary, close or open the respective stop-cocks (3) for this purpose.
 - Close all stop-cocks (3).

10.18 Tyres

Assembly and repair work on tyres and wheels requires expert knowledge and appropriate tools.

Operative staff:

- Authorised workshop
-

10.18.1 Safety

As a basic principle, the following is applicable:

- Park the machine on firm, even ground.
- Safely park the machine and secure it against accidental rolling.
- Use lifting equipment with sufficient lifting power to lift the machine.
- Lift the machine only at the marked fixing points.
- Secure the lifted machine/machine parts against accidental lowering.
- Deflate the tyre before removing it.
- Relieve the tyres if the vehicle is not intended to be used for a longer period, thus avoiding deformation of the tyres.
- Store removed tyres in a dark place, free of oil and other chemicals.
- Do not place tyres near electric motors. The ozone produced by the electric motors slowly desiccates the rubber.
- Never overload the tyres.

10.18.2 Check tyres

Check the condition of the tyres and the tyre pressure every day.

Tyre pressure, ► see chapter "Technical data".

Operative staff:

- Operator
-

1. Visually check tyres for damage.
 - Remove foreign objects stuck in the tyre.
 - Have damage such as deeper cuts repaired as soon as possible.
2. Check tyre pressure and refill if necessary.
 - Keep to the side of the wheel when refilling. A compressed-air hose with an approximate length of 1.5 m makes work easier.
3. **⚠ WARNING** – Burst of tyres. Do not exceed the maximum admissible tyre pressure.
4. Check whether the caps are firmly seated on the valves.

10.18.3 Change tyres

Tighten all wheel nuts according to instructions.

Operative staff:

- Qualified staff



Fig. 139



Fig. 140

1. Place the lifting device at the marked fixing points.
2. **▲ WARNING** – Risk of crushing to limbs due to unintentional lowering. Do not stand beneath the lifted machine. Lift machine.
3. Unscrew the wheel nuts.
 - Keep to the order, see numbering.
4. Change the tyres.
5. Tighten the wheel nuts.
 - Screw the wheel nuts crosswise, see numbering.
 - Observe the tightening torque, ► see section 10.4.2, page 166.
 - Threads must be clean and free of grease.
 - Check the wheel nuts 10 hours after completion of assembly and retighten them if necessary. Then check them every 50 service hours for firm seating.

NOTE

Check the distance between underride guard and road after each tyre change. The distance must not exceed 550 mm. Change the position of the underride guard if the distance is more than 550 mm.

10.19 Compressed-air brake system

10.19.1 Drain compressed-air reservoir

Drain the compressed-air reservoir every day before the first journey.

Operative staff:

- Operator



Fig. 141

1. Take the ring (2) and pull the drain valve of the compressed-air reservoir (1) down.
2. Pull until water is no longer pouring out of the compressed-air reservoir.

10.19.2 Check and clean in-line filters

The in-line filters incorporated in the hose couplings of the brake and feed line protect the compressed-air brake system from being soiled by solid particles.

The air supply to the brake system should have priority over the protection of the brake system against soiling and must be ensured in all conditions. In case of the filter element being clogged due to soiling, an internal bridging-over element opens and unfiltered air passes through the hose coupling.

- Regularly check the degree of soiling of the filter elements in the hose couplings.
- Clean heavily soiled filter elements approx. every 3-4 months, depending on the operating conditions.
- Replace damaged filter elements.

Operative staff:

- Qualified staff

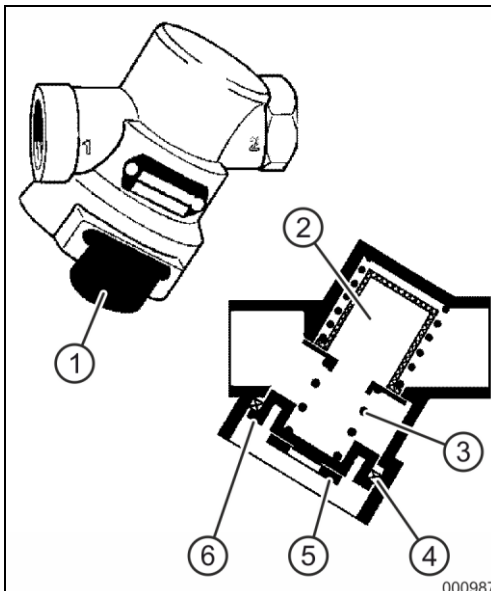

Fig. 142

1. Disconnect feed and brake line from the tractor.
2. Push in the base plate (6).
3. Release the slide valve (5).
4. Remove the base plate with O-Ring (4), the pressure spring (3) and the filter element (2) from the casing.
5. Check degree of soiling.
6. Rinse the filter element with benzine or thinner.
7. Use compressed air to blow the filter element dry.
8. Reinsert the filter element, the pressure spring and the base plate with O-ring into the casing.
 - Ensure that the O-ring will not get jammed in the guiding slot during insertion.
9. Close the slide valve.
10. Connect the feed and brake line to the tractor.
11. Check the in-line filters for tightness.

10.19.3 Check brake system for proper functioning.

As a basic principle, the operator has to check the brake system for proper functioning before each start-up of the machine.

Immediately contact an authorised workshop in case of irregularities or malfunctions of the brake system.

- Have the brake system checked by an authorised workshop for proper functioning every 200 service hours.
- Have the brake readjusted in case of a use of approx. 2/3 of the maximum cylinder stroke in case of full brake application.

Operative staff:

- Operator (before each journey)
 - Authorised workshop (every 200 service hours)
-

10.19.4 Set compressed-air brake system

Readjust the brake system if the free travel X is ≥ 30 mm.

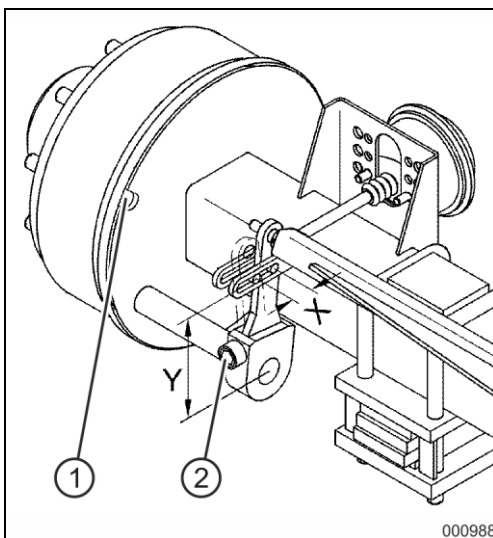

Fig. 143

1. Secure tractor and machine against accidental starting and rolling
2. Disconnect the brake and feed line of the brake system.
3. Manually actuate the brake lever in pressing direction.
4. Press the circlip at the adjusting screw (2) down and set the free travel X by means of the adjusting screw:
 $X = 0.1 \times \text{length of brake lever } Y$
5. Check the brake linings (1).
 Replace the brake linings in case of a remaining lining thickness of:
 - 5 mm in case of riveted linings
 - 2 mm in case of glued linings
6. Replace the brake linings as required.

10.19.5 Set hydraulic brake system

Readjust the brake system if the free travel X is ≥ 40 mm.

Operative staff:

- Authorised workshop

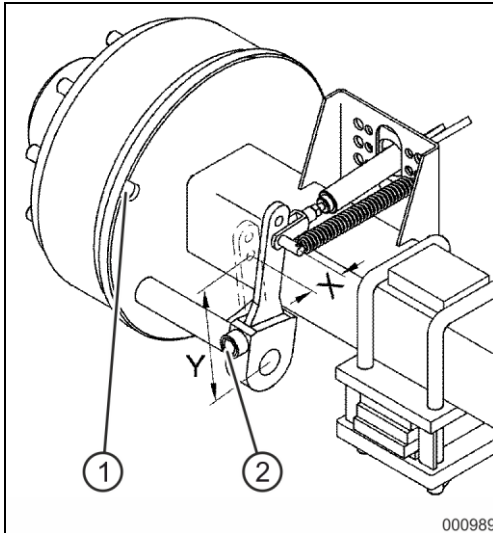

Fig. 144

1. Secure tractor and machine against accidental starting and rolling
2. Disconnect the hydraulic hose pipe from the brake system.
3. Manually actuate the brake lever in pressing direction.
4. Press the circlip at the adjusting screw (2) down and set the free travel X by means of the adjusting screw:
 $X = 0.1 \times \text{length of brake lever } Y$
5. Check the brake linings (1).
 Replace the brake linings in case of a remaining lining thickness of:
 - 5 mm in case of riveted linings
 - 2 mm in case of glued linings
6. Replace the brake linings as required.

10.20 Check brake linings

Operative staff:

- Operator

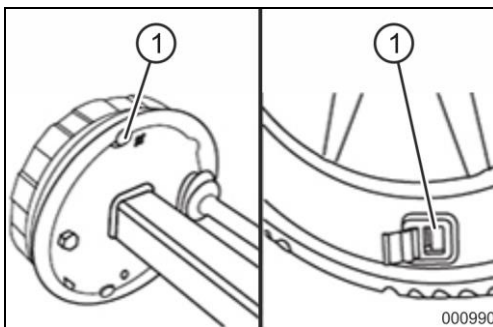

Fig. 145

1. Secure tractor and machine against accidental starting and rolling
2. Open the inspection hole (1).
 - Pull the rubber plug out (if available).
3. Check the brake linings.
 Replace the brake linings in case of a remaining lining thickness of:
 - 5 mm in case of riveted linings
 - 3 mm in case of N 2504 linings
 - 2 mm in case of glued linings
4. Have the brake linings replaced by an authorised workshop if necessary.
5. Reinsert the rubber plug after the check.

10.21 Lubricate brake shaft bearing

Operative staff:

- Operator

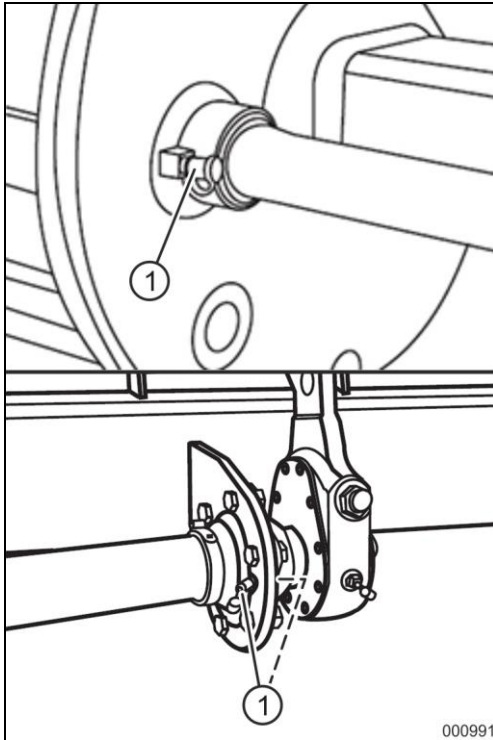

Fig. 146

1. Secure tractor and machine against accidental starting and rolling
2. Lubricate the outer and inner lubrication points (1) with long-life grease until fresh grease comes out of the bearings.
 - Only use lithium-saponified grease with a drop point above 190°C.

NOTE

Depending on the series, the cam bearing may not be sealed on the brake side.

Make sure that no grease or oil enters the brake system.

10.22 Lubricate manual slack adjuster

Operative staff:

- Operator

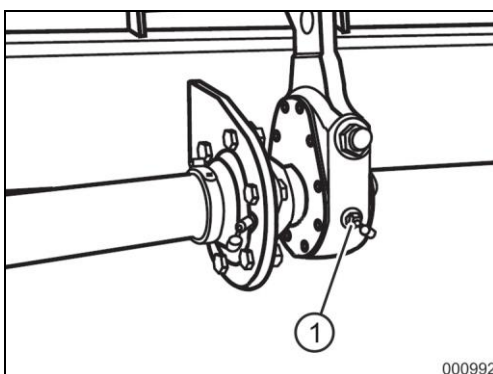

Fig. 147

1. Secure tractor and machine against accidental starting and rolling
2. Lubricate the outer and inner lubrication points (1) with long-life grease until fresh grease comes out of the bearings.
 - Only use lithium-saponified grease with a drop point above 190°C.

10.23 Lubricate knuckle arm bearing

Operative staff:

- Operator

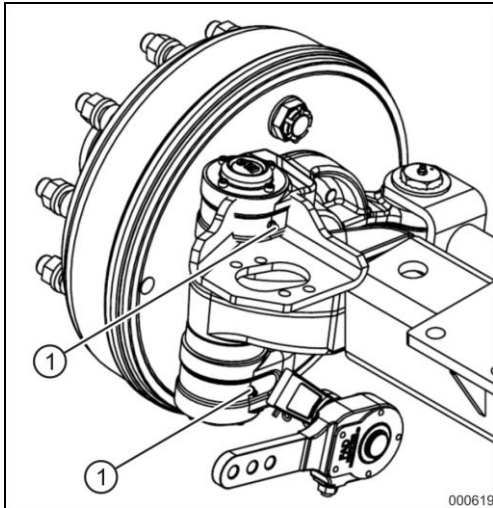

Fig. 148

1. Secure tractor and machine against accidental starting and rolling
2. Lubricate the lubrication points (1) at the top and bottom of the knuckle arm bearing with long-life grease until fresh grease comes out of the bearings.
 - Only use lithium-saponified grease with a drop point above 190°C.

10.24 Check play of wheel hub bearing

Operative staff:

- Qualified staff

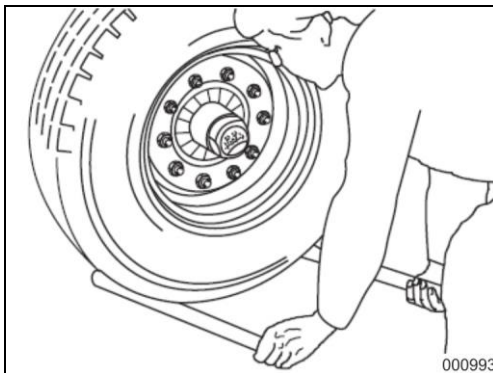

Fig. 149

1. Secure tractor and machine against accidental starting and rolling
2. Place the lifting device (jack) at the marked fixing points.
3. Lift the axle only until the tyres clear the ground.
4. Release the brake.
5. Place two levers between tyres and ground and check the bearing play.
 - Have the bearing readjusted by an authorised workshop if there is a noticeable bearing play.

11 Spare parts

NOTE

Immediately replace machine parts which are not in sound condition.

The manufacturer does not assume any liability for damage resulting from the use of non-approved parts or auxiliary materials and consumables.

In case of replacement, only use original parts or parts approved by the manufacturer. Use of other parts not meeting the technical specifications of the manufacturer may cause damage.

- Please contact the service for spare parts orders. Order information can be transmitted via e-mail, fax or phone.
- It is imperative to indicate the data of the front page or of the spare parts list when ordering spare parts:
 - Machine ID number
 - Spare parts list number (if available)
 - Article number (if available)
 - Article designation
 - Quantity
- The manufacturer recommends to stock spare and wearing parts according to the spare parts list, in order to reduce or avoid standby and downtimes in case of a malfunction.

13 Index

A

| | |
|-----------------------------|----|
| Abbreviations | 16 |
| Adapt mounting height | 83 |
| Anchorage points | 66 |
| Applied terms | 16 |
| Axles | 30 |

B

| | |
|------------------------------------|-------------|
| Ball-type coupling | 87, 89 |
| Battery for weighing device | 115 |
| Bolt-type coupling | 85, 88 |
| Bowden cable control set | 119 |
| Mount | 114 |
| Bowden cable operation | 202 |
| Brake system | 29, 55, 102 |
| Check for proper functioning | 215 |
| Compressed-air | 57 |

C

| | |
|--|---------|
| Change gear level | |
| Power shift gearbox | 147 |
| Switchgear | 145 |
| Chassis | 51 |
| Check brake linings | 216 |
| Check machine for proper functioning | 99 |
| Chemical substances | 28 |
| Clean machine | 179 |
| Clean oil cooler | 180 |
| Commissioning | 67 |
| Compressed-air brake system | 57, 213 |
| Set braking force | 104 |
| Connections | 53 |
| Container extension | 110 |
| Control set | |
| Symbols | 124 |
| Conveyor belt | |
| Check tension | 200 |
| Clean rollers | 201 |
| Tighten and adjust | 201 |
| Conveyor extension | 200 |
| Correct use | 17 |
| Couple | |
| Drawbar | 85 |
| Forced steering axle | 79 |
| Coupling devices | 71 |
| Crossover conveyor | 200 |
| Cutting knives | |
| Check | 193 |
| Grind | 198 |

| | |
|-----------------|-----|
| Positions | 195 |
| Replace | 194 |

D

| | |
|--------------------------------------|------------|
| Dc value | 72 |
| Description of machine | 48 |
| Dimensions of wagon | 46 |
| Discharge conveyor | 200 |
| Discharge fodder | 140 |
| Discharge options | 61 |
| Dosage gate | 192 |
| Drain compressed-air reservoir | 213 |
| Draw pin | 86, 89 |
| Drawbar | 54, 83 |
| Drawbar lug | 86, 88, 89 |
| Drawgears | 71 |

E

| | |
|----------------------------------|----------|
| E-control set | 112, 123 |
| Mount | 114 |
| Electrical energy | 27 |
| Emergency draining | 149 |
| Emergency manual operation | 159 |
| Environmental protection | 13, 30 |

F

| | |
|------------------------------------|--------|
| Fast bedding roller | 143 |
| Feed funnel for mineral feed | 59 |
| Fill machine | 134 |
| Fixed supporting leg | 98 |
| Forced steering axle system | 52, 78 |
| Hydraulic oil pressure | 209 |
| Foreseeable misuse | 18 |

G

| | |
|--------------------------|-----|
| Gear lubricant oil | 181 |
| General data | 45 |
| General overview | 49 |

H

| | |
|-------------------------------|------------|
| Hitch | |
| Machine | 75 |
| Hitch hook | 86, 88 |
| Hitch ring | 86, 88, 89 |
| Hot spots | 28 |
| Hydraulic energy | 26 |
| Hydraulic hose pipes | 100, 207 |
| Connect | 101 |
| Disconnect | 101 |
| Hydraulic system | 53, 204 |
| Depressurise | 206 |
| Hydraulic working brake | 55, 102 |

| | |
|---------------------------------------|---------------------------|
| I | |
| In-line filter | 214 |
| Instruction signs | 41 |
| Instructions | 12 |
| L | |
| Lashing points | 66 |
| Liability | 31 |
| List of malfunctions | |
| Electrical system | 157 |
| Machine | 156 |
| Weighing device | 158 |
| Lists | 12 |
| Location details | 13 |
| Lubricants | 163 |
| Lubricate brake shaft bearing | 217 |
| Lubricate knuckle arm bearing | 218 |
| Lubricate machine | 180 |
| Lubricate slack adjuster | 217 |
| Lubrication plan | |
| Chassis | 175 |
| Machine | 174 |
| M | |
| Magnetic system | 60, 199 |
| Maintenance | 161 |
| Maintenance plan | |
| Chassis | 171 |
| Machine | 168 |
| Malfunctions | 155 |
| Misuse | 18 |
| Mix fodder components | 138 |
| Mixer gearbox | 182 |
| Mixing auger | 59 |
| Mixing container | 59, 177 |
| Mount control set | 114 |
| Mount counter-cutters | 139 |
| Mounting of assemblies | 93, 94 |
| Moving parts | 25 |
| N | |
| Navigation layout | 130 |
| O | |
| Operating media | 163 |
| Operation | 118, 132 |
| Operator's obligation | 20 |
| Other relevant documents | 11 |
| P | |
| Parking brake | 58, 108 |
| Passive steering axle | 51 |
| Personal protective equipment | 23 |
| Piton-Fix | 86, 89 |
| Pneumatic energy | 26 |
| Power shift gearbox | 147, 149 |
| Information display | 129 |
| Power shift gearbox (2-gear) | 185 |
| Power shift gearbox (3-gear) | 188 |
| Propeller shaft | 90 |
| Adapt length | 91 |
| Couple to tractor | 93 |
| Uncouple from tractor | 94 |
| Protective devices | 33 |
| R | |
| References | 13 |
| Remote control cable | 203 |
| Replace Bowden cable | 202 |
| Representational conventions | 12 |
| Required tractor equipment | 69 |
| Residual risks | 23 |
| Risk levels | 14 |
| Risk potential | 23 |
| S | |
| Safe parking | 154 |
| Safety | 17, 65, 67, 132, 155, 161 |
| Safety and protective devices | 32 |
| Safety devices | 33 |
| Secure conveyor extension | 153 |
| Secure discharge conveyor | 153 |
| Secure protective devices | 152 |
| Service | 161 |
| Service brake | |
| Hydraulic | 56, 108 |
| Set compressed-air brake system | 215 |
| Set conveyor speed | 111 |
| Set deflector plate | 117 |
| Set hydraulic brake system | 216 |
| Shear bolt coupling | 191 |
| Shell | 87, 89 |
| Signage | 35 |
| Signal words | 14 |
| Signs | 35 |
| Spare parts | 219 |
| Staff requirements | 21 |
| Steering axle | 51 |
| Supporting leg | 95 |
| Fixed supporting leg | 98 |
| Hydraulic | 97 |
| Mechanical | 95 |
| Switchgear | 145, 184 |
| T | |
| Target group | 11 |

| | |
|---------------------------------|--------|
| Technical alterations | 19 |
| Technical data | 45 |
| Tightening torques | 164 |
| Metric standard threads | 165 |
| Tow hook | 86, 88 |
| Towing capacity | 72, 74 |
| Tractor direct connection | 118 |
| Tractor's compatibility | 68 |
| Traffic-related equipment | 63 |
| Transport | 65 |
| Transport journeys | 150 |
| Type plate | 64 |
| Tyres | 210 |
| Change | 212 |
| Check | 211 |

U

| | |
|----------------------------|----|
| Uncouple | |
| Drawbar | 88 |
| Forced steering axle | 82 |
| Unhitch | |
| Machine | 75 |
| User's obligation | 20 |

W

| | |
|--------------------------|---------|
| Warning signs | 14, 35 |
| Warranty | 31 |
| Wheel hubs | |
| Check bearing play | 218 |
| Wheel nuts | 166 |
| Working brake | 55, 102 |

| Author | Releasing person | Date of release | Language |
|---------------|-------------------------|------------------------|-----------------|
| KB | LB | 22.01.2019 | englisch |

| Assignment | |
|----------------------|--|
| Product group | Futtermischwagen |
| Goods group | Verti-Mix Triple |
| Model | Verti-Mix 3451 Triple, Verti-Mix 4501 Triple |