



straumann

Translation of the Original Operating Instructions

Self-propelled fodder mixing wagon

Sherpa 1201 / 1401

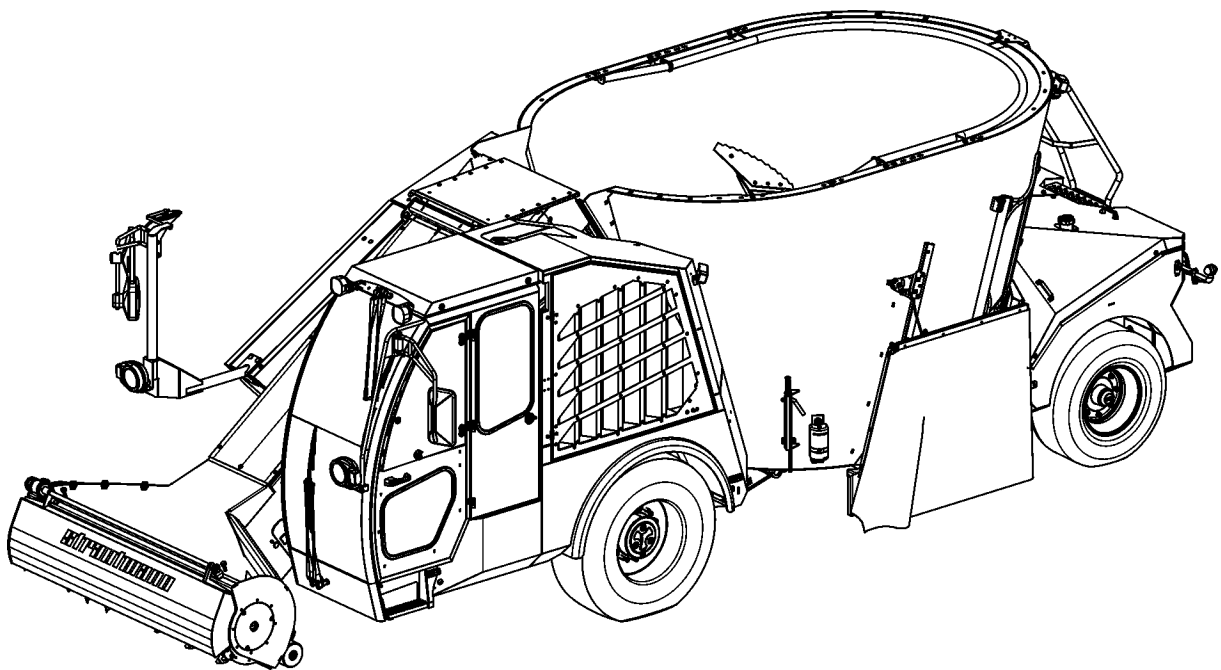

66300931 0.000

08.16





EU Declaration of Conformity

Manufacturer:

B. Strautmann & Söhne GmbH u. Co. KG
Bielefelder Str. 53
D-49196 Bad Laer

Legal person established within the EC and authorized to compile the technical documentation:

B. Strautmann & Söhne GmbH u. Co. KG
Bielefelder Str. 53
D-49196 Bad Laer

Description and identification of machine:

Designation: Self-propelled fodder mixing wagon
Function: Removal, charging, chopping, mixing, transport and discharge of all types of silage and normal fodders used in keeping livestock
Model: Sherpa
Type: 1201, 1401
Serial number: W09663000_0S38001 - W09663000_0S38999
W09665000_0S38001 - W09665000_0S38999
Trade name: Self-propelled fodder mixing wagon Sherpa

We hereby explicitly declare that the machine complies with all relevant provisions of the following directives:

2006/42/EC:2006-05-17 EC machinery directive 2006/42/EC
2014/30/EU:2014-02-26 (Electromagnetic compatibility) Directive 2014/30/EU of the European Parliament and the Council dated 26 February 2014 for harmonisation of laws of the member states on the electromagnetic compatibility (revised version)

Sources of the applied harmonized standards:

EN ISO 12100:2010 Safety of machinery - Basic concepts, general principles of design - Risk assessment and risk reduction
EN ISO 13857:2008 Safety of machinery - Safety distances to prevent hazard areas from being reached by upper and lower limbs
EN ISO 4254-1:2013 Agricultural machinery - Safety - Part 1: General requirements
EN 349:1993+A1:2008 Safety of machinery - Minimum distances to prevent limbs from being crushed
EN ISO 4413:2010 Fluid power - General rules and safety requirements for hydraulic systems and their components
EN 703:2004+A1:2009 Agricultural machinery - Silage loading, mixing and/or chopping and distributing machines - Safety

Bad Laer, 04/01/2016

Dipl.-Kfm. W. Strautmann
Managing Director

Identification data

Please enter the machine's identification data here. They are registered on the type plate.

Manufacturer: B. Strautmann & Söhne GmbH u. Co. KG

Vehicle/Machine ID number: _____

Type:

Year of manufacture:

Manufacturer's address

B. Strautmann & Söhne GmbH u. Co. KG

Bielefelder Straße 53

D-49196 Bad Laer

Phone: + 49 (0) 5424 802-0

Fax: + 49 (0) 5424 802-64

E-mail: info@strautmann.com

Spare parts order service

B. Strautmann & Söhne GmbH u. Co. KG

Bielefelder Straße 53

D-49196 Bad Laer

Phone: + 49 (0) 5424 802-30

Fax: + 49 (0) 5424 802-64

E-mail: parts@strautmann.com

Spare parts catalogue online: www.strautmann-elise.de

Please always refer to the vehicle/machine ID number of your machine when ordering spare parts.

Formal information about the operating instructions

Document number: 66300931 0.000

Date of compilation: 08.16

© Copyright B. Strautmann & Söhne GmbH u. Co. KG, 2016

All rights reserved.

Reproduction, even in excerpts, only allowed with the permission of B. Strautmann & Söhne GmbH u. Co. KG.



Operating instructions, spare parts lists and brochures are also available in the Strautmann information library on the internet:

www.strautmann-infothek.de



The operating instructions for the diesel engine are also available on the Internet at:

www.perkins.com/SEBU8172

Foreword

Dear customer,

You have decided in favour of a quality product from the large B. Strautmann & Söhne GmbH u. Co. KG product range. We thank you for the confidence you have shown in us.

Upon receipt of the machine, please check for transport damage or missing parts! Check the delivered machine for its completeness, including the ordered optional extras, by means of the delivery note. Only immediate complaints will give reason to compensation!

Read and observe these operating instructions and any other included operating instructions for individual machine components before the first start-up; in case of doubt, the details and information contained in such sub-supplier documentation shall prevail! In particular observe the safety instructions, thus being able to fully benefit from the advantages of your recently acquired machine.

Please make sure that all operators of the machine have read these operating instructions before starting the machine.

The machines are available with various optional extras. Due to the individual equipment of your machine, not all descriptions included in these operating instructions apply to your machine. Optional extras are marked in these operating instructions and are available at extra cost.

In case of any inquiries or problems, please refer to these operating instructions or call us.

Regular service and maintenance and timely replacement of worn-out or damaged parts will result in a longer service life of your machine.

Contents

1 User information 8

- 1.1 Purpose of document 8
- 1.2 Keeping of operating instructions 8
- 1.3 Location details in the operating instructions 8
- 1.4 Applied modes of specification 8
- 1.5 Applied terms 9
- 1.6 Activity-related safety instructions and important information 9
 - 1.6.1 Activity-related safety instructions 9
 - 1.6.2 Important information 10

2 Product description 11

- 2.1 General overview of machine 12
- 2.2 Driver's cabin 14
- 2.3 Electrical system 16
 - 2.3.1 Battery main switch 16
 - 2.3.2 Fuses 16
 - 2.3.3 Relays 18
- 2.4 Hydraulic system of machine 19
 - 2.4.1 Stop-cocks 19
- 2.5 Type plate 20
- 2.6 Technical data 20

3 Safety instructions 22

- 3.1 Correct use 22
- 3.2 Safety-conscious working 22
- 3.3 Organisational measures 23
 - 3.3.1 User's obligation 23
 - 3.3.2 Operator's obligation 23
 - 3.3.3 Qualification of operator 24
- 3.4 Product safety 24
 - 3.4.1 Hazardous areas and dangerous spots 24
 - 3.4.2 Safety and protective devices 25
 - 3.4.3 Structural alterations 25
 - 3.4.4 Spare and wearing parts, auxiliary materials 25
 - 3.4.5 Warranty and liability 25
- 3.5 Basic safety instructions 26
 - 3.5.1 General safety and accident prevention instructions 26
 - 3.5.2 Hydraulic system 29
 - 3.5.3 Electrical system 30
 - 3.5.4 Diesel engine 30
 - 3.5.5 Brake system 31
 - 3.5.6 Axles 31
 - 3.5.7 Tyres 31
 - 3.5.8 Service and maintenance of machine 32
- 3.6 Warning and instruction signs 33
 - 3.6.1 Warning signs 33
 - 3.6.2 Instruction signs 38
 - 3.6.3 Placing of warning and instruction signs 39
- 3.7 Risks in case of non-observance of safety instructions and warning signs 40

4 Commissioning 41

- 4.1 Open cabin door 41
- 4.2 Get in and out 41
- 4.3 Open door window 42

- 4.4 Adjust driver seat 43
- 4.5 Adjust steering wheel position 44
- 4.6 Switch parking or driving light on and off 44
- 4.7 Actuate indicators, full headlights, headlight flasher, horn 45
- 4.8 Switch work lights on / off 45
- 4.9 Switch interior light on/off 46
- 4.10 Unroll/Roll up sun blind 46
- 4.11 Switch windscreen wiper on/off 47
- 4.12 Adjust outside mirror 47
- 4.13 Ventilate / Heat driver's cabin 48
- 4.14 Remove / Fix radio remote control 48
- 4.15 Extend / Retract counter-cutters 49
- 4.16 Set deflector plate 50
- 4.17 Preheating devices 51

5 Operation 53

- 5.1 Switches / Key buttons of control console 53
- 5.2 Joystick 56
- 5.3 Terminal 57
 - 5.3.1 "Parameter / Diagnosis" menu 58
 - 5.3.2 "Diagnosis" menu 59
 - 5.3.3 "Parameter" menu 64
- 5.4 Manual throttle lever 66

6 Travelling mode 67

- 6.1 Road traffic regulations 67
- 6.2 Start diesel engine 67
- 6.3 Winter operation of diesel engine 68
- 6.4 Travelling and braking 68
- 6.5 Turn off diesel engine 69

7 Use of machine 71

- 7.1 Fill fodder mixing wagon 71
 - 7.1.1 Recommended filling order 71
 - 7.1.2 Pick up silage from the bunker silo 71
 - 7.1.3 Pick up bales, bulk materials and other items 74
 - 7.1.4 Fill in fodder additives through hydraulic feed hopper 75
- 7.2 Mix fodder components 76
- 7.3 Fodder discharge 77
 - 7.3.1 Eliminate blockages 78

8 Service and maintenance of machine 79

- 8.1 Secure pick-up arm against accidental lowering 80
- 8.2 Enter the mixing container 82
- 8.3 Operating media 83
- 8.4 Service and maintenance plan - Overview 84
- 8.5 Preservation/Longer downtimes 86
- 8.6 Cleaning of machine 86
- 8.7 Lubrication of machine 87
 - 8.7.1 Lubrication plan 88
- 8.8 Refuelling 88
- 8.9 Diesel engine - Check / Top up oil level 89
- 8.10 Check / Top up coolant level 91
- 8.11 Check / Top up hydraulic oil level 91

- 8.12 Clean ventilation filter 92
 - 8.13 Top up windscreen washing water 93
 - 8.14 Replace wiper blades 94
 - 8.15 Clean / Replace air circulation and fresh air filter 94
 - 8.16 Check/Top up/Change gear lubricant oil 96
 - 8.16.1 Milling drum gearbox 96
 - 8.16.2 Mixer gearbox 97
 - 8.17 Check / Adjust discharge door distance 97
 - 8.18 Swivel / Replace cutting knives 98
 - 8.19 Grind cutting knives 101
 - 8.20 Tighten / Align side discharge conveyor 102
 - 8.21 Adjust supporting rollers 102
 - 8.22 Adjust scraper bar 103
 - 8.23 Check tension of elevator conveyor 104
 - 8.24 Turn over / Replace milling blades of pick-up milling cutter 104
 - 8.25 Cutting unit 105
 - 8.25.1 Check cutting unit 105
 - 8.25.2 Readjust Fast-Cut cutting knives 107
 - 8.25.3 Replace Fast-Cut cutting knives and/or slide plates 108
 - 8.26 Check hydraulic hose pipes 108
 - 8.27 Wheel change 109
 - 8.28 Tightening torques for screwed connections 110
 - 8.29 Adjust travelling height of hydraulic chassis 111
 - 8.30 Check / Top up central lubrication 113
- 9 Remedy of malfunctions 114**
- 9.1 Start diesel engine by means of a jumper battery 114
 - 9.2 Tow machine 115
 - 9.2.1 Open hydraulic oil circulation system of traction drive 116
 - 9.2.2 Manual release of parking brake 117
 - 9.3 Emergency manual operation in case of failure of electrical system 118
 - 9.4 Lift pick-up arm via emergency lifting device 118
 - 9.5 Overview of other malfunctions and remedial actions 120
- 10 Disassembly / Disposal 122**
- 11 Circuit diagrams 123**
- 11.1 Hydraulics 123
 - 11.1.1 Operating hydraulics 123
 - 11.1.2 Pump hydraulics 125
 - 11.1.3 Traction drive hydraulics 127
 - 11.1.4 Mixing unit hydraulics 128
 - 11.1.5 Steering hydraulics 129

1 User information

The chapter "User information" provides information about how to use the operating instructions.

1.1 Purpose of document

These operating instructions:

- describe the operation, service and maintenance of the machine,
- provide important information about safety-conscious and efficient handling of the machine.

Please contact us for further inquiries.

1.2 Keeping of operating instructions

The operating instructions are part of the machine.

Therefore, always keep these operating instructions in the machine.

Hand these operating instructions over to the buyer when the machine is sold.

1.3 Location details in the operating instructions

Any directional data in these operating instructions refer to the direction of motion.

1.4 Applied modes of specification

Instructions and responses

Activities which have to be carried out in a predetermined order are specified as numbered instructions. Always adhere to this order. In some cases, the response of the machine to the respective instruction is marked by an arrow.

Example:

1. Instruction 1
→ Response of machine to instruction 1
2. Instruction 2

Lists

Lists without predetermined order are specified as lists with bullet points.

Example:

- Item 1
- Item 2

Position numbers in figures

Numbers in parentheses refer to position numbers in figures. The first number refers to the figure, the second number to the position number in the figure.

Example: (Fig. 3/6) means figure 3, position 6.

Lines of position in figures

Starting from the position numbers, the lines of position refer to the respective components.

A line without an arrow head means:



the component can be seen in the figure,

A line with an arrow head means:

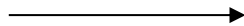

the component cannot be seen in the figure (e.g. hidden by protective device).

References

An arrow head (▶) in front of a sentence indicates a reference to further information elsewhere in the operating instructions.

Example:

▶ Also observe the information in the chapter "Technical data", page 20.

1.5 Applied terms

Term	The term means
third person/party	... all other persons apart from the operator.
risk	... the source of a possible injury or damage to health.
manufacturer	... B. Strautmann & Söhne GmbH u. Co. KG.
machine	... Self-propelled fodder mixing wagon Sherpa 1201 / 1401.
operating element	... the component of an operating element system which is directly actuated by the operator, e. g. by pressing. An operating element may be an adjusting lever, a key button, rotary switch, key etc.

1.6 Activity-related safety instructions and important information

Activity-related safety instructions and important information are included in the operating instructions. Signal words and symbols help to identify activity-related safety instructions and important information at a glance.

1.6.1 Activity-related safety instructions

Activity-related safety instructions:

- warn about risks which may occur in a certain situation or in connection with a certain behaviour,
- are directly mentioned in front of a hazardous activity in the individual chapters,
- are marked by the triangular hazard symbol and a preceding signal word. The signal word refers to the seriousness of the risk.

DANGER



DANGER

marks a direct danger bearing a high risk, which will cause most serious bodily injury (loss of limbs or long-term harm) or even death if it is not prevented.

Non-observance of the safety instructions marked by "DANGER" directly causes most serious bodily injury or even death.

WARNING



WARNING

marks a possible danger bearing a moderate risk, which might cause most serious bodily injury or even death if it is not prevented.

Non-observance of the safety instructions marked by "WARNING" may cause most serious bodily injury or even death.

CAUTION



CAUTION

marks a possible danger bearing a low risk, which might cause light or moderate bodily injury or material damage if it is not prevented.

Non-observance of the safety instructions marked by "CAUTION" may cause light or moderate bodily injury or material damage.

1.6.2 Important information

Important information:

- provides details for proper use of the machine,
- provides user hints for optimum use of the machine,
- is marked by the following symbols.



IMPORTANT

marks an obligation to behave in a particular manner or to act in a certain way, in order to use the machine properly.

Non-observance of these instructions may cause malfunctions of the machine or in its vicinity.



INFORMATION

marks user hints and particularly useful information.

This information will help you to use all functions of your machine in the best possible way.

2 Product description

This chapter includes

- comprehensive information about the machine design,
- the designations of the individual assemblies and operating elements.

Please read this chapter in the immediate vicinity of the machine if possible, thus acquainting yourself with the machine in the best possible way.

The machines are available with various optional extras. Due to the individual equipment of your machine, not all descriptions included in these operating instructions apply to your machine. Optional extras are marked in these operating instructions and are available at extra cost.

2.1 General overview of machine

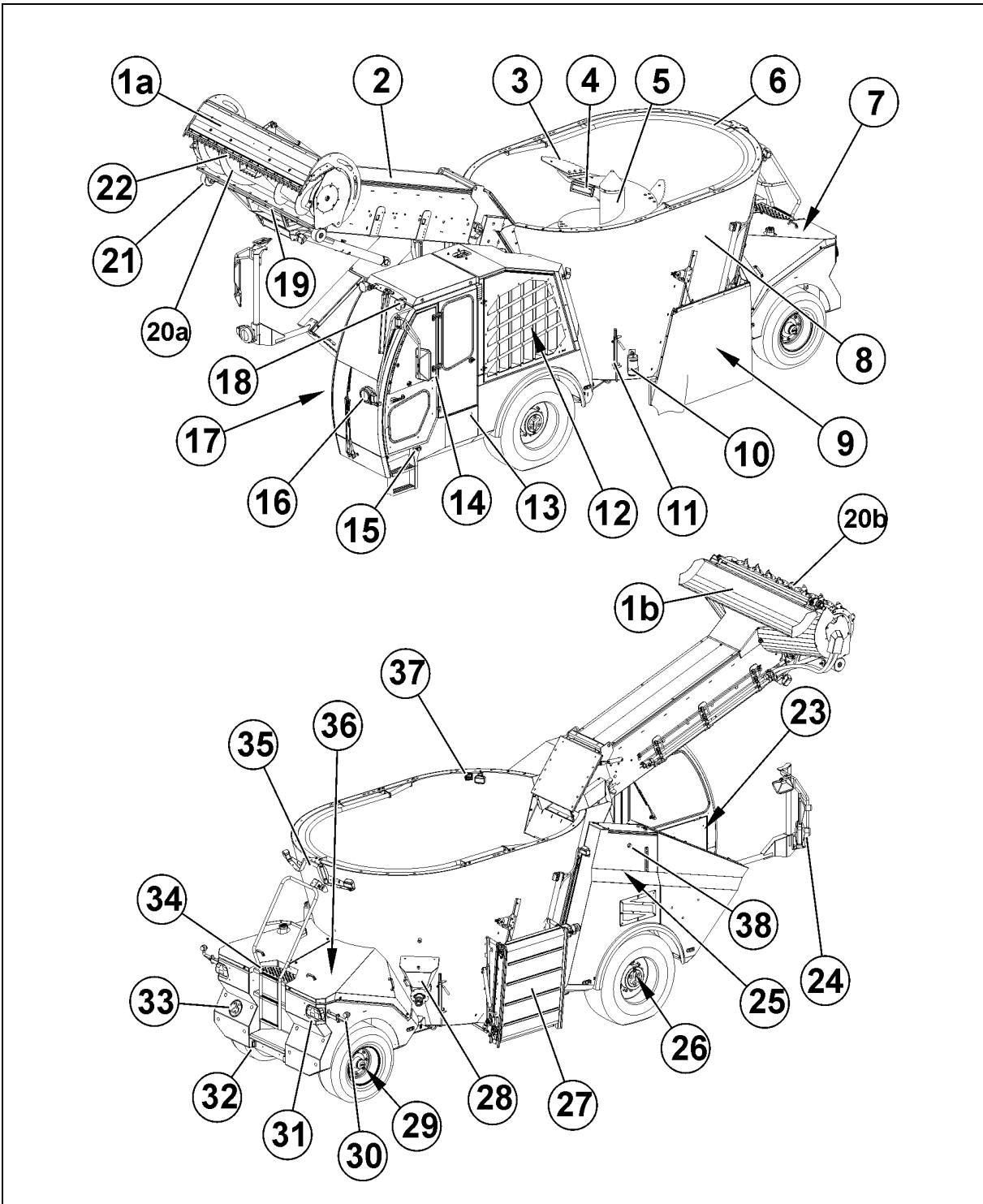

Fig. 1

- | | |
|--|--|
| (1a) Cutting unit * / ** | (18) Work lights |
| (1b) Milling drum protection ** | (19) Scraper bar |
| (2) Pick-up arm (conveyor duct with elevator conveyor) | (20a) Conveyor drum * |
| (3) Cutting knife | (20b) Milling drum with milling blades |

- | | |
|--|--|
| (4) Magnetic system * | (21) Supporting roller |
| (5) Mixing auger | (22) Fast-Cut cutting knives * |
| (6) Overflow ring * | (23) Central electrical system (relays) |
| (7) Fuel tank, electro-hydraulic control block * | (24) Outside mirror ** |
| (8) Mixing container | (25) Hydraulic oil tank with level indicator, electro-hydraulic control block, stop-cock for emergency lifting operation |
| (9) Discharge opening with dosage gate (behind protective apron **) | (26) Brake driving axle |
| (10) Gear lubricant oil compensating reservoir for mixer gearbox | (27) Side discharge conveyor * |
| (11) Counter-cutter | (28) Hydraulic feed hopper * |
| (12) Fresh air filter for driver's cabin, air filter for diesel engine, coolant compensating reservoir, combined cooler (charge air, coolant, hydraulic oil), windscreen washing water container | (29) Steering axle |
| (13) Battery main switch ** | (30) Clearance lamp ** |
| (14) Driver's cabin | (31) Multi-function light ** with rear and brake light, reversing light, indicator, side-marker lamp, reflector |
| (15) Side-marker light ** | (32) License plate light |
| (16) Headlight **, indicator ** | (33) Speed sign |
| (17) Diesel engine, hydraulic pumps, contamination indicator for hydraulic oil intake of feed pump, three-way cock for hydraulic chassis *, three-way cock for pick-up arm, chocks ** | (34) Platform with ladder |
| | (35) Rear-view camera ** |
| | (36) Starter batteries |
| | (37) Mixing container camera * |
| | (38) Contamination indicator for hydraulic oil return-flow filter |

* Optional extra

** Safety and protective device

2.2 Driver's cabin

- (1) Steering column
- (2) Steering wheel
- (3) Ignition and starter switch
- (4) Reversing gear for forward and reverse travel
- (5) Switch for parking and driving light

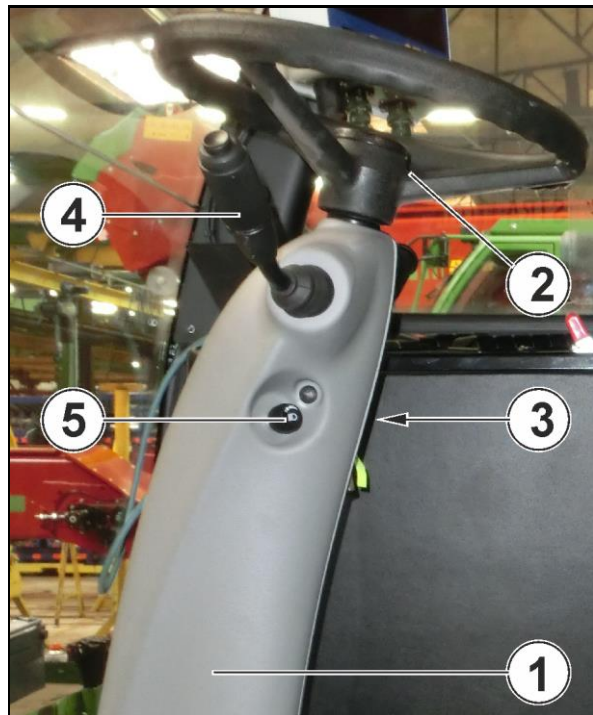

Fig. 2

- (6) Pedal of steering column adjustment
- (7) Left-hand brake pedal
- (8) Right-hand brake pedal
- (9) Accelerator pedal



Fig. 3

- (10) Control console
- (11) Manual throttle lever
- (12) Joystick
- (13) Terminal
- (14) Separate terminal of weighing device
- (15) Multi-function switch for indicator, dimmed and full headlights, headlight flasher, windscreen wiper and horn



Fig. 4

- (16) Driver seat
- (17) Socket (24 V)
- (18) Door window unlocking mechanism
- (19) Fuse box
- (20) Warning triangle
- (21) Emergency hammer



Fig. 5

- (22) Interior light
- (23) Heating controller
- (24) Fan regulator
- (25) Ventilation nozzles
- (26) Air circulation grid
- (27) Sunblind
- (28) Radio
- (29) Loudspeakers

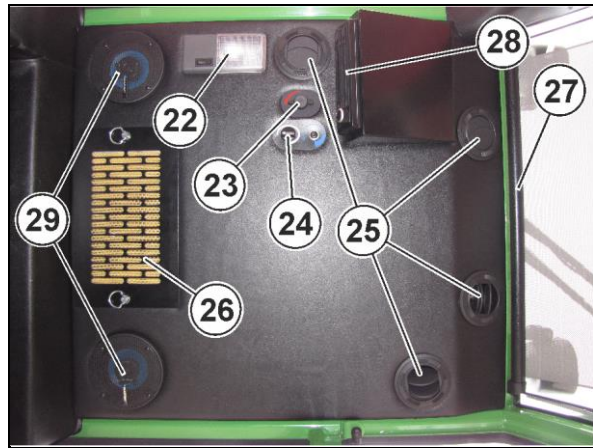

Fig. 6

2.3 Electrical system

2.3.1 Battery main switch

The battery main switch is mounted on the left-hand side of the driver's cabin.

- (1) **on**
electrical system connected with battery
- (2) **off**
electrical system disconnected from battery

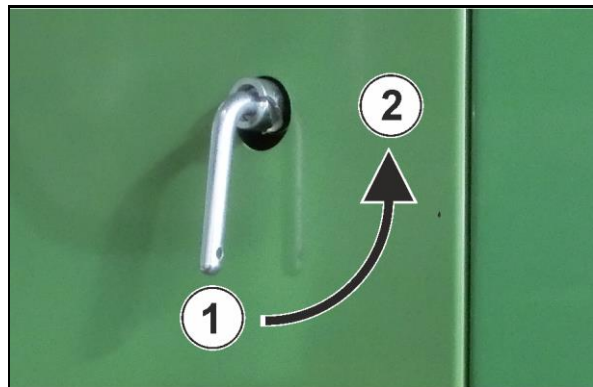

Fig. 7

2.3.2 Fuses

The fuses F1-F48 (1) and F50 (2) are mounted in the fuse box behind the driver seat (fold back rest forward!).

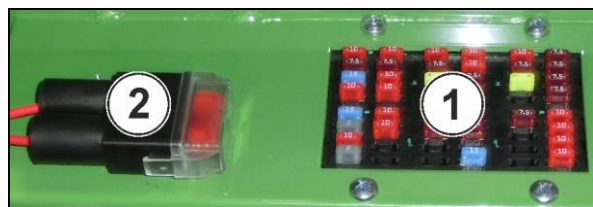

Fig. 8

The fuse F49 (3) is mounted at the diesel engine.

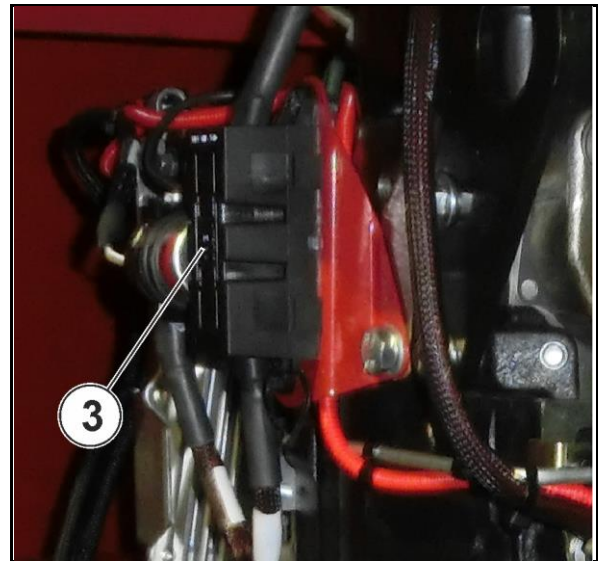

Fig. 9

F1 10A		F9 10A		F17 10A	ICN-V AG2	F25 10A	ICN-V AG3	F33 10A		F41 7.5A	
F2 7.5A		F10 7.5A		F18 7.5A		F26 10A		F34 7.5A		F42 7.5A	
F3 15A		F11 10A		F19 20A		F27 7.5A		F35 20A		F43 7.5A	
F4 10A		F12 10A		F20 7.5A		F28 7.5A		F36		F44 7.5A	
F5		F13 10A		F21 10A		F29 7.5A		F37 7.5A		F45 10A	
F6 2A	ICN-V	F14 10A		F22 10A		F30	Extra	F38 7.5A		F46 10A	
F7 10A		F15		F23 7.5A		F31 7.5A		F39 7.5A		F47 10A	
F8 2A		F16		F24 5A		F32		F40 7.5A	Extra 12V	F48 10A	
F49 100A				F50 50A							

Fig. 10

- | | | | |
|-----|---|-----|----------------------------------|
| F1 | Sensors I | F26 | Mixing auger |
| F2 | Weighing device / Terminal / Camera | F27 | Dosage gate |
| F3 | Rear axle / Optional extra | F28 | Indicator system |
| F4 | Side window wiper | F29 | Brake light |
| F6 | ICN-V | F30 | Optional extra |
| F7 | Ventilating fan / Ventilator / Heating | F31 | Mirror arm |
| F8 | Voltage transformer (24 V/5 V) | F33 | Socket, driver's cabin |
| F9 | Sensors II | F34 | Lighting, driver's cabin / Radio |
| F10 | Differential lock / Parking brake | F35 | Engine control unit |
| F11 | Hydraulic counter-cutters | F37 | Warning lights |
| F12 | Windscreen wiper / Horn | F38 | Radio |
| F13 | Reversing lights | F39 | Weighing device |
| F14 | Milling drum protection / Cutting unit / Mirror arm | F40 | Optional extra |
| F17 | ICN-V (output group 2) | F41 | Parking lights, left |
| F18 | Traction engine | F42 | Parking lights, right |

- | | | | |
|-----|-------------------------|-----|--------------------------------------|
| F19 | Engine control unit | F43 | Dimmed headlights, left |
| F20 | Mirror heating | F44 | Dimmed headlights, right |
| F21 | Driver seat | F45 | Full headlights |
| F22 | Side discharge conveyor | F46 | Work light, front |
| F23 | Central lubrication | F47 | Work light, middle |
| F24 | Elevator conveyor | F48 | Work light, rear |
| F25 | ICN-V (output group 3) | F49 | Diesel engine, intake air preheating |
| | | F50 | Ignition |

2.3.3 Relays

The relays (1) are situated in the central electrical system on the right-hand side of the driver's cabin.

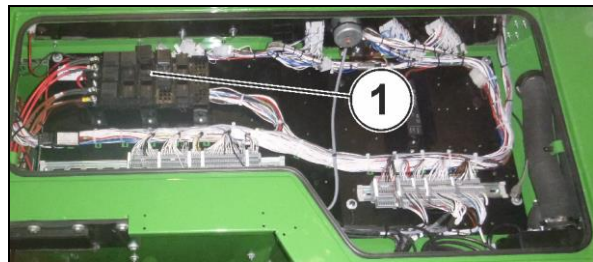

Fig. 11

X1 30 • 30 •	K1 ICN - V1_1	K4 ICN - V1_4	K7 	K10 	K13 24V/12V	K16
X2 15 • 	K2 ICN - V1_2	K5 	K8 	K11 	K14 	K17
X3 31 • 31 •	K3 ICN - V1_3	K6 	K9 	K12 	K15 	K18

Fig. 12

- | | | | |
|----|-------------------|-----|--|
| X1 | Supply | K8 | Lift milling drum protection/cutting unit / Retract mirror arm |
| X2 | Ignition positive | K9 | Brake light |
| X3 | Ground | K10 | Wiping / Washing interval |
| K1 | ICN-V 1_1 | K11 | Windscreen wiper, top |
| K2 | ICN-V 1_2 | K13 | Radio |
| K3 | ICN-V 1_3 | K14 | Lower milling drum protection/cutting unit / Extend mirror arm |
| K4 | ICN-V 1_4 | K15 | Reversing lights |
| K5 | Light | K16 | Elevator conveyor |
| K6 | Parking light | K17 | Side discharge conveyor / Elevator conveyor |
| K7 | Indicator system | | |

2.4 Hydraulic system of machine

2.4.1 Stop-cocks

The three-way cocks for the pick-up arm (1) and the hydraulic chassis (optional extra) (2) are mounted in the engine compartment.



Fig. 13

The stop-cock (3) for the emergency lifting operation of the pick-up arm is best accessible after removal of the right-hand front cover (4).



Fig. 14

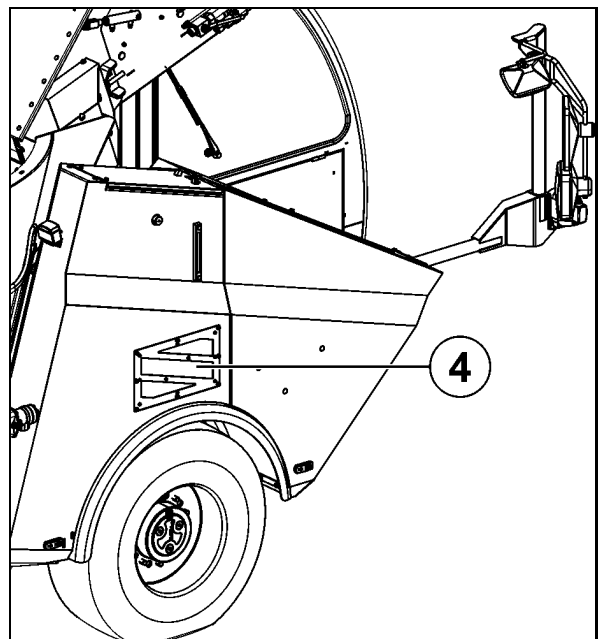

Fig. 15

2.5 Type plate



The complete marking is treated as a document and must not be altered or made unrecognizable.

- (1) Type plate with CE symbol
- (2) Vehicle/Machine ID number (embossed into the frame)

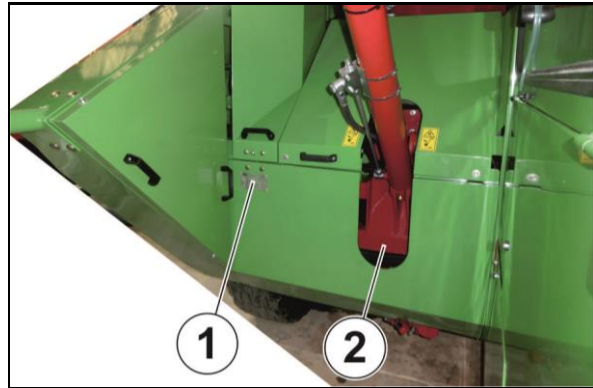

Fig. 16

Information on the type plate:

- (1) Manufacturer
- (2) CE symbol
- (3) Vehicle/Machine ID number
- (4) Type
- (5) Empty weight [kg]
- (6) Gross vehicle weight rating [kg]
- (7) Admissible tongue load/front axle load [kg]
- (8) Admissible rear axle load [kg]
- (9) Approval number
- (10) Year of manufacture
- (11) Rated speed [min^{-1}]
- (12) Admissible hydraulic pressure [bar]
- (13) Maximum admissible speed [km/h]

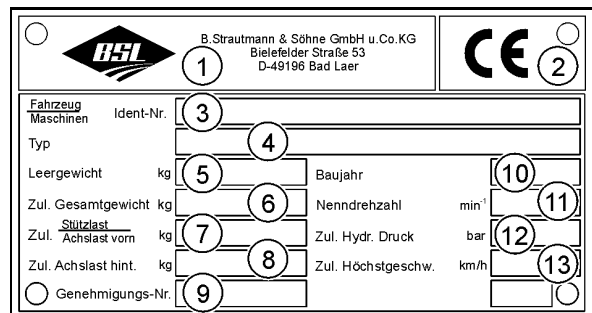

Fig. 17

2.6 Technical data



Please also observe all further operating instructions and user manuals included in the delivery!

		Sherpa 1201	Sherpa 1401
Total length	m	8.25	8.25
Total width			
with one-sided discharge	m	2.52	2.52
with two-sided discharge	m	2.62	2.62

		Sherpa 1201	Sherpa 1401
Total height			
with lowered pick-up arm	m	2.54	2.79
Wheelbase	m	3.86	3.86
Outside wheel width			
front	m	2.31	2.31
rear	m	1.94	1.94
Turning radius			
outside front	m	5.26	5.26
outside rear	m	5.73	5.73
inside	m	1.43	1.43
Usable mixing capacity	m ³	12.0	14.0
Picking-up width	m	2.00	2.00
Picking-up height	m	4.00	4.00
Diameter of milling drum/conveyor drum	m	0.61	0.61
Elevator width	m	0.58	0.58
Dead weight (approx.)	kg	10 200	10 300
Engine output at 2200 min ⁻¹	kW / PS	106 / 144	106 / 144
Max. torque at 1400 min ⁻¹	Nm	556	556
Fuel tank	l	140	140
Engine oil tank	l	8.5	8.5
Hydraulic oil tank	l	270	270
Coolant tank	l	19	19
Electrical system	V	24	24
Battery (2 x)	V / Ah	12 / 110	12 / 110
Tyres			
front	–	385/65 R22.5 161 F	385/65 R22.5 161 F
rear	–	355/60 R18 MPT 142 J	355/60 R18 MPT 142 J
Tyre pressure			
front	bar	9.0	9.0
rear	bar	5.0	5.0
Maximum admissible speed			
1 travelling mode	km/h	15	15
2 travelling modes	km/h	25	25

Figures, technical data and weights may change due to technical development and are not binding for delivery.

3 Safety instructions

This chapter contains important information for the user and the operator on how to operate the machine in a safety-conscious and trouble-free way.



Observe all safety instructions included in these operating instructions!

Most accidents are caused by non-observance of simplest safety rules.

By observing all safety instructions included in these operating instructions, you help to prevent accidents.

3.1 Correct use

The machine

- is designed for picking-up, charging, chopping, mixing, transport and discharge of all types of silage and normal fodders used in keeping livestock if the dry substance content of the total mixture is more than 30 % at any time of the mixing process,
- must not be charged otherwise than by means of
 - the pick-up arm,
 - the hydraulic feed hopper at the mixing container (optional extra),
 - a tractor with a front loader,
 - a yard or wheeled loader.

3.2 Safety-conscious working

The machine complies with the safety-related requirements and state of the art. When using the machine, risks and impairments might yet arise:

- for life and limb of the operator or third parties,
- for the machine itself,
- to other material assets.

For the safety-conscious operation of the machine, please observe:

- these operating instructions, in particular:
 - the basic safety instructions, the activity-related safety instructions and the instructions what to do,
 - the instructions regarding correct use.
- the warning signs on the machine,
- the general national occupational safety, accident prevention and environmental protection rules,
- the national road traffic regulations when carrying out transport journeys.

Only operate the machine in perfect safety-related condition.

3.3 Organisational measures



The operating instructions:

- must always be kept at the machine's place of operation,
- must always be easily accessible for operating and maintenance staff.

3.3.1 User's obligation

The user is obliged:

- to observe the general national occupational safety, accident prevention and environmental protection rules,
- to exclusively have staff operating the machine who:
 - know the basic occupational safety and accident prevention regulations,
 - have been instructed how to operate the machine,
 - have read and understood these operating instructions.
- to keep all warning signs attached to the machine in legible condition,
- to replace any damaged warning signs,
- to provide the necessary personal protective equipment such as protective goggles, work gloves according to DIN EN 388, safety footwear, protective clothing, skin protectant, etc.

3.3.2 Operator's obligation

Any members of staff charged to operate the machine are obliged:

- to acquaint themselves with the machine before starting operation,
- to acquaint themselves with the following regulations and to observe them during work:
 - the general national occupational safety, accident prevention and environmental protection rules,
 - the chapter "Basic safety instructions", page 26,
 - the chapter „Warning and instruction signs“, page 33, and the warning signs when operating the machine,
 - the chapters of these operating instructions which are important for the tasks assigned to them.

If the operator notices that a device is not in a sound safety-related condition, the operator shall be obliged to immediately eliminate this defect. If this is not part of the operator's scope of tasks or he/she lacks adequate expert knowledge, the operator shall be obliged to report this defect to his/her superior or to the user.

3.3.3 Qualification of operator



Only trained and instructed staff is allowed to operate the machine. The user must clearly define the responsibilities of the members of staff for operation, service and maintenance.

A person to be trained must be supervised when operating the machine.

The operator is only allowed to carry out such work as specified in these operating instructions which is not marked as "Shop work".

Only authorised workshops are allowed to carry out work on the machine which requires special expert knowledge. Authorised workshops have qualified staff and adequate means (tools, lifting and supporting equipment) at their disposal to carry out this work properly.

This applies to any work:

- which is not mentioned in these operating instructions,
- which is marked as "Shop work" in these operating instructions.

3.4 Product safety

3.4.1 Hazardous areas and dangerous spots

The hazardous area is the area within and/or in the vicinity of a machine, in which the safety or health of people might be impaired.



People are not allowed in the hazardous area:

- when the diesel engine is running,
- if the machine is not secured against accidental starting and rolling.

Only if no people are within the hazardous area of the machine, is the operator allowed to:

- move the machine,
- initiate hazardous movements of movable components, e.g. lifting or lowering the pick-up arm,
- set movable machine parts from transport to working position and from working to transport position,
- power working tools.

Within the hazardous area, risks occur at dangerous spots which cannot be completely eliminated due to the operational safety of the machine. The risks exist permanently or may occur unexpectedly.

Dangerous spots are marked by warning signs attached to the machine, which warn about existing residual risks.

In these operating instructions, activity-related safety instructions mark the existing residual risks.

Risks may arise:

- due to work-related movements of the machine and its working tools,
- due to substances or foreign objects blown out of the machine,

- due to accidental lowering of the lifted machine/of lifted machine parts,
- due to accidental starting and rolling of the machine.

3.4.2 Safety and protective devices

- Only operate the machine when all safety and protective devices are properly fixed and in fully operable condition.
Defective or removed safety and protective devices might cause dangerous situations.
 - Check all safety and protective devices for visible damage and functional ability before starting the machine.
- See also chapter "General overview of machine", page 12!

3.4.3 Structural alterations

- Vehicles provided with an official operating license or vehicle-linked devices and equipment provided with an official operating license or a road traffic license according to the road traffic regulations must be in the condition specified by that license.
- You are only allowed to carry out structural alterations, extensions or modifications on the machine with the prior written consent of the manufacturer.
- In case of non-authorized structural alterations, extensions or modifications:
 - the declaration of conformity and the CE symbol of the machine will become invalid,
 - the operating license according to national and international regulations will become invalid.
- Exclusively use original parts or modification and accessory parts approved by the manufacturer such that:
 - the declaration of conformity and the CE symbol of the machine will remain unaffected,
 - the operating license according to national and international regulations will remain unaffected,
 - perfect functioning of the machine will be ensured.
- The manufacturer will not assume any liability for damage resulting from:
 - unauthorized alterations of the machine,
 - non-approved modification and accessory parts,
 - welding and drilling work on load-bearing parts of the machine.

3.4.4 Spare and wearing parts, auxiliary materials

Immediately replace machine parts which are not in perfect condition.

Exclusively use original parts of the manufacturer or parts approved by the manufacturer such that the operating license according to national and international regulations will remain unaffected. If spare and wearing parts produced by third-party manufacturers are used, their stress-related and safety-conscious design and production will not be ensured.

The manufacturer will not assume any liability for damage resulting from the use of non-approved spare and wearing parts or auxiliary materials.

3.4.5 Warranty and liability

As a basic principle, our "General Sales Terms and Delivery Conditions" shall apply. They have been handed over to the user upon conclusion of contract at the latest.

Any warranty and liability claims in case of personal injury and material damage will be excluded if they are due to one or several of the following reasons:

- improper use of the machine,
- improper assembly, commissioning, operation and maintenance of the machine,
- operation of the machine, the safety devices being defective or the safety and protective devices having not been properly installed or being not serviceable,
- non-observance of the instructions included in the operating instructions referring to commissioning, operation and maintenance,
- unauthorized structural alterations on the machine,
- insufficient inspection of machine parts which are subject to wear,
- improperly effected repairs,
- disasters due to foreign objects and force majeure.

3.5 Basic safety instructions

Basic safety instructions:

- shall, as a basic principle, apply to the safe operation of the machine,
- are summarized in the subsections below.

3.5.1 General safety and accident prevention instructions

- **Risk of injury due to movements of the machine or its working tools!**

Before carrying out any work for which the driver's cabin must be left, it is imperative to

 - secure the machine against accidental starting, rolling and actuation:
 1. Switch the parking brake on.
 2. Turn the diesel engine off.
 3. Pull the ignition key out.
 4. Lock the driver's cabin.
 5. Additionally secure the machine against rolling on uneven ground or downhill gradients by means of the chocks.
 - secure lifted machine parts / the lifted machine against accidental lowering.

► See also chapter "Secure pick-up arm against accidental lowering", page 80!
 - Observe the general national safety and accident prevention regulations in addition to the safety instructions included in this chapter!
 - Wear your personal protective equipment when carrying out work on the machine!
 - Observe the warning and instruction signs attached to the machine. They provide important information for the safe and trouble-free operation of the machine!
 - Observe the activity-related safety instructions included in the other chapters in addition to the basic safety instructions included in this chapter!
 - Make sure that people leave the hazardous area of the machine, before moving or starting the machine! Particularly be aware of children!
 - Always ensure a clear view through all windows!
 - Carrying passengers and transport of objects are not allowed on the machine!
 - Adapt your driving such that you have always safe control over the machine!
- Consider your personal abilities as well as the road, traffic, visibility and weather conditions and the driving characteristics of the machine.

- Avoid sudden changes of direction, in particular when travelling uphill and downhill and when traversing hills!
- Beware when driving in reverse gear!
- Never leave the machine unattended with the diesel engine running!
- It is not allowed to drill holes, to widen existing holes or to carry out welding work on load-bearing parts such as frame and chassis.
- Use a mobile service platform with ladder for all work at heights!

Use of machine

- Acquaint yourself with all mechanisms and operating elements of the machine and their functions before starting work! During operation it will be too late.
- Check the travelling height of the hydraulic chassis (optional extra) before each use.
- Wear close-fitting clothing! Loose-fitting clothing increases the risk of becoming entangled in or wound up at drive shafts!
- Check the machine for its road and operational safety before each use.
- Adjust the mirrors and the rear-view camera such that there is sufficient visibility of the hazardous area around the machine.
- The fodder mixing wagon is only allowed to be operated by one person!
- Before operating the machine, make sure that third persons / animals leave the machine's hazardous area!
- Before reversing, make sure that there are no people, animals or objects behind or closely beside the machine.
- Start the machine only if all protective devices have been installed and are in protective position!
- Do not block any operating elements (levers, key buttons, etc.), which initiate dangerous movements, such as folding, swivelling or sliding operations! The movement must automatically stop as soon as the operating element is released.
- Fill the fodder mixing wagon only by means of the pick-up arm, a tractor equipped with a front loader or by means of a wheeled loader!
- Observe the maximum load and the admissible axle and tongue loads of the machine! Run the machine being only partly filled if necessary.
- People are not allowed:
 - above the fodder mixing wagon, e.g. to fill the mixing container manually from a silo or a hayloft! People who are standing above the fodder mixing wagon risk to fall into the mixing container,
 - to climb onto the top edge of the mixing container,
 - to enter or reach into the mixing container,
 - to travel as passengers on the machine!
- It is not allowed to climb onto the pick-up arm or to use it as a lifting device!
- Dose additional fodder additives (e.g. mineral feed) or other bulk materials through the feed hopper (optional extra)!
- Risk of crushing when opening and closing the discharge doors. Before opening or closing the discharge door(s), make sure that people and animals leave the hazardous area!
- Never reach into the mixing container through a discharge opening::
 - as long as the engine is running,
 - as long as the discharge door has not been secured against accidental lowering!

- People are not allowed:
 - within the operating/hazardous area of the machine,
 - within the discharge area of the machine,
 - within the turning and swivelling range of movable machine parts,
 - beneath lifted and unsecured movable machine parts!
- Powered (e. g. hydraulically) movable machine parts have crushing and shearing zones!
- You are only allowed to operate powered machine parts if there are no people within the machine's hazardous area!
- Before leaving the cabin you must:
 - lower the milling drum protection/the cutting unit to its end position,
 - lower the pick-up arm to its end position,
 - apply the parking brake,
 - turn the engine off,
 - pull the ignition key out.Lock the cabin when leaving.
- Safely support folded-up covers before standing underneath them!
- Disconnect the electrical system from the battery by means of the battery main switch after each use. Risk of fire!

Travelling mode

- Never start or operate the diesel engine without battery. This will destroy the three-phase generator.
- Acquaint yourself with the machine-specific characteristics before road travels, in particular
 - with the rear axle steering:

The machine is very easily manoeuvrable, it responds very quickly to each steering movement!

The rear swings out sideways when cornering!

Practice cornering (forward and reverse) in the yard or on an empty square if necessary until you have safe control over the machine.
 - with the operating levers at the steering column:

The indicator is actuated by means of the right-hand lever!

The left-hand lever is the reversing gear for forward and reverse travel!

When accidentally switching over the left-hand lever while travelling, the machine will immediately stop!
 - with the double brake pedal:

During road journeys, only use your right leg to actuate the accelerator pedal and the right-hand brake pedal!

Only actuate the left-hand brake pedal by means of your left leg to prevent the machine from rolling during silage pick-up.
- For travelling on public roads
 - the machine must be licensed for travelling on public roads,
 - the driver must have a valid driving licence.
- Transport journeys are only allowed with traffic-related equipment being completely mounted and in fully operable condition!

- Transport journeys are only allowed with lowered pick-up arm and closed milling drum protection/lowered cutting unit! Lower the pick-up arm such that the maximum distance between the scraper bar and the ground is 25 cm.
- Observe the respective national road traffic regulations when carrying out transport journeys on public roads!
- Before carrying out transport journeys, check:
 - the lighting system for damage, proper functioning and cleanliness,
 - the brake and hydraulic system for visible defects,
 - whether the parking brake has been completely released,
 - the brake system for proper functioning!
- Avoid sudden changes of direction, in particular when travelling uphill and downhill and when traversing hills!
- Drive slowly on uneven ground! Too strong up-and-down movements may interrupt the seat sensor connection in the driver seat and immediately stop the machine.
- Always keep the cabin door closed when driving!
- Set all movable machine parts to transport position and secure them before carrying out transport journeys! Use the transport locks provided for this purpose!
- Adapt your travelling speed to the conditions prevailing at the time!
- Switch the work lights off when travelling on roads!
- Behaviour in case of a road accident:
 1. Park the machine at a safe distance from the moving traffic if possible.
 2. Switch the warning lights on.
 3. Switch the parking brake on.
 4. Turn the diesel engine off.
 5. Pull the ignition key out.
 6. Lock the driver's cabin.
 7. Disconnect the electrical system from the battery by means of the battery main switch.
 8. Secure the scene of the accident. Position the warning triangle at an adequate distance.
 9. If people are injured:
 - 9.1 Immediately call the emergency services.
 - 9.2 Provide first aid.

3.5.2 Hydraulic system

The hydraulic system is under high pressure!

- Only an authorised workshop is allowed to carry out work on the hydraulic system!
- Ensure that the hydraulic hoses and pipes never bend or chafe!
- Hydraulic hose pipes must be replaced in case of visible defects, damage and ageing! Only use original hydraulic hose pipes!
- The period of use of the hydraulic hose pipes should not exceed six years (including a maximum possible shelf life of two years).
- Never try to block leaking hydraulic hose pipes with your hand or fingers! Immediately contact an authorized workshop if a leak is suspected.

Hydraulic oil squirting out under high pressure may enter the skin and the body and cause serious injuries.

If injuries caused by hydraulic oil occur, immediately contact the medical services. Risk of infection!

- Never try to detect leakage points with your bare hands. Risk of serious infection! Use appropriate means when trying to locate leakage points (cleaning sprays, special leak detector spray)!
- Overcoating of hydraulic hose pipes is not allowed!

3.5.3 Electrical system

- Only an authorised workshop is allowed to carry out work on the electrical system (shop work)!
- Never fit the machine with additional work lights without authorisation! The manufacturer will not assume any liability or warranty for subsequent damage on the electrical system.
- Before carrying out any work on the electrical system, disconnect the electrical system from the battery! Use the battery disconnecter for this purpose.
- Only use the specified fuses. When using bigger fuses, the electrical system may be destroyed. Risk of fire!
- Avoid sparking and open fire in the vicinity of the battery! Risk of explosion!
- As a basic principle, disconnect all electrical / electronic plug-in connections before carrying out welding work on the machine!
- Ensure correct order when connecting and disconnecting the battery:
 - connection: first connect the plus pole, then the minus pole,
 - disconnection: first disconnect the minus pole, then the plus pole!
- Always cover the plus pole of the battery as required. Risk of explosion in case of accidental ground!
- The machine can be equipped with electronic components and parts, the functioning of which may be affected by electromagnetic emissions of other devices. Such interferences may be a risk to people if the following safety instructions are not observed:
 - In case of a retrofitting of electrical devices or components into the machine and their connection to the on-board electrical system, the user must check on his own responsibility whether the retrofitted parts interfere with the vehicle electronics or other components.
 - Ensure that the retrofitted electrical and electronic components comply with the EMC directive as amended from time to time and bear the CE symbol!

3.5.4 Diesel engine

- Only an authorised workshop is allowed to carry out work on the diesel engine, to change the engine oil, to replace the filters, etc.! Otherwise, the manufacturer will not assume any warranty or liability for damage.
- Never start the diesel engine in non-ventilated or closed locations. Risk of poisoning due to exhaust gases!
- Never open the engine cowling when steam or cooling agent is escaping. Risk of scalds or burns! Let the diesel engine cool down.
- Never spill service fluids over hot engine parts. Risk of fire or explosion! Let the diesel engine cool down and be careful when handling service fluids.
- When working in the engine compartment: Prevent your clothes or hair from becoming caught up in rotating engine parts. Roll up sleeves, tie up your hair!

3.5.5 Brake system

- Immediately stop the machine in case of failure of the brake system. Have the failure promptly remedied!
- Only authorized workshops or qualified personnel are allowed to carry out adjustment and repair work on the brake system!
- Have the brake system regularly and thoroughly checked!
In order to maintain the operational safety, the wheel brakes must always be properly adjusted.
- Before carrying out any work in the brake system:
 - safely park the machine and secure it against accidental rolling (chocks),
 - secure the lifted machine/machine parts against accidental lowering!
- Especially beware when carrying out welding and drilling work and work involving open fire in the vicinity of brake lines!
- As a basic principle, test the brakes after any adjusting and maintenance work on the brake system!

3.5.6 Axles

As a basic principle, never overload the axles. Overloading of axles reduces the service life of the axle bearings and causes damage to the axles.

Therefore avoid:

- overloading of the machine,
- bumping into curbs,
- exceeding the speed limit,
- mounting wheels of wrong inserting depth,
- mounting wheels and tyres of wrong dimensions.

3.5.7 Tyres

- Only qualified personnel equipped with appropriate fitting tools is allowed to carry out repair work on tyres and wheels! Mounting of wheels and tyres requires sufficient know-how and appropriate tools.
- Safely park the machine and secure it against accidental lowering and rolling (parking brake, chocks) before carrying out any work on the tyres!
- Place the lifting device at the marked application points.
- Use lifting equipment suitable and approved for the machine's weight with sufficient lifting power.
- Deflate the tyre before removing it!
- Regularly check the tyre pressure!
- Observe the maximum admissible tyre pressure. Risk of explosion in case of excessive pressure!
- Keep to the side of the wheel when refilling the tyres! An inflation hose with an approximate length of 1.5 m makes work easier.
- Retighten all fastening screws and nuts according to the manufacturer's specifications!

3.5.8 Service and maintenance of machine

- Carry out the required service and maintenance work on the machine in due time!
- Secure the machine against accidental starting and rolling before carrying out any service or maintenance work on the machine!
- Existing mechanical, hydraulic, pneumatic and electrical or electronic residual energies may cause accidental machine movements!
Beware of existing residual energies in the machine when carrying out maintenance work. Warning signs mark the components with residual energies.
- Risk of injuries caused by the sharp-edged cutting knives of the mixing auger(s). Wear your personal protective equipment (protective gloves, safety footwear), when carrying out maintenance work on the cutting knives of the mixing auger(s)!
- Keep sufficient safe distance to hot surfaces / components.
- Fix larger assemblies carefully to lifting equipment and secure them before replacing larger assemblies!
- Regularly check screws and nuts for tightness! Retighten loosened screws and nuts!
- Secure the lifted machine or lifted machine parts against accidental lowering before carrying out service or maintenance work on the machine!
- Use appropriate equipment and gloves when replacing working tools with blades!
- Never open protective devices,
 - when the machine is powered,
 - as long as the engine is running,
 - when the ignition key is in the machine,
 - when the machine is not secured against accidental rolling by means of the parking brake and/or the chocks.
- After finishing maintenance work, check the safety and protective devices for proper functioning! Immediately replace missing or defective protective devices!
- When using electrical tools, the connecting cables must not be moved over sharp-edged cutting knives!
- Immediately remove fresh oil stains by means of binding agents. Risk of slipping!
- Dispose of oils, greases and filters properly!
- Properly handle and dispose of substances and materials used for cleaning the machine, especially:
 - when working on lubrication systems and devices,
 - when carrying out cleaning work with solvents!
- Never clean the windows using fuel, paint thinner or similar. This may cause damage to the wiper blades.
- Disconnect the generator and battery cable and unplug the computers, before carrying out electrical welding work on the machine!
- Spare parts must at least comply with the specified technical standards of the manufacturer! This is guaranteed when using original parts!

3.6 Warning and instruction signs



The following warning and instruction signs are attached to the machine:

- Warning signs: They mark dangerous spots on the machine and warn about residual risks, which cannot be completely eliminated due to the machine's operational safety.
- Instruction signs: They include information referring to proper use of the machine.

Keep these signs always in a clean and clearly legible condition! Replace illegible signs. Order the warning and instruction signs according to their order number:

- from the dealer,
- directly via the Strautmänn spare parts warehouse, phone: + 49 (0) 5424 802-30.

3.6.1 Warning signs

A warning sign consists of 2 pictographs:

(1) Pictograph for description of risk

The pictograph shows the pictographic description of the risk, surrounded by a triangular hazard symbol.

(2) Pictograph how to avoid the risk

The pictograph shows the pictographic instruction how to avoid the risk.

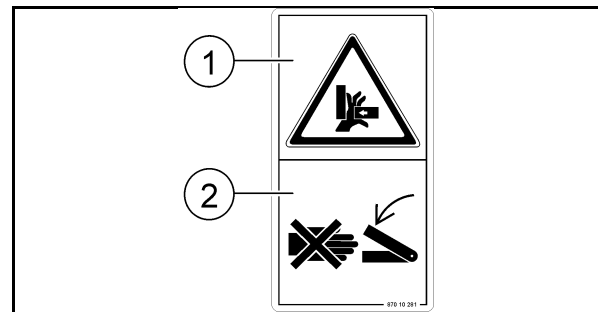
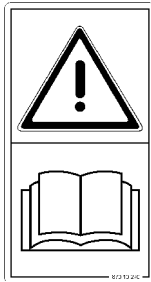
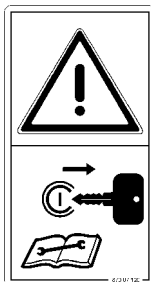
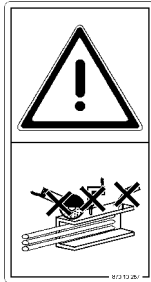



Fig. 18

Explanation of warning signs

The following list includes:

- in the right-hand column all warning signs attached to the machine,
- in the left-hand column the following details referring to the warning sign on the right-hand side:
 - the order number.
 - the description of risk, e. g. "Risk of crushing fingers or hand due to accessible movable machine parts!"
 - the consequences in case of non-observance of the instruction(s) how to avoid the risk, e. g. "This risk may cause most serious injuries involving loss of limbs."
 - the instruction(s) how to avoid the risk, e. g. "Never reach into the dangerous spot as long as the tractor engine is running with the propeller shaft coupled/the hydraulic/electronic system connected. Make sure that people leave the hazardous area of the machine before moving machine parts."

Order number and explanation	Warning signs
<p>87010270</p> <p>Please read and observe the operating and safety instructions before commissioning!</p>	
<p>87007120</p> <p>Risks when carrying out work on the machine such as mounting, adjusting, trouble-shooting and maintenance, due to accidental starting of the machine!</p> <p>This risk may cause most serious injuries or even death.</p> <ul style="list-style-type: none"> Secure the machine against accidental starting before carrying out any work on the machine. Read and observe the instructions in the respective chapters in the operating instructions depending on the work to be carried out. 	
<p>87010287</p> <p>Dangerous situations may occur if load-bearing parts break due to mechanical work on frame elements!</p> <p>This risk may cause most serious injuries or even death.</p> <p>As a basic principle, the following work is not allowed:</p> <ul style="list-style-type: none"> mechanical processing of the chassis, drilling at the chassis, boring up of existing holes at the chassis frame or at load-bearing parts, welding on load-bearing parts. 	
<p>87007108</p> <p>Risk to any part of the body of being crushed due to necessary work underneath unsecured, suspended loads or lifted machine parts!</p> <p>This risk may cause most serious injuries or even death!</p> <p>Activate the safety locking mechanism against accidental lowering of suspended loads or lifted machine parts before entering the hazardous area.</p>	
<p>87007117</p> <p>Risk to any part of the body of being drawn in or becoming entangled due to powered working tools!</p> <p>This risk may cause most serious injuries or even death.</p> <p>Never enter the mixing container as long as the diesel engine is running.</p>	

87007557

Risk to any part of the body of being drawn in or becoming entangled due to the rotating mixing auger(s)!

This risk may cause most serious injuries or even death.

Never enter the mixing container as long as the diesel engine is running!

87007122

Risk of electrical shock or burns due to accidental touching of electrical overhead lines or due to inadmissible approach to high-voltage overhead lines!

This risk may cause most serious injuries or even death.

Keep sufficient safe distance to high-voltage overhead lines.

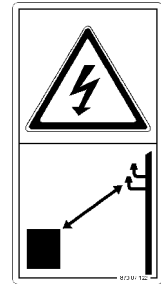

Nominal voltage	Safe distance to overhead lines
up to 1 kV	1 m
over 1 up to 110 kV	3 m
over 110 up to 220 kV	4 m
over 220 up to 380 kV	5 m
nominal voltage unknown	5 m

87007123

Risk due to hydraulic oil squirting out under high pressure, caused by leaking hydraulic hose pipes!

This risk may cause most serious injuries or even death if hydraulic oil squirting out under high pressure enters the skin and the body.

- Never try to block hydraulic hose pipe leaks with your hands or fingers.
- Read and observe the information included in the operating instructions before carrying out service and maintenance work on hydraulic hose pipes.

87007126

Risk to any part of the body of being rolled over by the machine due to accidental rolling of the machine parked in unsecured condition!

This risk may cause most serious injuries or even death.

Before parking the machine, secure it against accidental rolling by means of the parking brake and/or the chocks.



87007121

Risk of falling for passengers on treads or platforms!

This risk may cause most serious injuries or even death.

- It is not allowed:
 - to transport people as passengers on the machine,
 - to transport objects on the machine,
 - to climb onto travelling machines.
- Ensure that there are no passengers on the machine.



87012568

Risk of becoming entangled, wound up, being drawn in and risk of slipping, stumbling or falling if people fall from the top edge of the mixing container!

This risk may cause most serious injuries or even death.

Therefore, it is not allowed

- to stay above the mixing container.
- to bend over the mixing container.
- to enter the mixing container over the top edge of the container.



87010271

Risk to any part of the body of being crushed and/or risk of impact if people stand within the hazardous area of the machine!

This risk may cause most serious injuries or even death.

- People are not allowed within the hazardous area of the machine as long as the diesel engine and the machine have not been secured against accidental rolling.
- Make sure that people leave the hazardous area of the machine as long as the diesel engine and the machine have not been secured against accidental rolling.



87010276

Risk to any part of the body of being drawn in or becoming entangled due to powered working tools!

This risk may cause most serious injuries or even death.

- Keep sufficient safe distance to powered working tools.
- Ensure that people keep sufficient safe distance to powered working tools.



87010279

Risk of cuts for fingers and hands due to work on sharp / sharp-edged working tools!

This risk may cause most serious injuries including loss of limbs.

Observe the information in the operating instructions before carrying out work on sharp working tools.



87010280

Risk to hands or arms of being drawn in or becoming entangled in moving power transmission parts!

This risk may cause most serious injuries including loss of limbs.

Never open or remove protective devices as long as the diesel engine is running.



87010281

Risk to fingers or hands of being crushed due to accessible movable machine parts!

This risk may cause most serious injuries including loss of limbs.

Never reach into the hazardous area as long as the diesel engine is running.



87010283

Risk due to substances or foreign objects blown away from or out of the machine to people standing within the hazardous area of the machine!

This risk may cause most serious injuries to any part of the body.

- Keep sufficient safe distance to the hazardous area of the machine.
- Make sure that people keep sufficient safe distance to the hazardous area of the machine as long as the diesel engine is running.



870 07 552

Risk for people with pacemakers and implanted defibrillators due to magnetic fields!

The magnetic fields of the powerful permanent magnets may interfere with the functioning of active electronic implants such as pacemakers and defibrillators and cause harm to the health or even death of their wearers.

- Keep sufficient distance to the magnets if you wear a pacemaker or implanted defibrillator.
- Warn people with a pacemaker or implanted defibrillator to stay away from the magnets.

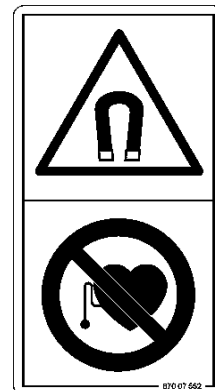

87007554

Risk of electric shock when touching the machine if a preheating device is improperly connected to the power supply!

This risk may cause most serious injuries or even death.

Make sure that the protective conductor ("ground") is connected to a residual current circuit breaker (RCCB) with max. 30 mA through all used components such as extension cables, timers, sockets, fixed cables.

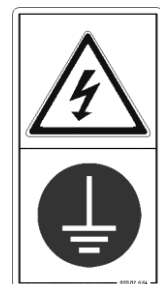

3.6.2 Instruction signs

An instruction sign consists of a pictograph:

(1) Pictograph including information about proper use of the machine.

The pictograph includes visual or descriptive information or information summarised in a table.

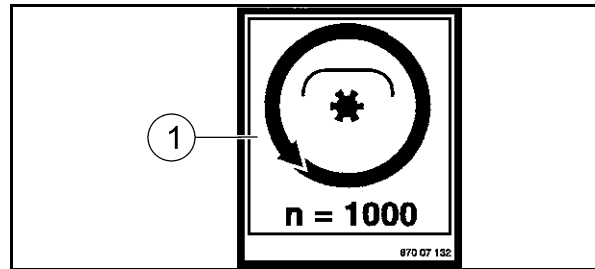

Fig. 19

Order number and explanation

Instruction signs

87007135

Observe the information for tyre maintenance included in the operating instructions.

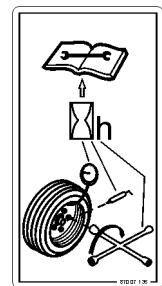

87706902

Use diesel fuel only in accordance with the current specifications of the engine manufacturer. Observe the service instructions.

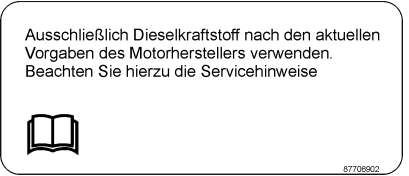

87010288

This pictograph illustrates fixing points for lifting equipment (jack).



877 06 091

The pictograph marks anchorage points for fixing slings for transport of the machine.



87007564

Read and observe the chapter Transport Journeys in the operating instructions before travelling on public roads!

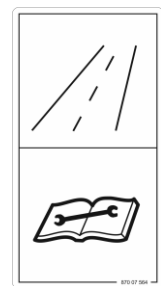

66307500

Close the cabin window before opening the radiator door!

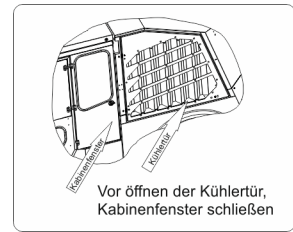

3.6.3 Placing of warning and instruction signs

The following figure illustrates the position of the warning and instruction signs on the machine.

Depending on the machine's equipment, more or less warning and instructions signs than shown here may be available.

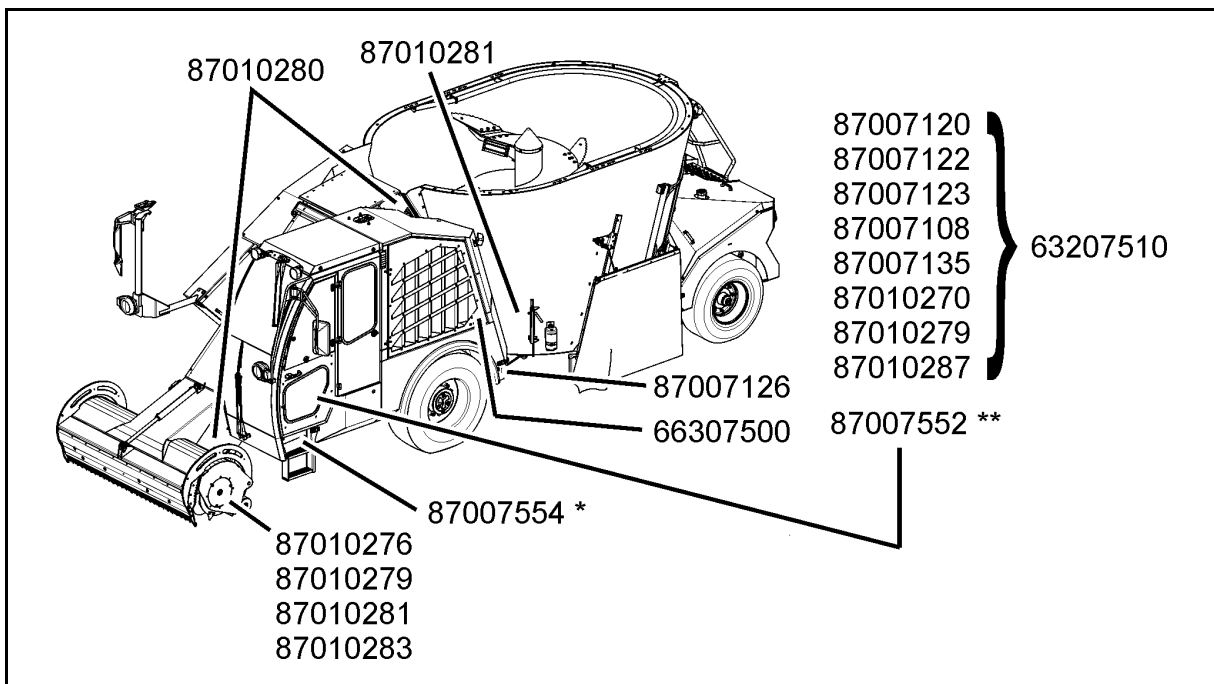

Fig. 20 * With preheating device (optional extra).

** With magnetic system (optional extra).

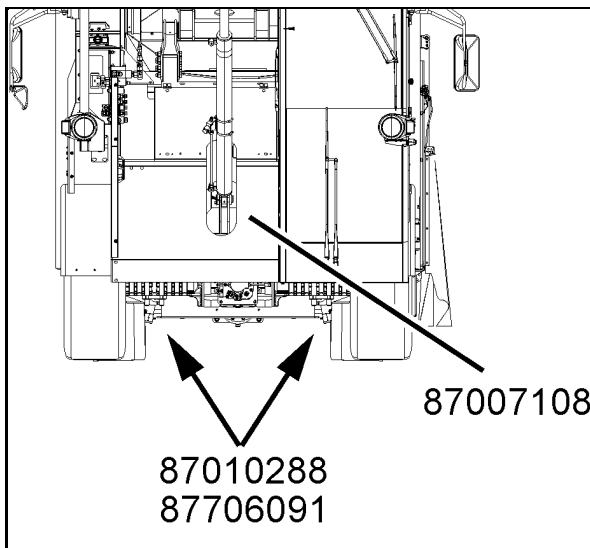

Fig. 21

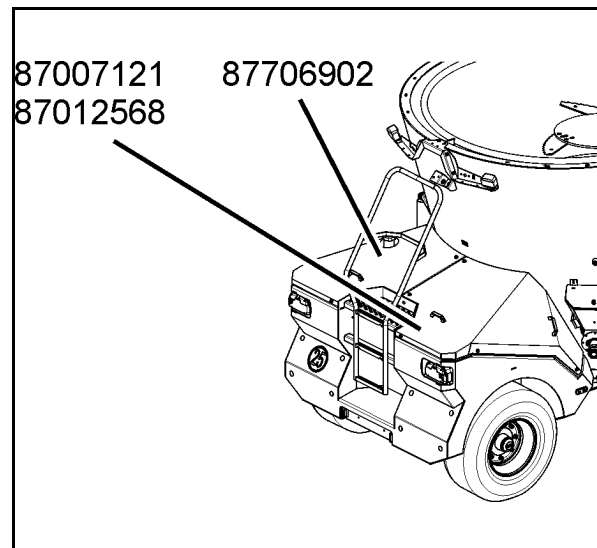

Fig. 22

Placing of warning signs at the discharge outlets

Side discharge

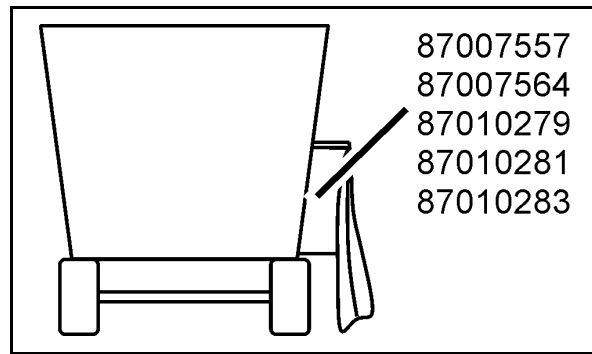

Fig. 23

Side discharge with side discharge conveyor

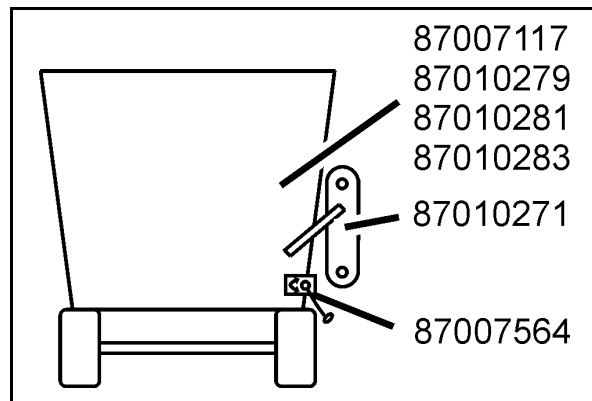

Fig. 24

3.7 Risks in case of non-observance of safety instructions and warning signs

Non-observance of the safety instructions and warning signs may:

- cause risk to people, environment and machine such as:
 - risk to people due to non-secured work areas,
 - failure of essential machine functions,
 - failure of specified methods for the use, service and maintenance of the machine,
 - risk to people due to mechanical and chemical effects,
 - threat to the environment due to leaking operating media.
- lead to invalidation of any claims for damages.

4 Commissioning

4.1 Open cabin door

From outside:

1. Unlock the door lock (1) by means of the door key.
2. Push the door latch (2) in and open the door.

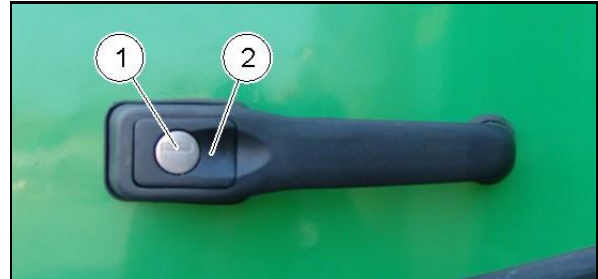

Fig. 25

From inside:

1. Push the door opening lever (1) down and open the door.

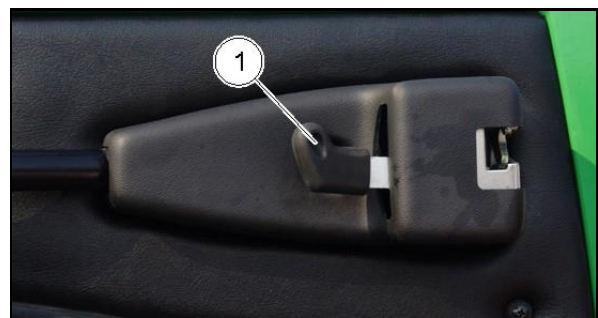

Fig. 26

4.2 Get in and out



Hold on to the two handles (1) when getting in and out!

Never hold on to the steering wheel when getting in and out! The steering wheel will not provide sufficient support and the steering column may be damaged.

Always get out backwards! Only then is there sufficient grip on the steps and handles.

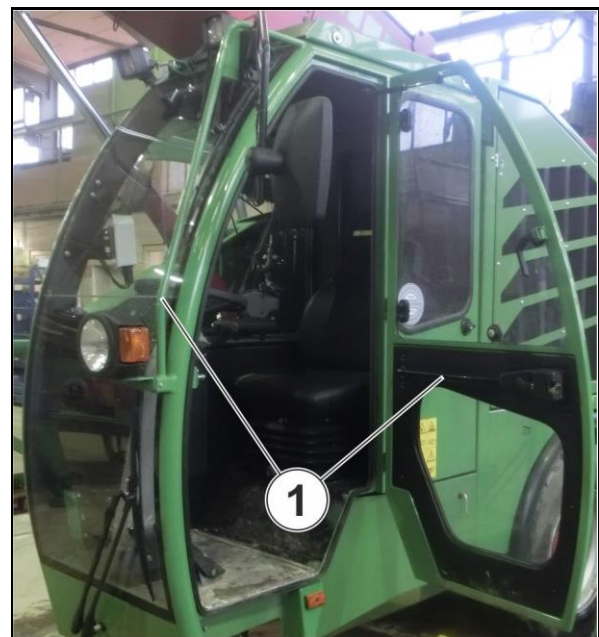

Fig. 27

4.3 Open door window

1. Turn the locking lever (2) and open the door window (1).
2. Swivel the door window until the open door window engages in the locking mechanism thus being secured against accidental slamming.



Fig. 28

4.4 Adjust driver seat



For safe and fatigue-free work: Adjust the driver seat such that all operating elements are within easy reach with your back against the back rest.

For trouble-free travelling: Adjust the driver seat to your weight to ensure that the safety switch in the driver seat will not hastily switch off the traction drive on uneven terrain and thus stop the machine.

DANGER



Risk of accident due to diverting attention!

Adjust the driver seat only when the machine is stationary, never during travel.

Adjust seat cushion:

Briefly push / pull the knob (1):

- Push = increase seat cushion.
- Pull = reduce seat cushion.

Adjust height of seat:

Turn the hand wheel (2).

→ The seat is lifted or lowered.

Adjust depth of seat:

1. Swivel the lever (3) outwards and move the seat forward or backwards.
2. Release the lever and move the seat on until the seat locking mechanism engages.

Adjust inclination of back rest:

1. Relieve the back rest and lift the lever (4).
2. Release the lever as soon as the inclination of the back rest has been properly adjusted.

Adjust lumbar support:

Relieve the back rest and turn the hand wheel (5) to adjust the effect of the lumbar support.

Switch horizontal cushioning on / off:

Move the lever (6) forward or backwards:

- Lever forward = switch horizontal cushioning on,
- Lever backwards = switch horizontal cushioning off.



Fig. 29

4.5 Adjust steering wheel position

DANGER



Risk of accident due to diverting attention!

Adjust the position of the steering wheel only when the machine is stationary, never during travel.

CAUTION



Risk of impact or crushing and damage to the steering column adjustment due to the steering column rebounding unbraked!

Hold the steering wheel firmly with both hands, before unlocking the steering column adjustment by means of the pedal.

1. Hold the steering wheel with both hands.
2. Floor the pedal (1) of the steering column adjustment mechanism and keep the pedal pressed down.
 - The steering column is unlocked.
3. Manually set the steering wheel to the desired position.
4. Release the pedal when the steering wheel has reached the desired position.
 - The steering column is locked.



Fig. 30

4.6 Switch parking or driving light on and off

Switch parking light on

Turn the headlight switch at the steering column to position "1".

Switch driving light on

Turn the headlight switch at the steering column to position "2".

Switch lights off

Turn the headlight switch at the steering column to position "0".



Fig. 31

4.7 Actuate indicators, full headlights, headlight flasher, horn

Switch indicators on

Push the multi-function switch as far as it will go forward (A) to actuate the left-hand indicator, or backwards (B) to actuate the right-hand indicator.

→ The control message "Indicator system" (Fig. 33) in the terminal flashes.

Switch full headlights on and off

1. Switch the driving light on.
2. Push the multi-function switch down (C) to switch on full headlights.

→ The control message "Full headlights" (Fig. 34) in the terminal lights up.

3. Pull the multi-function switch back to its initial position to switch the full headlights off again.

→ The control message "Full headlights" (Fig. 34) in the terminal goes out.

Actuate headlight flasher

Pull the multi-function switch up (C).

Sound the horn

Push the button of the multi-function switch (D).

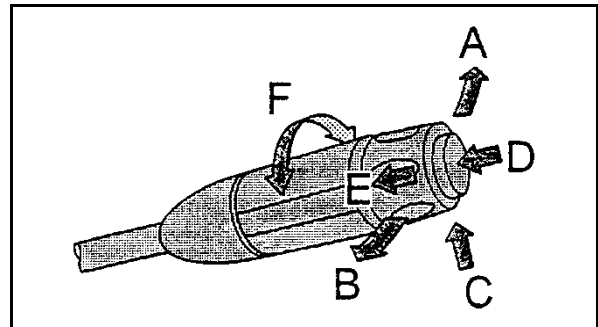

Fig. 32



Fig. 33



Fig. 34

4.8 Switch work lights on / off

Switch work lights on

1. Turn the light switch at the steering column to position "1" (parking light) or "2" (driving light).
2. Press the "Work lights" switch (Fig. 36/1) to position "On".

Switch work lights off

1. Press the "Work lights" toggle switch (Fig. 36/1) to position "Off".
2. Turn the headlight switch at the steering column to position "0" (off) if applicable.



Fig. 35

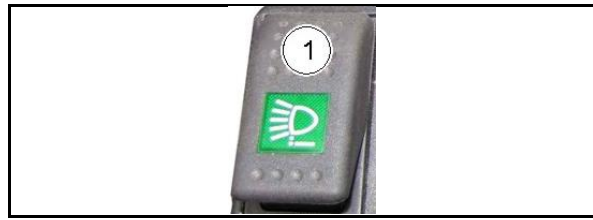

Fig. 36

4.9 Switch interior light on/off

Switch interior light on

Press the rocker switch (1) down at the front.

→ The interior light (2) lights up.

Switch interior light off

Press the rocker switch down at the rear.

→ The interior light (2) goes out.

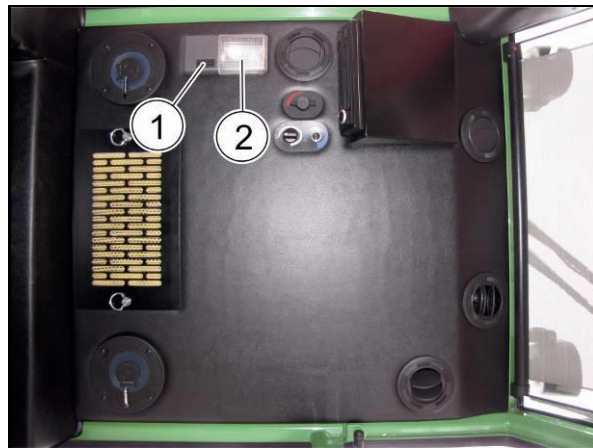

Fig. 37

4.10 Unroll/Roll up sun blind

Unroll sun blind

Pull the sun blind (1) down to the desired position.

Roll up sun blind

1. Use one hand to keep hold of the sun blind (1).
2. Use the other hand to press the red adjusting knob (2).

→ The sun blind rolls up.

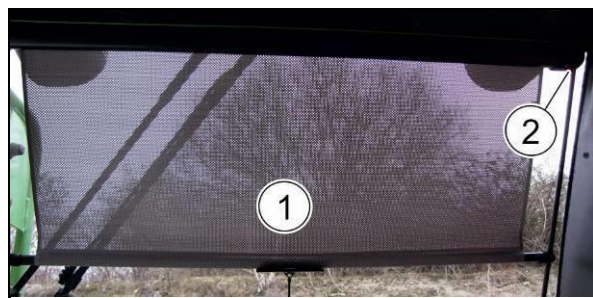

Fig. 38

4.11 Switch windscreen wiper on/off

Interval wiping

Turn the rotary switch forward in the direction of the arrow (F) to position "J".

Slow wiping

Turn the rotary switch backwards in the direction of the arrow (F) to position "I".

Quick wiping

Turn the rotary switch backwards in the direction of the arrow (F) to position "II".

Wiping and washing

Press the outer ring of the rotary switch in the direction of the arrow (E).

Switch windscreen wiper off

Turn the rotary switch forward in the direction of the arrow (F) to position "0".

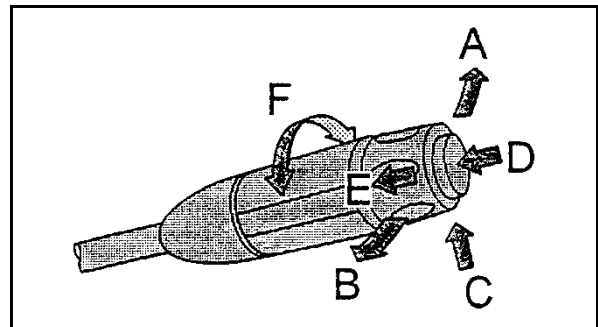

Fig. 39

4.12 Adjust outside mirror

1. Manually adjust the rear-view mirrors (1) such that you have a clear and complete view of the hazardous area at the rear and to the right and left of the machine.
2. Manually adjust the close-proximity mirror (2) such that you have a clear view of the bottom area beside the right-hand front wheel.
3. Manually adjust the wide-angle mirror (3) such that you have a clear and complete view of the hazardous area at the rear and to the right of the machine.



The right-hand mirror arm may be of hydraulically swivelling design by means of a key button in the control console (optional extra).

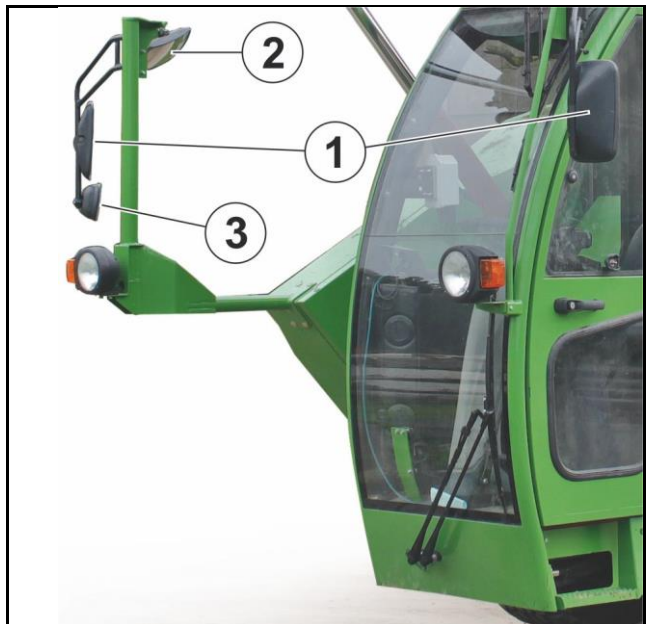

Fig. 40

4.13 Ventilate / Heat driver's cabin

Ventilate / Heat cabin compartment

1. Turn the fan regulator as required (1) to
 - level 1 = low,
 - level 2 = moderate,
 - level 3 = strong.
2. Open the slots of the ventilation nozzles (2) installed in the cabin ceiling and in the footwell.
3. Use the heating controller (3) to set the desired heating temperature.

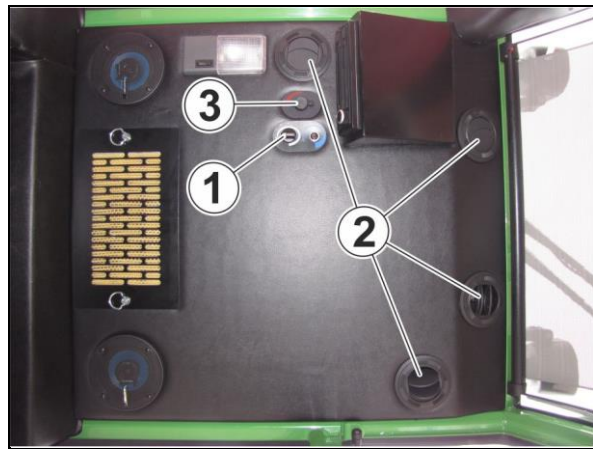



Fig. 41

4.14 Remove / Fix radio remote control

Optional extra

The values of the added ingredients can be read from the radio remote control display even outside the cabin.



Angle the radio remote control before its removal and insertion into the holder, in order to prevent the contacts from being damaged.

Remove radio remote control

1. Bend the bottom end of the radio remote control (1) in direction "B".
 2. Now move the radio remote control up.
- The radio remote control is now detached from the holder.

Fix radio remote control

1. Bend the bottom end of the radio remote control (1) in direction "B".
 2. Now move the radio remote control down into the guide rail of the holder.
 3. The radio remote control can be bent in direction "A" as soon as it has engaged.
- The radio remote control has been fixed.



Fig. 42

4.15 Extend / Retract counter-cutters

Mechanical counter-cutters:

1. Remove the locking bolt (2).
2. Extend or retract the counter-cutter (1) into or out of the mixing container and secure it in the desired position by means of the locking bolt.
3. Use the clip connector to secure the locking bolt against slipping out.



Fig. 43

Hydraulic counter-cutters (optional extra):

1. Extend or retract the counter-cutters (1) into or out of the mixing container by means of the key button in the control console.

	<p>Always extend or retract the hydraulic counter-cutters completely!</p> <p>It may take varying lengths of time until all counter-cutters have been completely extended or retracted.</p>
---	--

2. In order to change the position for the limit stop when extending:
 - 2.1 Retract the counter-cutters (1) completely out of the mixing container by means of the key button in the control console.
 - 2.2 Remove the screw (2) and screw it together with the thrust washers (3) in the desired position for the limit stop.

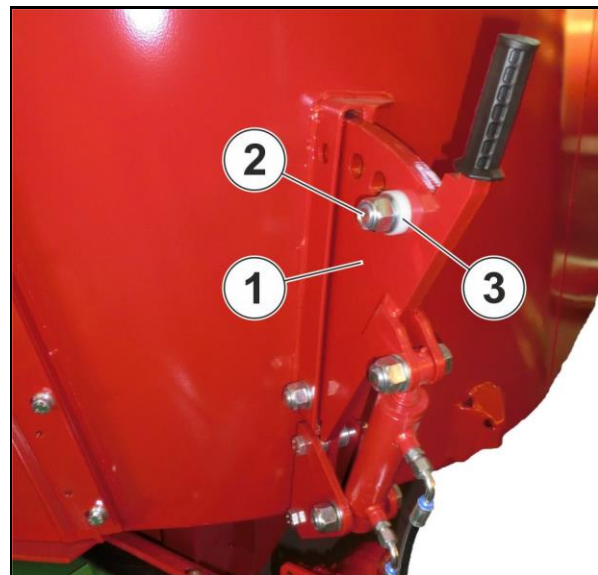

Fig. 44

4.16 Set deflector plate

WARNING



Risk of injury due to movements of the machine or its working tools!

Secure the machine against accidental starting, rolling and actuation!

1. Lower the dosage gate(s) completely.
2. Unscrew the nut (4).
3. Move the adjusting sheet (3)
 - up (1): the deflector plate (5) swivels out to its maximum extent when the dosage gate is lifted.
 - down (2): the deflector plate (5) swivels out to its minimum extent when the dosage gate is lifted.
4. Retighten the nut (4).

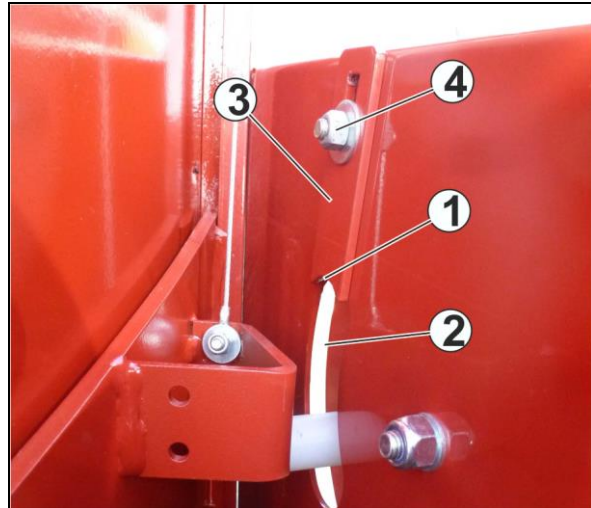

Fig. 45

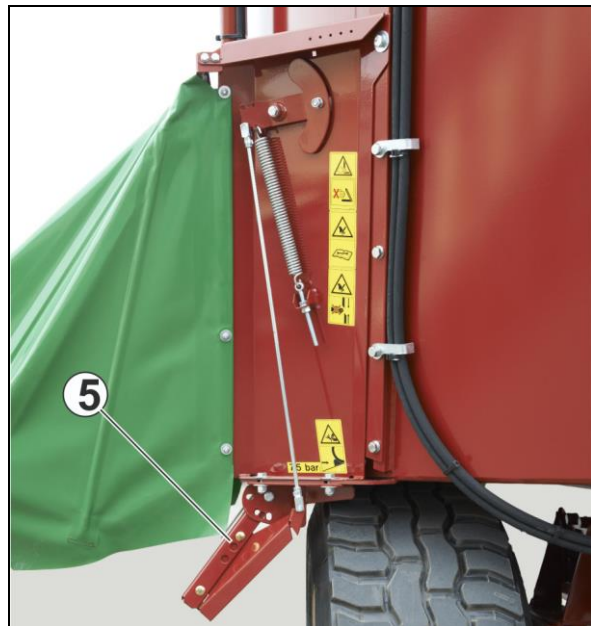

Fig. 46

4.17 Preheating devices

Optional extra

DANGER



Danger to life due to electric shock when touching the machine if a preheating device is improperly connected to the power supply!

Make sure that the protective conductor ("ground") is connected to a residual current circuit breaker (RCCB) with max. 30 mA through all used components such as extension cables, timers, sockets, fixed cables.





Avoid damage to the machine and electrical equipment:

- Exclusively use the included connecting cable to connect the preheating devices to the power supply (230 V A.C.)!
- Completely unwind the extension cables from the cable reel to avoid overheating and scorching!
- Do not use multiple socket power strips to connect several preheating devices!
- Make sure to adapt cable cross sections, timers, sockets, power backups etc. to the connected output (see table)!
- Limit the preheating time such that overheating of the warmed-up operating media and damage to the preheating devices are excluded!
- Have malfunctions on the preheating devices eliminated by qualified staff only!



Always adapt the preheating time to the ambient temperatures! Usually it is enough to start preheating shortly before work begins.

Observe the fact that the temperature is measured near the heating element during preheating of hydraulic oil. The preheating device may therefore switch off before the entire tank contents have been warmed up or before the preset time has been reached when using a timer.

Preheating devices		Output	Input current	Mains voltage
	Diesel engine preheating	750 W	3.4 A	230 V A.C.
	Hydraulic oil preheating	1000 W	4.5 A	230 V A.C.

Connection of a preheating device to the machine (at the left-hand front beneath the driver's cabin)

- (1) Protective conductor

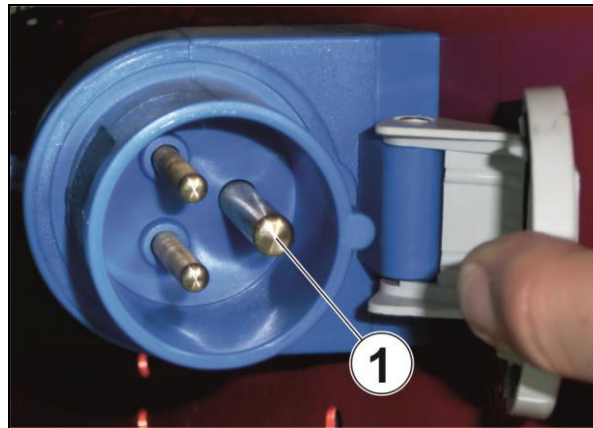

Fig. 47

Coupling of included connecting cable

- (1) Protective conductor



Fig. 48

Plug of included connecting cable

- (1) Protective conductor



Fig. 49

5 Operation

5.1 Switches / Key buttons of control console

Warning lamp

- Hydraulic oil overheating**
 Lights up when the hydraulic oil temperature exceeds 90°C.
 Turn the diesel engine off and remedy the cause of the malfunction!
- Milling drum/Conveyor drum stop**
 Lights up when the milling drum/conveyor drum is disabled due to overload.
 Reverse the milling drum/conveyor drum!



Fig. 50

Differential lock

- off
- on



Fig. 51

Side window wiper

- off
- on (wiping)
- on (wiping and washing)



Fig. 52

Right-hand mirror arm

- retract
- off
- extend

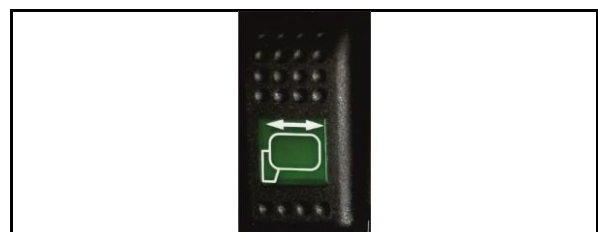

Fig. 53

Parking brake

- off
- on



Fig. 54

Warning lights

- off
- on



Fig. 55

Travelling mode

- Travelling mode I = 0-10 km/h
- Travelling mode II = 0-25 km/h



Fig. 56

Work lights

- off
- on (partly)
- on (all)



Fig. 57

Dosage gate

- lift
- off
- lower



Fig. 58

Hydraulic counter-cutters

- extend (in)
- off
- retract (out)

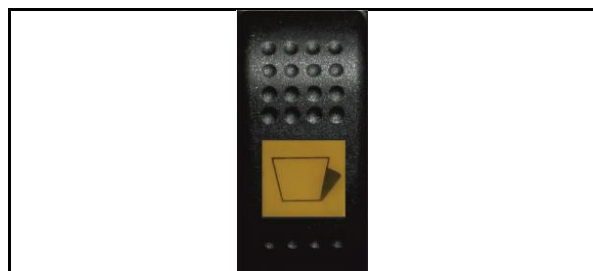

Fig. 59

Mixing auger(s)

- off
- level I = 15 min⁻¹
- level II = 40 min⁻¹



Fig. 60

Side discharge conveyor

- retract (out)
- off
- extend (in)

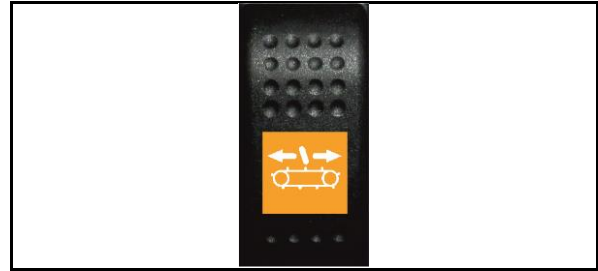

Fig. 61

Side discharge conveyor left / right

- off
- on

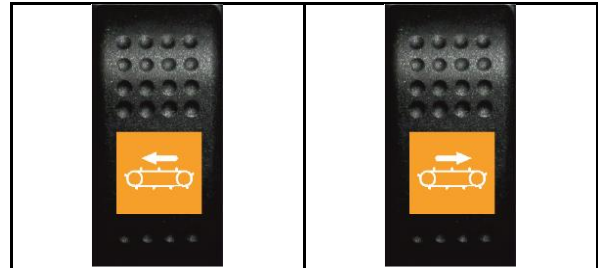

Fig. 62

Fig. 63

Machine with milling drum

Elevator conveyor speed

- max = maximum speed
- red = reduced speed (can be set by means of the control dial "Elevator conveyor speed")

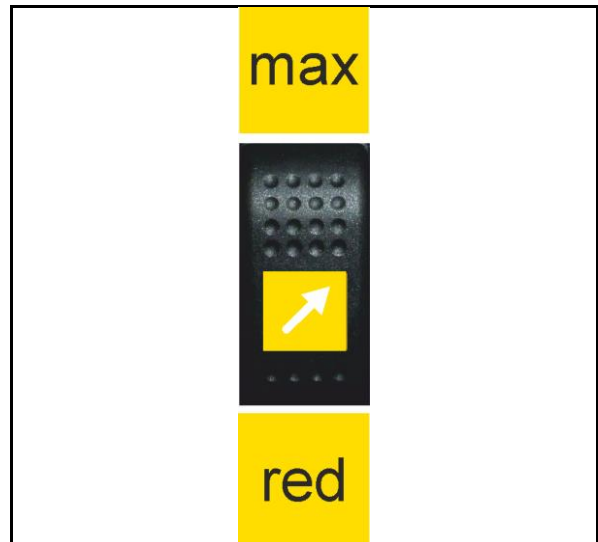

Fig. 64

Control dial, elevator conveyor speed

- 1 = lowest speed
- 10 = highest speed

After pressing the "Elevator conveyor speed" switch to position "red", the elevator conveyor runs at the set speed when the joystick is moved to the left.



Fig. 65

Machine with Fast-Cut cutting unit (optional extra)

Fast-cut cutting knives

- disable
- enable



Fig. 66

5.2 Joystick

- (1) Enabling button
 - keep pressed = "Charging" mode is activated: Milling drum/Conveyor drum and elevator conveyor start to run if joystick is moved to the left (5) or right (6)
- (2) Rocker switch, milling drum protection/cutting unit
 - keep pressed to the right = Lift milling drum protection/cutting unit
 - keep pressed to the left = Lower milling drum protection/cutting unit
- (3) Move joystick backwards = Lift pick-up arm
- (4) Move joystick forward = Lower pick-up arm
- (5) Move joystick to the left (with enabling button (1) pressed) = Power milling drum/conveyor drum and elevator conveyor in conveying direction
- (6) Move joystick to the right (with enabling button (1) pressed) = Reverse milling drum/conveyor drum and elevator conveyor (reverse running direction)

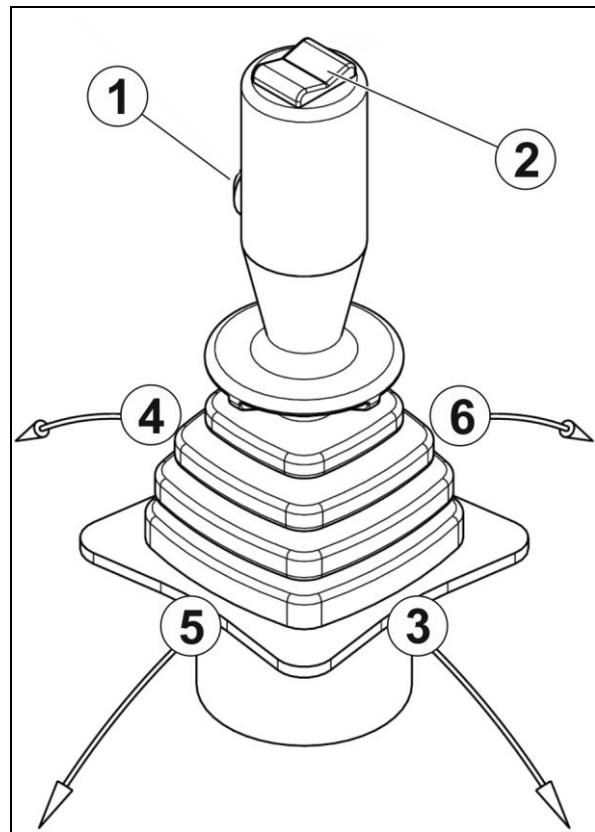

Fig. 67

5.3 Terminal

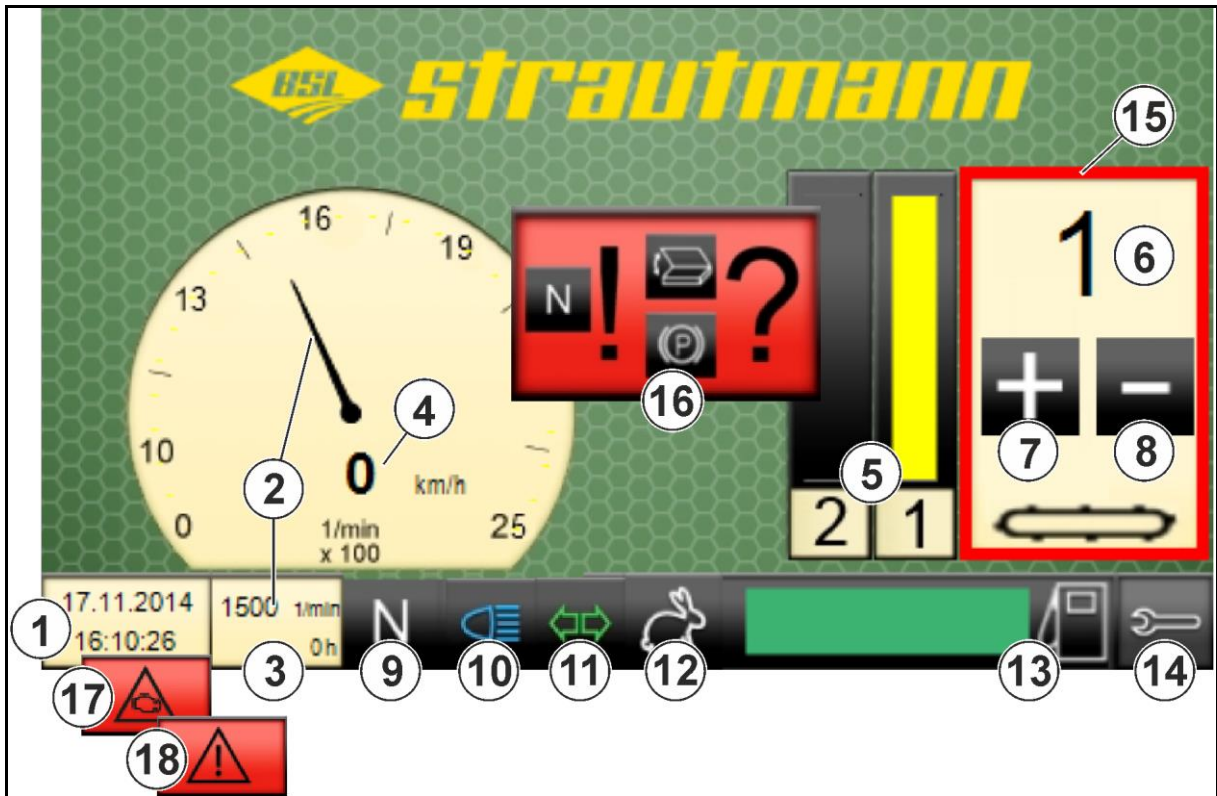



Fig. 68

No.	Function as	
	Read-out	Display key
(1)	Date / Time	
(2)	Diesel engine speed	
(3)	Service hours	
(4)	Travelling speed	
(5)	Opening width of dosage gate(s): • yellow bar = dosage gate lifted (in proportion to bar height)	
(6)	Speed level of side discharge conveyor *	
(7)		Increase speed of side discharge conveyor *
(8)		Reduce speed of side discharge conveyor *
(9)	Direction of motion: • N = neutral; no direction of motion selected • Arrow pointing upwards = Direction of motion forward • Arrow pointing downwards = Direction of motion backwards (switching-over to rear-view camera picture if necessary)	

No.	Function as	
	Read-out	Display key
(10)	Full headlights: • Symbol lights up blue = Full headlights on	
(11)	Indicator: • Symbol flashes green = Indicator on • Symbol flashes red = Indicator defective	
(12)	Operating mode: • "Rabbit" symbol = "Travel" mode • "Snail" symbol = "Charge" mode (enabling button on the joystick is pressed)	
(13)	Amount of fuel in fuel tank: • green bar = enough fuel available • red bar = little fuel available; top up fuel!	
(14)		Open "Parameter/Diagnosis" menu
(15)	Note: Dosage gate lifted; switch on side discharge conveyor before switching on the mixing auger(s)!	
(16)	Note: Before actuating the accelerator pedal, select direction of motion and deactivate the parking brake!	
(17)	 Warning: Engine error! Immediately turn the diesel engine off and contact your dealer, the Strautmann customer service or an authorised workshop! Only restart the diesel engine when the error has been eliminated!	Open "Diagnosis" menu
(18)	 Warning: No brake function due to accumulator charging pressure being too low! Immediately stop the machine and contact your dealer, the Strautmann customer service or an authorised workshop! Only continue your travel when the error has been eliminated!	Open "Diagnosis" menu



* 2 side discharge conveyors always run at the same speed. A change in speed will always affect both side discharge conveyors.

5.3.1 "Parameter / Diagnosis" menu



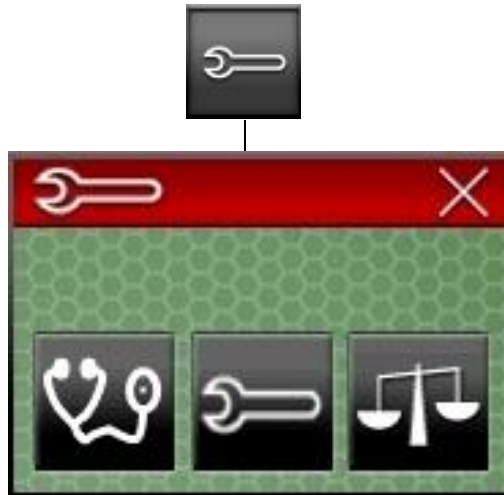

Use the  display key to open the "Parameter / Diagnosis" menu.

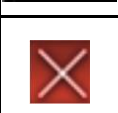

	"Diagnosis" menu Opens the "Diagnosis" menu (see chapter ""Diagnosis" menu", page 59).
	"Parameter" menu Opens the "Parameter" menu (see chapter ""Parameter" menu", page 64).
	"Weighing device" menu (No function. Please observe the included sub-supplier documentation of the weighing device if necessary!)
	Exit menu Closes the "Parameter / Diagnosis" menu.

5.3.2 "Diagnosis" menu

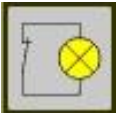
Possible readouts of diagnosis outputs:

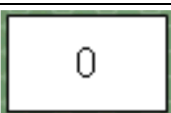
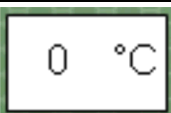
	Active status
	Inactive status
	Value
	Value and unit (example)

The following symbols indicate which signal type is called up:

	<p>Switching output</p> <p>Examples: Light, relay, valve</p>
	<p>Switching input</p> <p>Examples: Switch, sensor</p>
	<p>Analog input</p> <p>Examples: Foot throttle, pressure sensor, sensor</p>
	<p>Frequency</p> <p>Examples: Diesel engine speed</p>

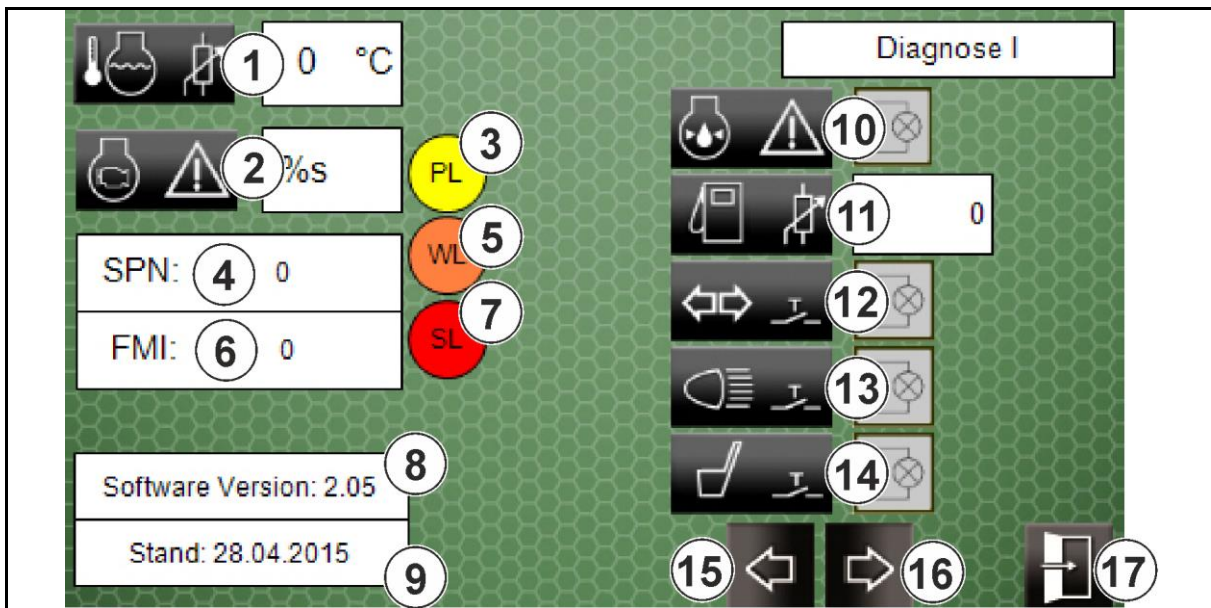

Fig. 69

- (1) Engine coolant temperature *
- (2) Current engine errors (number) *
- (3) Protect Lamp: Minor error; engine is running
- (4) Suspect parameter number *
- (5) Warning Lamp: Medium-severity error; engine is running
- (6) Failure mode identifier *
- (7) Stop Lamp: Serious error; engine stopped
- (8) Number of software version
- (9) Date of software version
- (10) Accumulator charging pressure (brake pressure)

- (11) Sensor value of filling level sensor in fuel tank
- (12) Indicator signal
- (13) Full headlights
- (14) Seat contact switch
- (15) Scroll back **
- (16) Scroll forward **
- (17) Exit menu **

* With errors indicated by a red frame.

** Display key

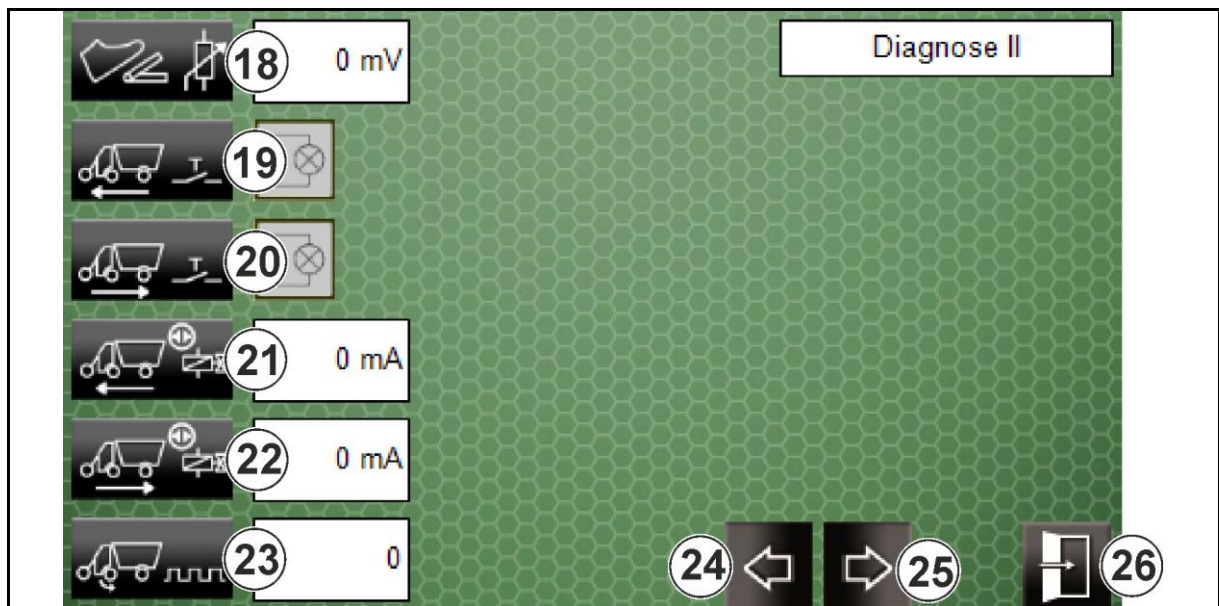

Fig. 70

- (18) Sensor value of accelerator pedal
- (19) Reversing gear, direction of motion forward
- (20) Reversing gear, direction of motion backwards
- (21) Hydraulic pump of traction drive, direction of motion forward
- (22) Hydraulic pump of traction drive, direction of motion backwards
- (23) rpm sensor of traction drive
- (24) Scroll back *
- (25) Scroll forward *
- (26) Exit menu *

* Display key

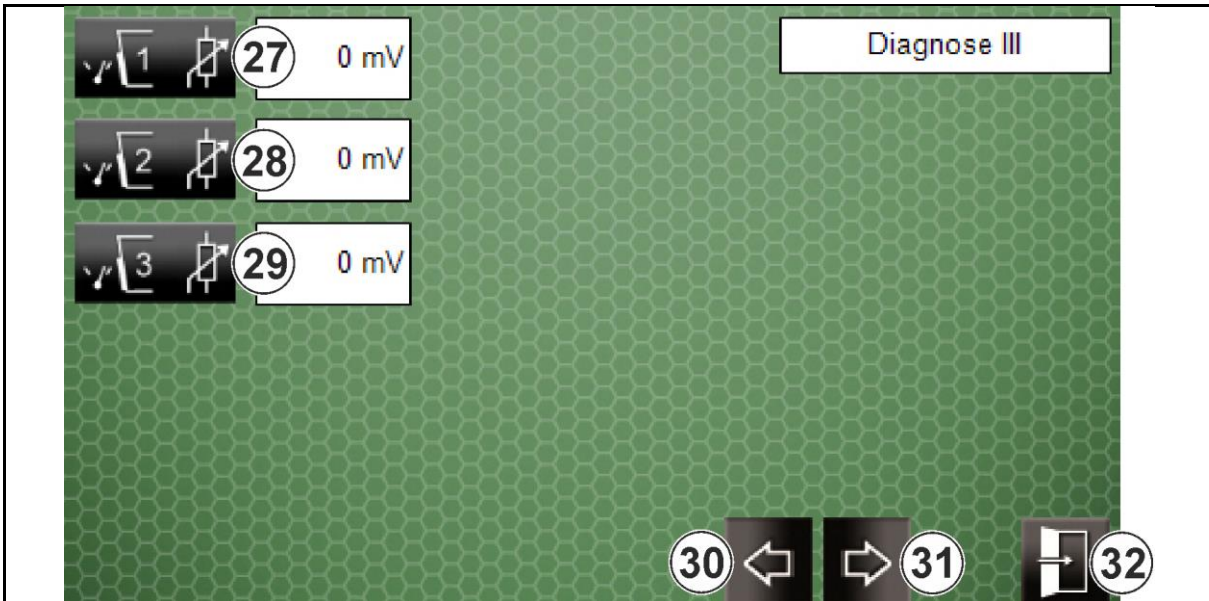

Fig. 71

- (27) Sensor value of dosage gate 1
- (28) Sensor value of dosage gate 2
- (29) Sensor value of dosage gate 3
- (30) Scroll back *
- (31) Scroll forward *
- (32) Exit menu *

* Display key

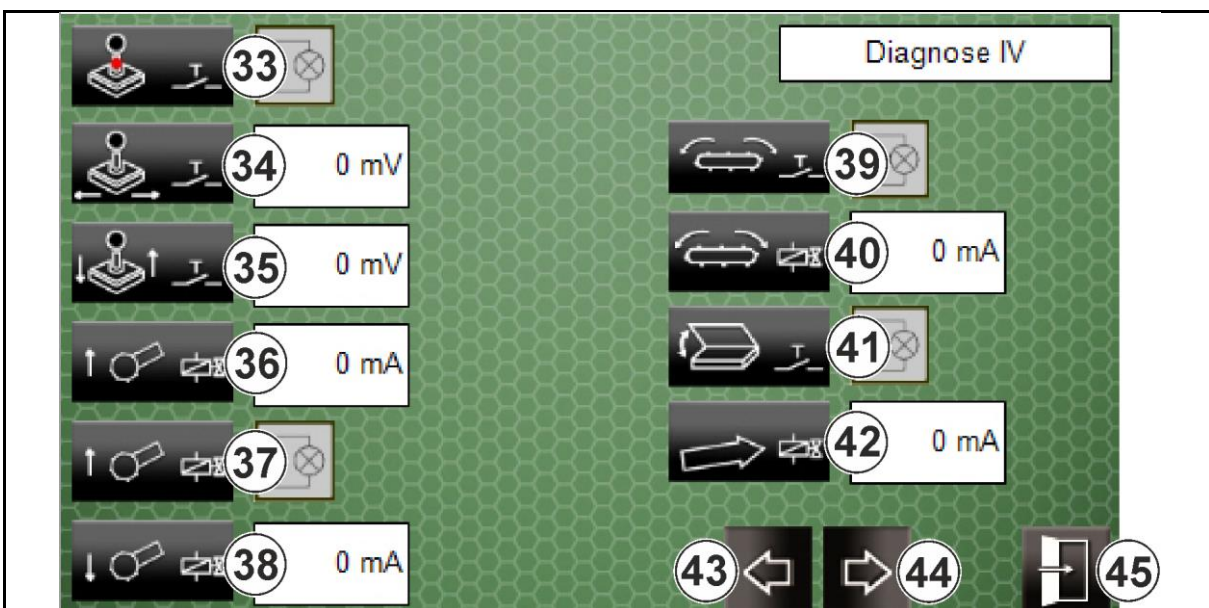

Fig. 72

- (33) Enabling button on joystick
- (34) Sensor value of joystick transverse axis (power/reverse milling drum/conveyor drum and elevator conveyor in the conveying direction)

- (35) Sensor value of joystick longitudinal axis (lift/lower pick-up arm)
- (36) Valve current "Lift pick-up arm"
- (37) Direction signal of pick-up arm
- (38) Valve current "Lower pick-up arm"
- (39) Side discharge conveyor speed
- (40) Valve current of side discharge conveyor
- (41) No function
- (42) Valve current of elevator conveyor
- (43) Scroll back *
- (44) Scroll forward *
- (45) Exit menu *

* Display key

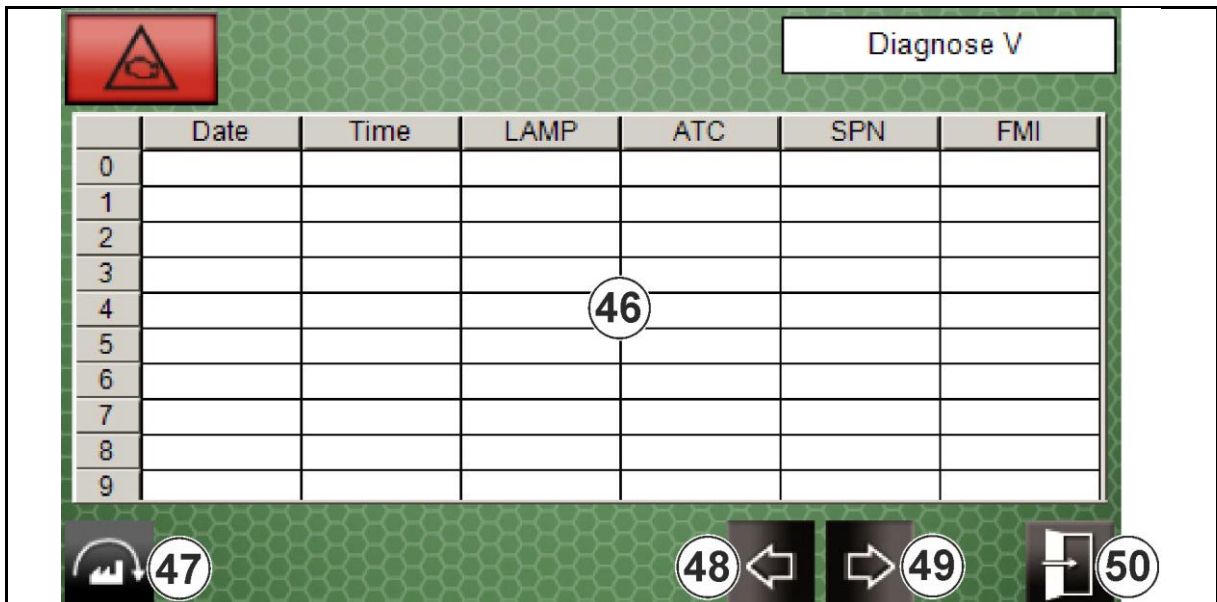

Fig. 73

- (46) Error table indicating the latest 10 engine errors:

Date = Date of error

Time = Time of error

LAMP = Active error lamps

SPN = Suspect parameter number

FMI = Failure mode identifier

- (47) Delete error table
- (48) Scroll back *
- (49) Scroll forward *
- (50) Exit menu *

* Display key

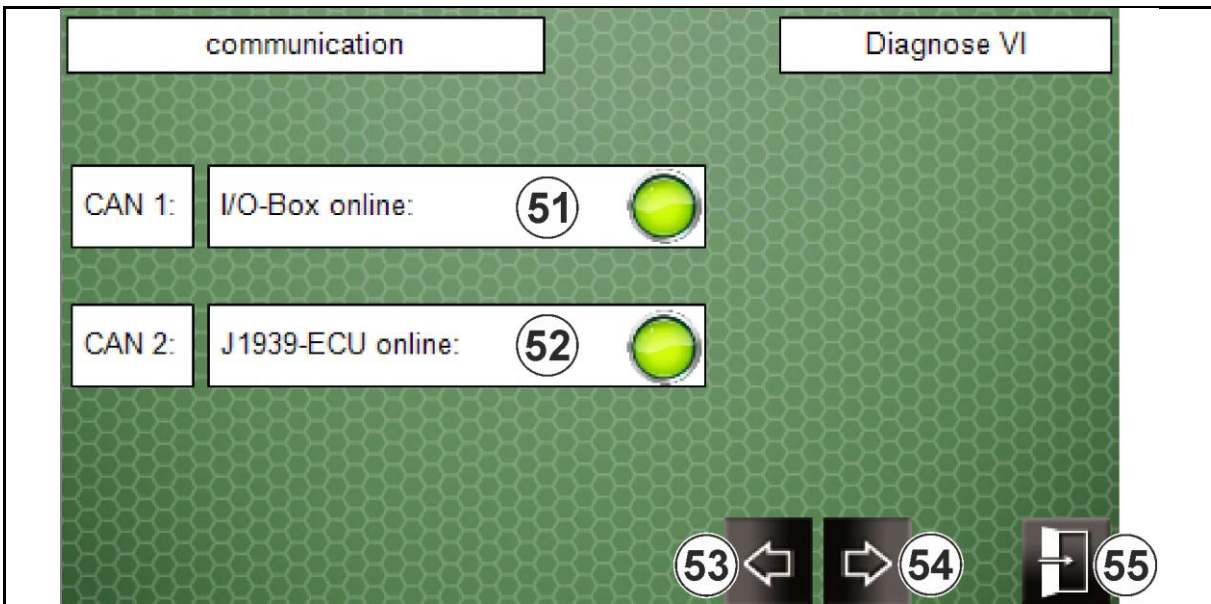

Fig. 74

- (51) Input/Output box (ICN-V) online with green display
- (52) ECU for communication with engine control unit online with green display
- (53) Scroll back *
- (54) Scroll forward *
- (55) Exit menu *

* Display key

5.3.3 "Parameter" menu

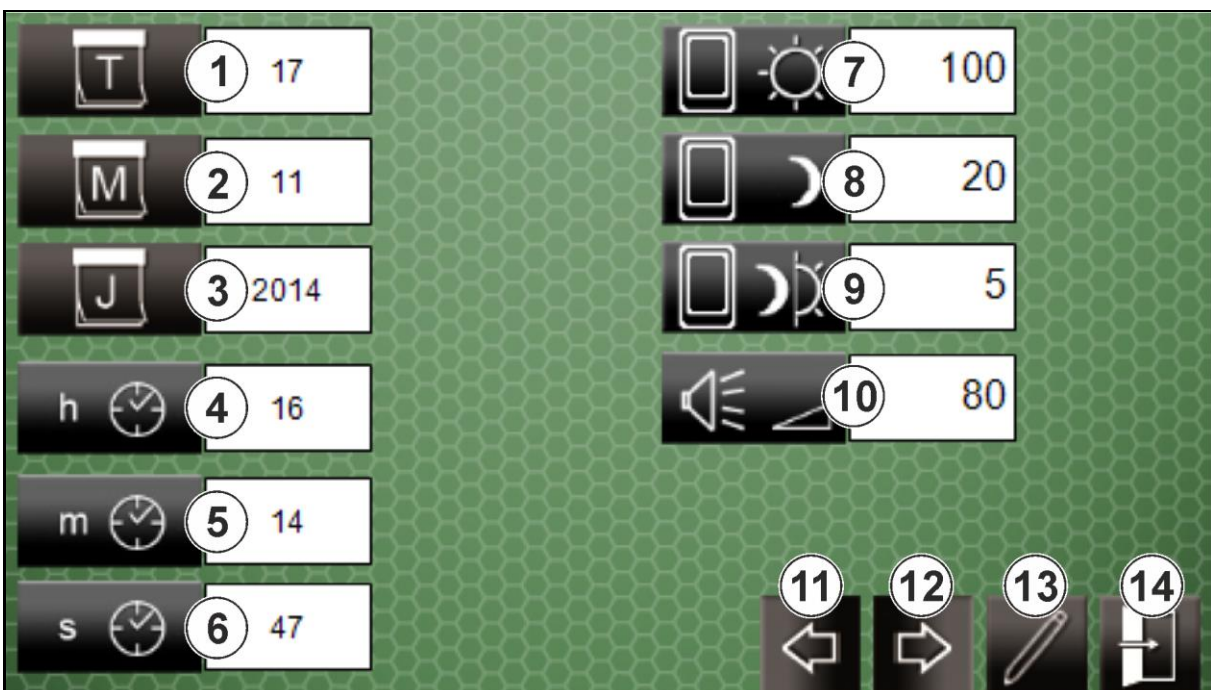

Fig. 75

- (1) Date: Day *
- (2) Date: Month *
- (3) Date: Year *
- (4) Time: Hour *
- (5) Time: Minute *
- (6) Time: Second *
- (7) Display brightness in daylight (factory setting: 100 %) *
- (8) Display brightness in darkness (factory setting: 20 %) *
- (9) Switching-over of display brightness (factory setting: 5 %; the higher the value, the later the display switches over from "Darkness" to "Daylight" mode) *
- (10) Display sound volume (factory setting: 80 %) *
- (11) Scroll back *
- (12) Scroll forward *
- (13) Enter access code for change of basic terminal settings (only for customer service staff) *
- (14) Exit menu *

* Display key

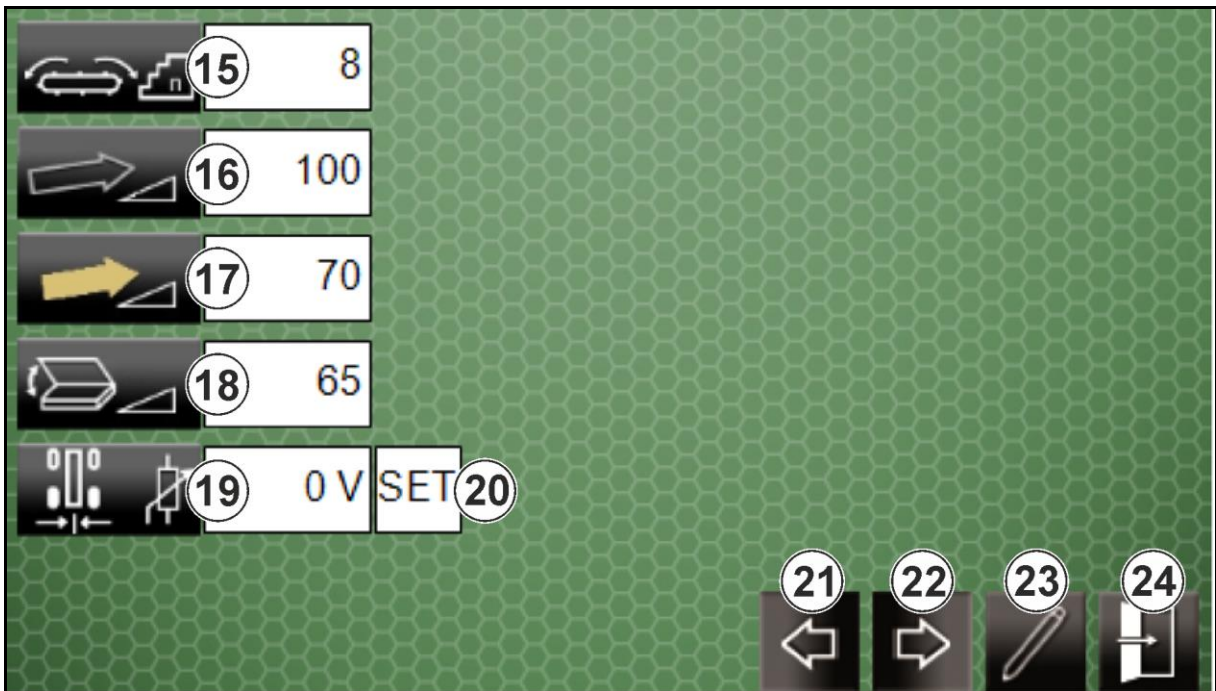

Fig. 76

- (15) Speed levels of side discharge conveyor (factory setting: 8) *
- (16) Full elevator conveyor speed (factory setting: 100 %) *
- (17) Half the elevator conveyor speed (factory setting: 70 %) *
- (18) No function
- (19) No function
- (20) No function
- (21) Scroll back *

- (22) Scroll forward *
- (23) Enter access code for change of basic terminal settings (only for customer service staff) *
- (24) Exit menu *

* Display key

5.4 Manual throttle lever

- (1) Neutral
- (2) Maximum speed

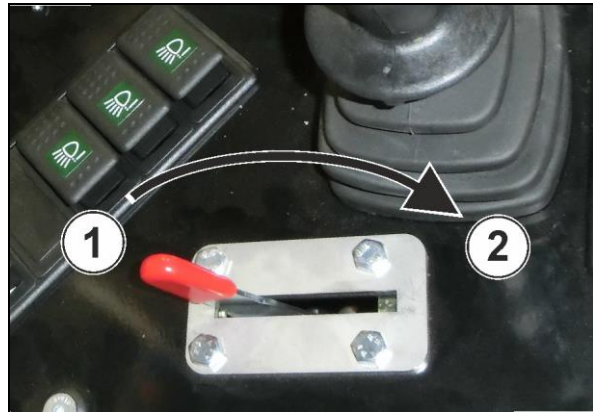

Fig. 77

6 Travelling mode



It is imperative to observe the included diesel engine operating instructions.

6.1 Road traffic regulations



Observe the national road traffic regulations when travelling on public roads.

Owner (user) and driver (operator) of the vehicle are responsible for observing the national road traffic regulations.

6.2 Start diesel engine



Tow-starting of the diesel engine is not possible, as the machine is equipped with a hydrostatic traction drive.

DANGER



Risk of poisoning or even death due to exhaust gases when starting or operating the diesel engine in non-ventilated or closed locations!

- Connect the exhaust to a required ventilation system before starting or operating the diesel engine in a closed location.
- Ensure sufficient ventilation.

WARNING



Risk due to accidental rolling of the machine during start of diesel engine!

Only start the diesel engine from the driver seat.

1. Use the battery main switch to switch the power supply on.
2. Switch the parking brake on.
3. Put the ignition key into the ignition lock.
4. Set the manual throttle lever to idle position.
5. Turn the ignition key to position I and wait for the terminal to finish booting.
This will take approx. 4 seconds, after a longer downtime of the machine up to 3 minutes.
The terminal must have finished booting **before** the diesel engine starts to ensure proper operation of terminal and machine.
6. Turn the ignition key to position II.
7. Turn the ignition key to position III and keep hold of it against the spring pressure, until the diesel engine starts (max. 30 seconds to avoid overheating of the starter).
Release the ignition key as soon as the diesel engine starts.



When releasing the ignition key before the diesel engine starts, wait for the starter to come to a standstill before the next start attempt, in order to prevent the starter from being damaged.

If the diesel engine does not start, wait for at least 2 minutes before carrying out another start attempt such that the starter can cool down.

8. Let the cold diesel engine warm up in idle position for 3-5 minutes (in case of frost at 1000-1200 min⁻¹).

6.3 Winter operation of diesel engine



- Keep the batteries in a good state of charge.
- Ensure that the viscosity class of the engine oil complies with the outside temperatures.
- Use winter diesel fuel at outside temperatures below 0°C.
- Do not use an engine starter spray for starting the diesel engine.
- Top up anti-freezing agent early enough.
- Observe also the included operating instructions for the diesel engine.

6.4 Travelling and braking



Only change the direction of motion with the machine being stationary!

Use the diesel engine brake at minimum engine speed when travelling downhill (only on roads with a good grip!), thus saving the service brake.



Travelling with differential lock

Only use the differential lock to start travelling on smooth or soft ground!

Only switch the differential lock on with the machine being stationary!

Carefully start travelling if the differential lock has not completely engaged!

Avoid cornering!

Do not exceed a travelling speed of 5 km/h!

WARNING



Risk to people / animals during travelling mode!

- Check the hazardous area of the machine. Only if there are no people / animals present in the hazardous area of the machine is the machine allowed to be moved.
- Ensure that there are no people or objects on the platform.
- If you have to leave your machine with the diesel engine running, secure the machine against accidental rolling by means of the parking brake.

1. Start the diesel engine.
2. Switch the parking brake off.
3. Lift the lever (4) of the reversing gear and switch it
 - to the front position to preselect the direction of motion "Forward",
 - to the rear position to preselect the direction of motion "Backwards".
4. Switch travelling mode II on if necessary.
5. Take hold of the steering wheel (2) with both hands.

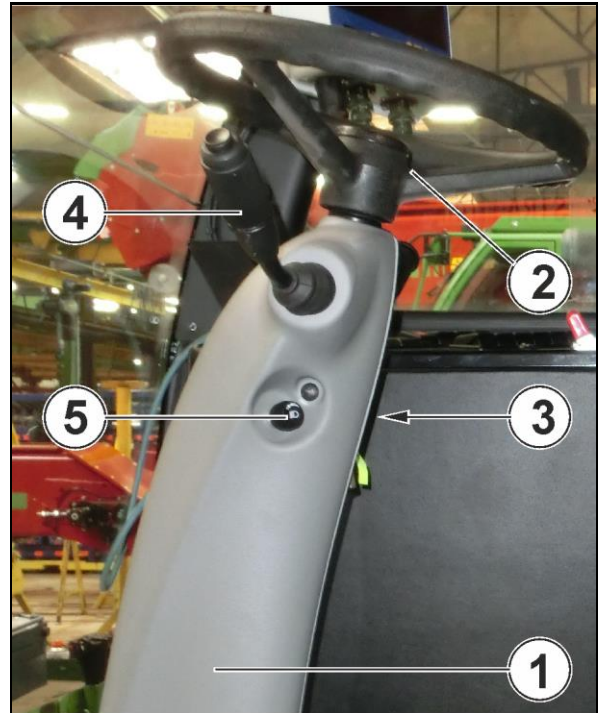

Fig. 78

6. Use the right leg to press the accelerator pedal (9).
 - The machine moves in the preselected direction of motion.
7. To slow down the machine:

Take your foot off the accelerator pedal and press the right-hand brake pedal (8) with your right leg or the left-hand brake pedal (7) with your left leg.

 - The machine slows down.

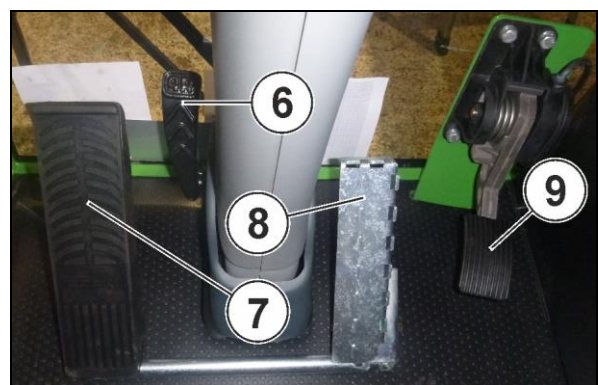

Fig. 79

6.5 Turn off diesel engine

1. Switch the parking brake on.
2. Set the manual throttle lever to idle position.

Let the diesel engine run in idle position for 5 minutes, in order to allow hot diesel engine components to cool down and prevent a heat build-up in the engine compartment.

3. Turn the ignition key to position 0.
→ The diesel engine stops and the ignition is off. The terminal goes out.
4. Pull the ignition key out when leaving the driver's cabin.
5. Top the fuel tank up, in order to minimise problems due to condensate.
If the fuel tank is topped up after operation of the machine, the humid air is pushed out of the tank.
6. Use the battery main switch to switch the power supply off.

7 Use of machine

7.1 Fill fodder mixing wagon

7.1.1 Recommended filling order

1. Pick-up highly-structured fodder components (hay, straw etc.) (with the mixing auger/s switched on).
Have them possibly mixed for some time before filling in the next component.
2. Pick up concentrated feed, grain feed etc.
3. Fill in mineral feed.
4. Pick up grass silage.
5. Pick up maize silage, grain silage.
6. Pick up fodder components with a high proportion of water, e.g. draff, potato pulp or beet chips.
7. Pick up liquid components, e.g. liquid yeast, molasses.

7.1.2 Pick up silage from the bunker silo



- Do not let the milling drum/the Fast-Cut cutting knives come into contact with stationary elements such as e.g. silo walls or the floor.
- Ensure that no foreign objects such as e.g. stones lying on the floor, metal objects or parts of the silo cover (tyres) get into the milling drum/between the Fast-Cut cutting knives.
- Apply load to the milling drum/cutting unit as equally as possible over the entire width.
- Observe the maximum load of the machine and the filling order of the individual fodder components to prevent a build-up of overload (e.g. at the counter-cutters). Overload may damage the power train and bend the cutting knives of the mixing auger.

Machine with milling drum

WARNING

Risk of injuries due to the rotating pick-up milling cutter, the opening and closing milling drum protection, the lifting and lowering cutter arm, the advancing and reversing machine!

Make sure that people and animals leave the hazardous area of the machine.

1. Open the milling drum protection (Fig. 80/3).
2. For the first cut, position the milling drum at the silo stack, such that the top edge (Fig. 81/1) of the silo stack is within the range (Fig. 81/2) between the centre (Fig. 81/3) of the milling drum and the milling hood (Fig. 81/4).

This prevents silage from being conveyed onto the silo stack during first cut.

3. Switch the mixing auger on (level I) if necessary (Fig. 82).
4. Set the manual throttle lever to maximum speed.
5. Move and keep hold of the joystick to the left (Fig. 80/6) with the enabling button pressed (Fig. 80/1):
 - Milling drum and elevator conveyor start to run in the conveying direction.
6. Move close to the silo stack, such that the scraper bar (Fig. 81/5) tightly fits to the silo stack.

This allows the silage to be conveyed into the conveyor duct of the elevator conveyor without substantial losses.

7. Release the enabling button (Fig. 80/1), keep hold of the joystick to the left (Fig. 80/6) and move it forward (Fig. 80/5):
 - The pick-up arm lowers, while the silage is cut out of the silo stack and conveyed into the mixing container.
8. Reduce the drive speed of the elevator conveyor by means of the switch and the "Elevator conveyor speed" control dial (Fig. 83) if necessary, e.g. if silage is thrown over the mixing container.
9. Observe also the weighing device display during picking-up.

10. Reverse milling drum and elevator conveyor if necessary, e.g. if
 - the milling drum is clogged due to overload and the warning lamp "Milling drum/Conveyor drum stop" lights up.
 - too much silage has been picked up which should not be conveyed into the mixing container.

To reverse, move the joystick to the right (Fig. 80/7) and keep hold of it with the

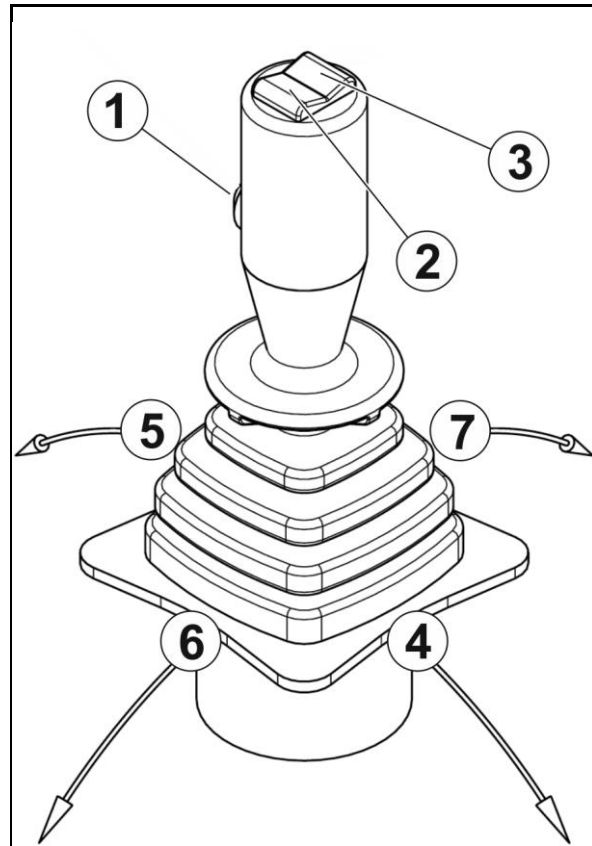

Fig. 80

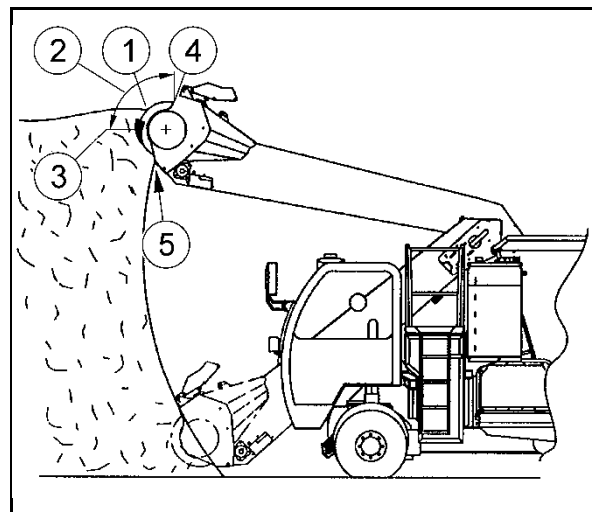

Fig. 81



Fig. 82

enabling button pressed (Fig. 80/1).

→ Elevator conveyor and milling drum run in reverse direction. The silage is thrown out to the front.

11. Finish picking-up:

11.1 Release the joystick such that it returns to its neutral position.

→ Milling drum and elevator conveyor stop.

11.2 Close the milling drum protection (Fig. 80/3).

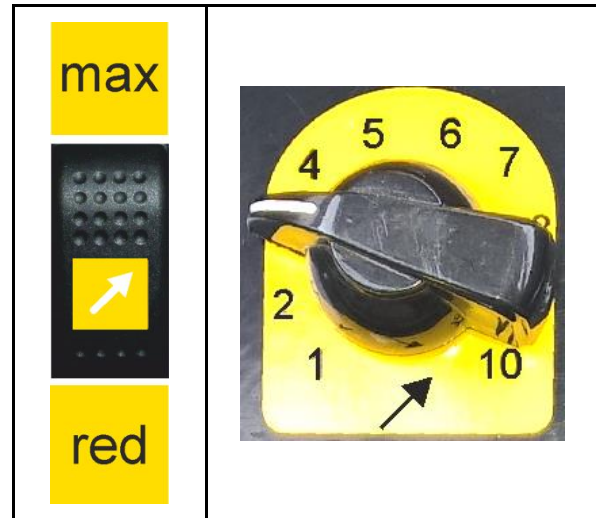

Fig. 83

Machine with Fast-Cut cutting unit (optional extra)

WARNING



Risk of injuries due to the working cutting knives, the lifting and lowering cutting unit, the rotating conveyor drum, the lifting and lowering pick-up arm, the machine travelling forwards and backwards!

Make sure that people and animals leave the hazardous area of the machine.

1. Lower the cutting unit completely (2).
2. Lift the pick-up arm (4) until the cutting knives have reached a position above the silo top edge.
3. Move close to the silo stack such that
 - a 10-15 cm wide strip of silage can be picked up when handling grass silage.
 - the scraper bar rests on the silo stack when handling maize silage.
4. Switch the mixing auger(s) on if necessary (level I) (Fig. 85).
5. Set the manual throttle lever to maximum speed.
6. Activate the cutting knives (Fig. 86).
7. Move and keep hold of the joystick to the left (6) with the enabling button (1) pressed:
 - The cutting knives work, conveyor drum and elevator conveyor start to run in the conveying direction.

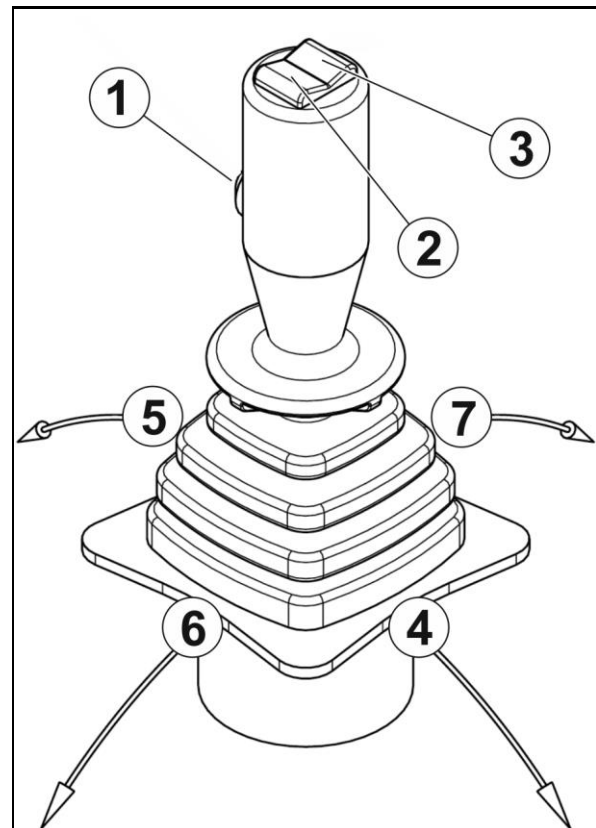

Fig. 84

8. Release the enabling button (1), keep hold of the joystick to the left (6) and move it forward (5):

→ The pick-up arm lowers, while the silage is cut out of the silo stack and conveyed into the mixing container.

9. Lower the drive speed of the elevator conveyor by means of the manual throttle lever if necessary (e.g. if silage is thrown over the mixing container).

10. Observe also the weighing device display during picking-up.

11. Reverse conveyor drum and elevator conveyor if necessary, e.g. if

- the conveyor drum is clogged due to overload and the warning lamp "Conveyor drum stop" (Fig. 87) lights up.
- too much silage has been picked up which should not be conveyed into the mixing container.

To reverse, move the joystick to the right (Fig. 84/7) and keep hold of it with the enabling button pressed (Fig. 84/1).

→ Elevator conveyor and conveyor drum run in the reverse direction. The silage is thrown out to the front.

12. Finish picking-up:

- 12.1 Release the joystick such that it returns to its neutral position.

→ Cutting knives, conveyor drum and elevator conveyor stop.

- 12.2 Deactivate the cutting knives (Fig. 86).

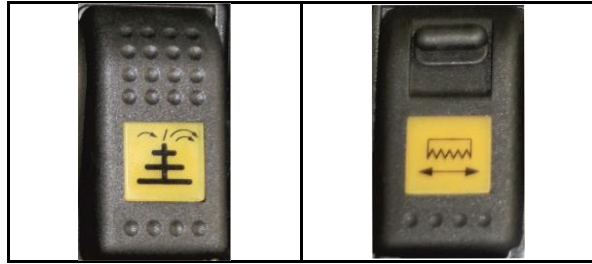

Fig. 85

Fig. 86



Fig. 87

7.1.3 Pick up bales, bulk materials and other items

Pick up bales



Remove strings, nets or foils before picking up bales.

Cuboid bales

Pick them up lengthwise

Move slowly forward during picking-up.

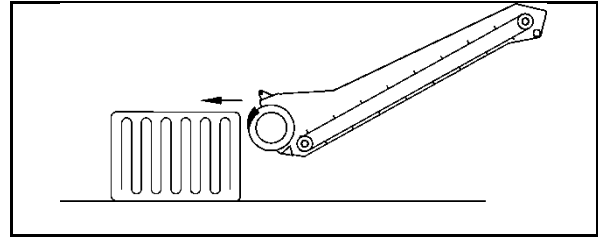

Fig. 88

Round bales

Pick them up from the front.

Pick them up from top to bottom.

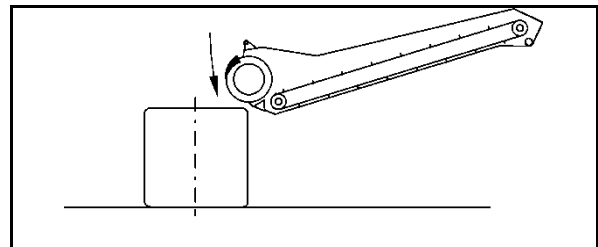

Fig. 89

Recommended engine speed

1500-1600 min⁻¹

Pick up bulk materials (ground grain, concentrated feed, draff etc.)

Move slowly forward with lowered pick-up arm.

With Fast-Cut cutting unit (optional extra):

Do not switch on the Fast-Cut cutting knives.

Lift the cutting unit half way.

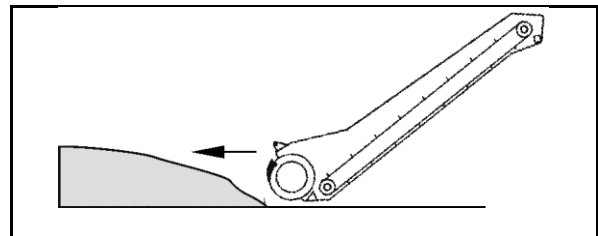

Fig. 90

Recommended engine speed

1000 min⁻¹

7.1.4 Fill in fodder additives through hydraulic feed hopper

Optional extra

WARNING



Risk of injury to hands and fingers due to being crushed, becoming entangled or being drawn in by the rotating dosing auger!

Never use the hydraulic feed hopper with the protective grating missing or being defective!

Never press fodder additives into the hydraulic feed hopper with your hands or an object!

1. Open the cover (1) of the hydraulic feed hopper (2) and secure it against slamming.
2. Fill the fodder additives into the hydraulic feed hopper.
3. Press the key button (3) down until the dosing auger has conveyed the fodder additives into the mixing container.
4. Close the cover of the hydraulic feed hopper.



Fig. 91

7.2 Mix fodder components



- Switch the mixing auger always to level I (15 min^{-1}) for mixing fodder.
- Stop the mixing process before extending or retracting the counter-cutters.
- Extend the counter-cutters into the mixing container only as far as to ensure that the fodder will not get entangled by or pile up on the counter-cutters.
- Stop the mixing process when the fodder components have been homogeneously mixed. In case of a too long mixing process, the mixture risks to lose its structure.
- Regularly sharpen the cutting knives of the mixing auger. Sharp cutting knives reduce the required mixing auger power.

7.3 Fodder discharge



- Completely open the discharge door when discharging very dry, long-stalk and highly-structured fodder.
- Extend the counter-cutter in front of the discharge opening a little into the mixing container to improve the homogeneous flow of the fodder material.
- If blockages occur during discharge, immediately switch the mixing auger off and eliminate the blockage.
- To throw off fodder residues from the mixing auger and to completely empty the mixing container towards the end, switch the mixing auger to quick motion mode (level II) for a short time.

WARNING



Risk of injury due to fodder or foreign objects being blown out and due to the running or extending and retracting side discharge conveyor (optional extra)!

Make sure that people and animals leave the hazardous area of the discharge opening and the side discharge conveyor!

1. Switch the mixing auger(s) to level I (Fig. 92).
2. When equipped with side discharge conveyor (optional extra):
 - 2.1 Swivel the side discharge conveyor out (Fig. 93).
 - 2.2 Switch the side discharge conveyor on (Fig. 94).
3. Slowly lift the dosage gate (Fig. 95).
4. Travel over the feeding table at an appropriate speed to ensure uniform fodder discharge.
5. Interrupt fodder discharge:
 - 5.1 Lower the dosage gate completely.
 - 5.2 Switch the side discharge conveyor (optional extra) off when the fodder discharge has been finished.
6. Finish fodder discharge:
 - 6.1 Switch the mixing auger(s) to level II (set manual throttle lever to maximum speed) for a short time if necessary for complete emptying.
 - 6.2 When the mixing container has been emptied, lower the dosage gate completely.
 - 6.3 Switch the side discharge conveyor (optional extra) off and swivel it in when the fodder discharge has been

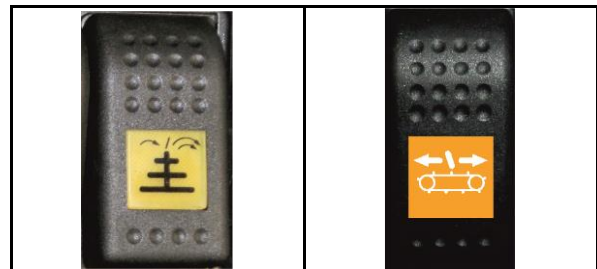

Fig. 92

Fig. 93

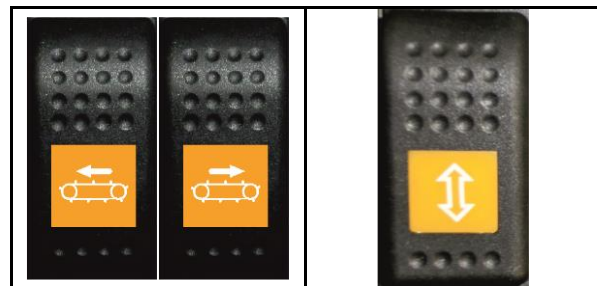

Fig. 94

Fig. 95

finished.

6.4 Switch the mixing auger(s) off.

7.3.1 Eliminate blockages

WARNING



Risk of injury when working in the discharge opening!

Secure the lifted dosage gate against accidental lowering!

Wear cut-proof protective gloves and use a device or tool to eliminate the blockage of the discharge opening!

1. Switch the mixing auger(s) off (Fig. 96).
2. Switch the side discharge conveyor (optional extra) off (Fig. 97).
3. Lift the dosage gate of the clogged discharge opening completely (Fig. 98).
4. Activate the parking brake (Fig. 99).
5. Turn the diesel engine off.
6. Pull the ignition key out.
7. Eliminate the clogging.
8. Start the machine.
9. Lower the dosage gate completely (Fig. 98).
10. Switch the side discharge conveyor (optional extra) on (Fig. 97).
11. Switch the mixing auger(s) to level I (Fig. 96).
12. Lift the dosage gate (Fig. 98).
13. Deactivate the parking brake (Fig. 99) and continue the discharge procedure.

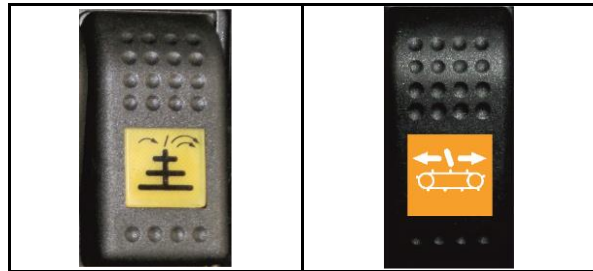

Fig. 96

Fig. 97

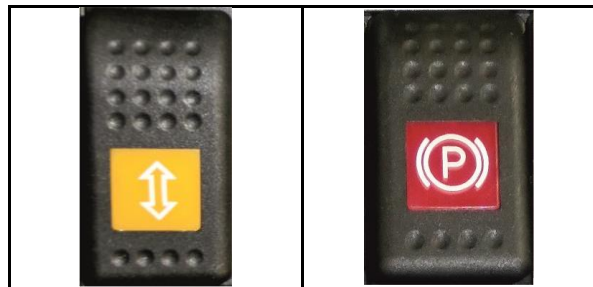

Fig. 98

Fig. 99

8 Service and maintenance of machine

Regular and proper service and maintenance:

- will keep your machine ready for use for a long time and avoid early wear,
- will reduce downtimes and repairs,
- is a precondition for our warranty provisions.



- When carrying out service and maintenance work on the machine, additionally observe the information included in the following chapters:
 - "**Operator's obligation**", page 23,
 - "**Qualification of operator**", page 24,
 - "**Basic safety instructions**", page 26,
 - "**Warning and instruction signs**", page 33.Observance of these chapters serves your safety.
- Immediately replace worn or damaged components.
- Only use original spare parts.
- Observe environmental protection measures when carrying out service and maintenance work on the machine.
- Observe legal provisions when disposing of operating media such as oils and greases. These legal provisions also apply to parts having come into contact with those operating media.
- In case of doubt, the maintenance intervals specified in the included sub-supplier documentation shall prevail.
- As a basic principle, disconnect all electrical/electronic plug-in connections before carrying out welding work on the machine!
- It is necessary to take protective measures such as covering power supply lines, hydraulic hose pipes, brake and feed lines or removal of such lines at particularly critical spots:
 - when carrying out welding, drilling and grinding work,
 - when carrying out work by means of cutoff wheels in the vicinity of these pipes and lines.
- Check brake lines, compressed air pipes and hydraulic hose pipes with special care for visible defects.



- Special know-how is required for carrying out testing and maintenance work. This know-how is not imparted by these operating instructions.
- The maintenance intervals depend on the frequency of use of your machine. The maintenance plan has been tailored to medium axle loads and stress exerted on the brakes.

In case of higher loads and amount of stress, maintenance work must be carried out at respectively shorter intervals. This shall in particular apply to the brakes and chassis.
- Modifications to the maintenance instructions shall be reserved!

8.1 Secure pick-up arm against accidental lowering

WARNING



Risk of injury due to movements of the machine or its working tools!

Secure the machine against accidental starting, rolling and actuation!

Insert mechanical support device

1. Lift the pick-up arm as far as to allow the mechanical support device (4) to be placed at the hydraulic cylinder of the pick-up arm.
 2. Switch the parking brake on.
 3. Turn the diesel engine off.
 4. Pull the ignition key out.
-
5. Unhook the spring hook (1) from the notch (2).



Fig. 100

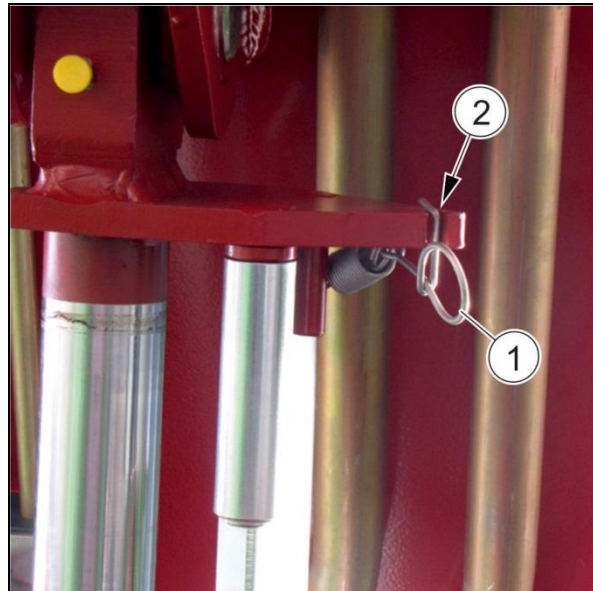

Fig. 101

6. Swivel the support (3) in direction "B" towards the hydraulic cylinder.
The mechanical support device is inserted. The pick-up arm is secured against accidental lowering.

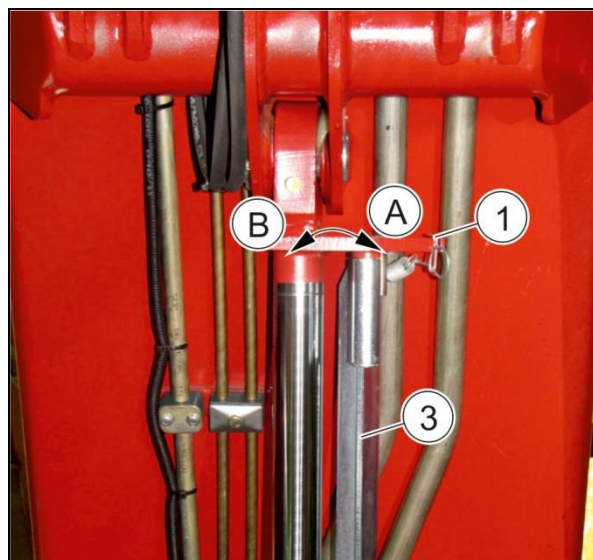

Fig. 102

Remove mechanical support device

1. Swivel the mechanical support (3) at the hydraulic cylinder of the pick-up arm back to transport position "A".

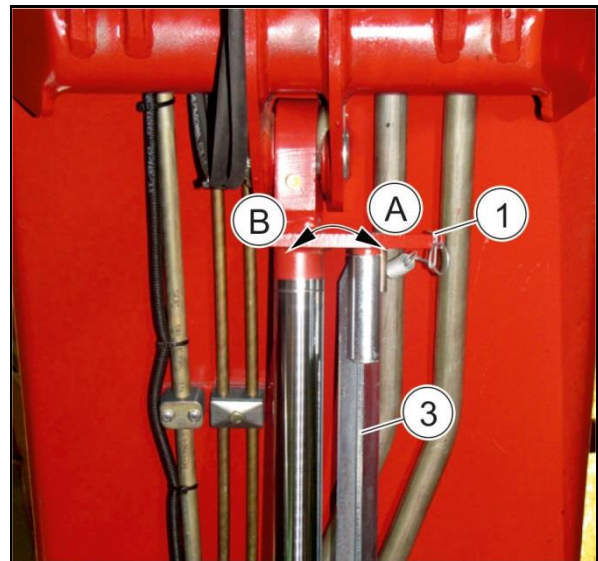

Fig. 103

2. Hook the spring hook (1) into the notch (2) to lock the mechanical support device.
3. The diesel engine can now be restarted and the pick-up arm can be lowered.

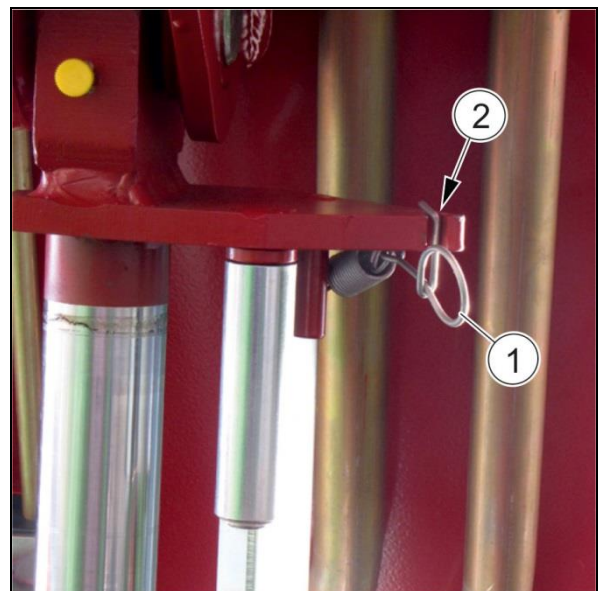

Fig. 104

8.2 Enter the mixing container

Shop work

WARNING

Risk of injury due to falling when climbing over the top edge of the mixing container without permission!

Only enter the mixing container through a discharge opening with the dosage gate completely lifted and secured against accidental lowering!

WARNING

Risk of injury due to slipping, stumbling or falling!

Only carry out work in an empty mixing container which is as clean and dry as possible!

Wear non-slip safety footwear!

Pay particular attention to the scraper(s) of the mixing auger(s) near the bottom!

WARNING

Risk of injury due to sharp cutting knives!

Rotate the mixing auger(s) such that the cutting knives are not directly pointed at the discharge opening through which you intend to enter the mixing container!

Wear cut-resistant protective gloves!

Cover the cutting knives by means of an edge protector!

DANGER

With magnetic system (optional extra): Danger to life to people with pacemakers and implanted defibrillators due to magnetic fields!

Keep sufficient distance to the magnets at the top and bottom at the mixing auger(s) if you wear a pacemaker or implanted defibrillator.

1. Rotate the mixing auger(s) such that the cutting knives are not directly pointed at the discharge opening through which you intend to enter the mixing container.
2. Completely open the discharge door of the discharge opening und secure it against accidental lowering.
3. Switch the parking brake on.
4. Turn the diesel engine off.
5. Pull the ignition key out.
6. Enter the mixing container through the open discharge opening.
7. Cover the cutting knives by means of the edge protector.
8. After completion of work in the mixing container: Clean the mixing container and remove loose components, tools etc. from the mixing container.
9. Leave the mixing container through the open discharge opening.

8.3 Operating media



Exclusively use the operating media specified in these operating instructions and in the included sub-supplier documentation!

The manufacturer will not assume any warranty or liability for damage on the machine caused by the use of non-approved operating media.

Filling-up point	Quantity when filled	Liquid / Lubricant	Specification	Trade name (manufacturer)
Lubrication points	s. p. 88	Grease	Lithium-saponified multi-purpose grease	Avialith 2EP
Milling drum gearbox	1 l	Gear lubricant oil	EP 80W-90, EP VG 220 (-30°C/+65°C)	MZ 80W (Avia) * EP B 80W-90 (Total) EP Plus SAE 80W-90 (Aral) Spirax A 90 LS (Shell)
Mixer gearbox	20 l			
Front brake driving axle	1.3 l + 14.5 l + 1.3 l			
Hydraulic oil tank	270 l	Hydraulic oil	Hydraulic oil according to DEXRON II D	Fluide ATX (Total) * ATF 22 (Aral) Autran DX II (BP) ATF D2 (Esso) Titan ATF 3000 (Fuchs) Donax TA (Shell)
			Biodegradable hydraulic oil	Forbex SE 46 (Aral) Biohyd SE-S 46 (BP) Mobil EAL Hydraulic Oil 46 (Esso/Mobil) Plantosyn 3268 (Fuchs) Naturelle HF-E 46 (Shell) Biohydran SE 46 (Total)
Fuel tank	140 l	Diesel fuel	Observe the latest specifications of the engine manufacturer!	
Engine oil tank	8.5 l	Engine oil	Observe the latest specifications of the engine manufacturer!	
Engine cooling system	19 l	Long-term coolant	Observe the latest specifications of the engine manufacturer!	

* Initially filled by the manufacturer

8.4 Service and maintenance plan - Overview

► See also chapter "Lubrication plan", page 88!



It is imperative to observe the included diesel engine operating instructions.



For maintenance work to be exclusively carried out by an authorised workshop, please refer to the inspection booklet.

The maintenance intervals specified in the included sub-supplier documentation shall prevail.

Before first start-up and after longer downtimes

Check:

- the machine for visible defects.
- all functions of the machine, including the engine function.
- all liquid filling-up points for tightness.
- all wheel nuts for tightness, retighten if necessary.
- all screwed connections of the chassis for firm seat.
- the hydraulic hoses and screwed connections for tightness and firm seat.
- the oil level of all gearboxes and axles.
- the tyre pressure.

Completely lubricate the machine.

After first startup

Check the screws of the holding-down plates of the Fast-Cut cutting knives (optional extra) for tightness (after the first 2 service hours, also after change of cutting knives); retighten the screws if necessary.

Daily

Check:

- the machine for visible defects.
- all functions of the machine, including the engine function.
- the service brake and the parking brake for proper functioning.
- the lighting system, horn (reversing signal) for proper functioning.
- the milling drum for imbalance, the milling blades for good fixture, position (especially the outer milling blades), wear, breakage and loss.
- the Fast-Cut cutting knives (optional extra) for proper contact with the counter-cutter; remove silage residues from the space between if necessary.
- the cutting knives of the mixing auger for good fixture, wear, breakage and fodder piling up.
- the strippers of the elevator conveyor.
- all conveyor belts for conveyor tension, conveyor run and damage (fissures, raised corners).

- rear-view camera and outside mirrors for proper setting, functioning and damage.
- all liquid filling-up points for tightness.
- all screwed connections of the chassis for firm seat.
- the hydraulic hoses and screwed connections for tightness and firm seat.
- the oil level of all gearboxes and axles.
- the tyre pressure.
- the tyres for damage and sufficient tread depth (minimum 2 mm).
- the level of the engine oil, coolant and hydraulic oil.

Clean:

- the air filter element.
- the cooling system for coolant, charge air, hydraulic oil (in case of difficult conditions even several times a day).

Regularly

Check:

- all conveyor belts (outside and inside), conveyor drive components (driving rollers, carrying rollers and pulleys), conveyor cover strips, conveyor bearings and bearing housings for contamination (bumps in the conveyor belt!), damage, proper seat and functioning.
- the central lubrication (optional extra) for proper functioning: Do all lubrication points have a sufficient grease collar? Is sufficient grease available in the reservoir? Top up the reservoir before the minimum level is reached!
- the Fast-Cut cutting knives (optional extra) for deformation and wear; readjust or replace them if necessary.
- the 6 mm slide plates of the Fast-Cut cutting knives (optional extra) for wear; turn them over (wear on one side) or replace them (wear on both sides) if necessary.
- the contamination indicator of the hydraulic oil return-flow filter (on the outside of the hydraulic oil tank) and of the hydraulic oil intake of the feed pump (in the engine compartment); replace the filters in case of extensive contamination (shop work!).
- electrical lines for damage and proper installation.
- batteries for sufficient charge.
- the distance between dosage gate and mixing container.
- the concentration of the anti-freezing agent in the coolant system (in winter).

Top up windscreen washing water.

Every 50 service hours

Check:

- all wheel nuts for tightness, retighten if necessary.
- the hydraulic hoses and screwed connections for tightness and firm seat.
- the fastening screws of the cutting unit guard (optional extra) for tightness; retighten them if necessary.

Every 100 service hours

Check:

- the gear lubricant oil level of the mixer gearbox.
- all screwed connections of the chassis for firm seat (once).

- the pick-up arm bearing for proper initial tension (520 Nm) (once, then every 500 service hours).

Clean fresh air filter and air circulation filter.

Change the oil in the milling drum gearbox (shop work!) (once, then every 2000 service hours).

Every 500 service hours

Check:

- wheel hub bearing and steering bearing for proper clearance,
- the milling drum or conveyor drum for wear and imbalance.
- the mixing auger for breakage, wear and fodder piling up.
- the pick-up arm bearing for proper initial tension (520 Nm) (once).
- the rear swing axle for proper clearance.

Clean the ventilation filter of the hydraulic system.

Every 2000 service hours, at least once a year

Replace fresh air filter and air circulation filter.

Change the oil in the milling drum gearbox (shop work!).

Before winter period

- Make sure that the antifreeze quantity is sufficient.

8.5 Preservation/Longer downtimes

Preparing the machine for longer downtimes shall include:

- thorough cleaning of machine,
- lubrication and greasing of machine,
- touching up of paintwork.

8.6 Cleaning of machine



- Regularly and thoroughly clean the machine! Dirt binds humidity thus causing rust formation.
- Observe the legal provisions for handling and disposal of cleaning agents.
- Never clean brake lines, air pipes and hydraulic hose pipes with benzine, benzol, paraffin or mineral oils.
- Lubricate the machine after cleaning, especially after cleaning by means of a pressure washer / steam blaster or fat-dissolving agents.

Cleaning by means of pressure washer / steam blaster

It is absolutely imperative to observe the following when using a pressure washer / steam blaster for cleaning.

- The maximum admissible injection pressure is 80 bar.
- The maximum admissible water temperature is 60°C.
- Do not clean electrical components such as control set, weighing rods, distributor boxes, weighing computer etc.
- Do not clean chromium-plated components.
- Never aim the cleaning nozzle jet of the pressure washer / steam blaster:
 - directly at lubrication points and bearings,
 - directly at hydraulic components.
 - directly at rubber gaskets.
- Always keep a minimum nozzle distance of 300 mm between the cleaning nozzle and the machine.
- Never aim the cleaning nozzle jet at the machine parts at right angles. The nozzle spray angle must at least be 25°.
- Do not use any chemical additives.
- Observe the safety instructions when handling pressure washers.

8.7 Lubrication of machine

Remove the dirt from the lubrication nipples before carrying out lubrication work.

Do not exceed the maximum lubrication pressure of 250 bar when using high-pressure grease guns! Damage to bearings, seals etc. may occur if the grease gun used is not equipped with a protective device.

Exclusively use lithium-saponified multi-purpose grease.

Use environmentally friendly, biodegradable oils and greases where lubricants may penetrate the fodder or the ground.

8.7.1 Lubrication plan

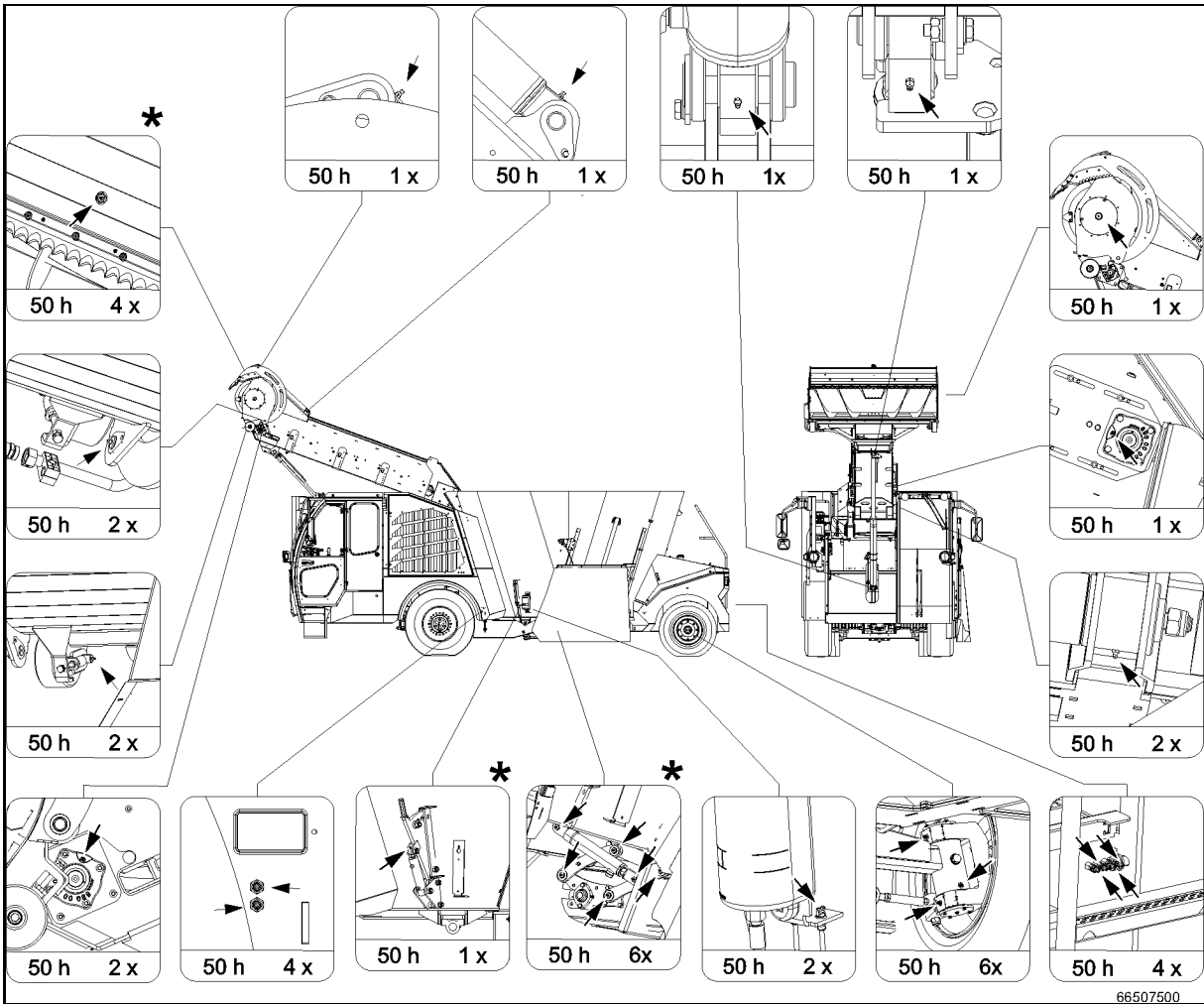

Fig. 105 * Optional extra

8.8 Refuelling



Top up the fuel tank at the end of each working day, thus avoiding that water condenses and freezes in frosty conditions.

DANGER



Burns due to igniting fuel or fuel vapours!

Only refuel with the diesel engine turned off and the ignition switched off.

Smoking and dealing with open fire are not allowed during refuelling.

Do not enter the driver's cabin during refuelling. The electrostatic charge may generate sparks!

1. Unlock the tank cap (1).
2. Unscrew the tank cap to the left.
3. Put the tank cap onto a clean surface.
4. Top the fuel tank up.
5. Screw the tank cap onto the tank filler neck to the right as far as it will go.
6. Lock the tank cap.

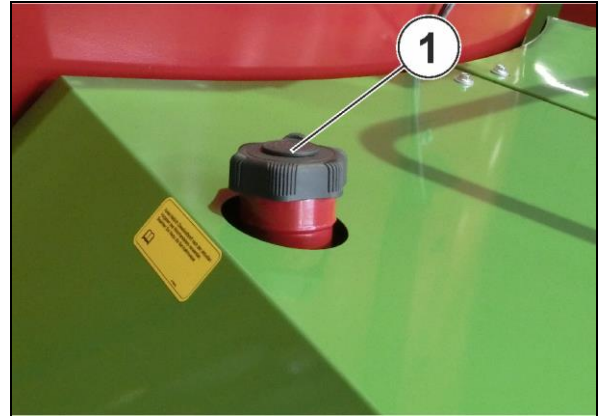

Fig. 106

8.9 Diesel engine - Check / Top up oil level



It is imperative to observe the included diesel engine operating instructions.

WARNING



Risk of burns if engine oil comes into contact with hot surfaces and ignites!

Let the diesel engine cool down before filling in engine oil.

Top up engine oil carefully in small quantities and by means of a funnel if necessary.

WARNING



Risk of injury due to movements of the machine or its working tools!

Secure the machine against accidental starting, rolling and actuation!

1. Park the machine on level, horizontal ground.
2. Lift the pick-up arm and secure it against accidental lowering by means of the mechanical support device (4).



Fig. 107

3. Turn the diesel engine off and wait 10 minutes for the engine oil to flow back into the oil tray.
4. Open the engine cowling (1).

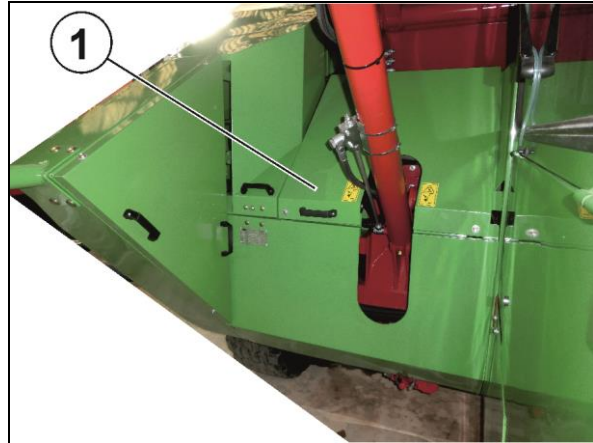

Fig. 108

5. Pull the oil-level dipstick (1) out and wipe it using a clean cloth.
6. Push the oil-level dipstick in again as far as it will go.
7. Pull the oil-level dipstick out again and read the oil level.

The oil level should always be between the top (X) and bottom marking (Y) of the oil-level dipstick (Fig. 110).

Top up engine oil if the oil level is at or below the bottom marking (Y).

8. Unscrew the cap (2) of the filler neck for the engine oil.
9. Top up engine oil in small quantities and check each time whether the oil level has already reached the top marking (X) of the oil-level dipstick.
10. Push the oil-level dipstick in again as far as it will go.

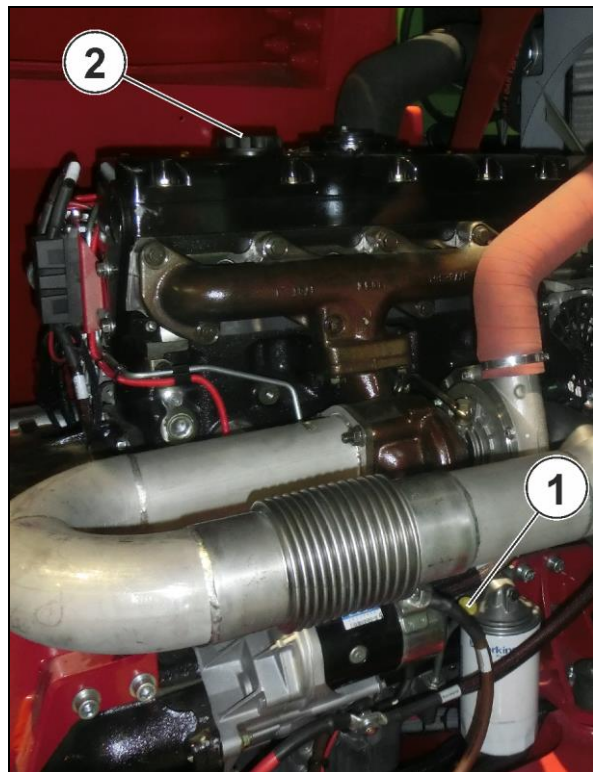

Fig. 109

11. Firmly screw the cap of the filler neck on again.
12. Close the engine cowling.

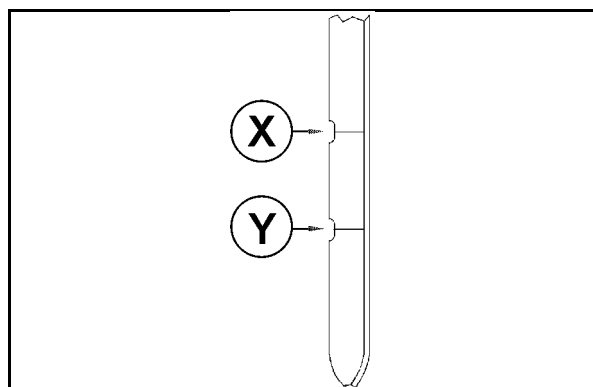

Fig. 110

8.10 Check / Top up coolant level



It is imperative to observe the included diesel engine operating instructions.

WARNING



Risk of scalds or burns due to hot coolant squirting out!

Open the cap of the coolant compensating reservoir only after the diesel engine has cooled down.

Use a thick cloth to generously cover the cap before opening.

Wear appropriate protective clothing (protective goggles, protective gloves).

1. Park the machine on level, horizontal ground.
2. Turn the diesel engine off and let it cool down.
3. Open the radiator door (1).



Close the cabin window before opening the radiator door, in order to avoid damage to the glass pane!



Fig. 111

4. Check the coolant level at the coolant compensating reservoir (2).
Top up coolant if the coolant level is below the middle line (3).
5. Use a thick cloth to generously cover the cap (4) of the coolant compensating reservoir and open the cap.
6. Top up coolant through the filler neck until the coolant compensating reservoir is filled up to $\frac{3}{4}$ of its volume.
7. Firmly screw the cap on again.
8. Close the radiator door.



Fig. 112

8.11 Check / Top up hydraulic oil level



Best check the hydraulic oil level at an hydraulic oil temperature of about 20°C.

As hydraulic oil expands when heated, topping-up of an excessive amount of hydraulic oil is thus prevented.



To avoid damage on the hydraulic system,

- only use hydraulic oils approved for the machine.
- never mix hydraulic oils of different specification groups or mineral and bio oils.
- keep hydraulic oils free from contamination by foreign objects or other liquids.

WARNING



Risk of injury due to movements of the machine or its working tools!

Secure the machine against accidental starting, rolling and actuation!

1. Park the machine on level, horizontal ground.
2. Read the hydraulic oil level at the level indicator tube of the hydraulic oil tank.
Top up hydraulic oil if the hydraulic oil level has dropped to minimum (1) at the latest.
3. Open the service cover above the hydraulic oil tank.
4. Unscrew the cap of the filler neck.
5. Top up hydraulic oil through the filler neck until the hydraulic oil tank is filled up to $\frac{3}{4}$ of its volume (2).
6. Firmly screw the cap of the filler neck on again.
7. Close the service cover.

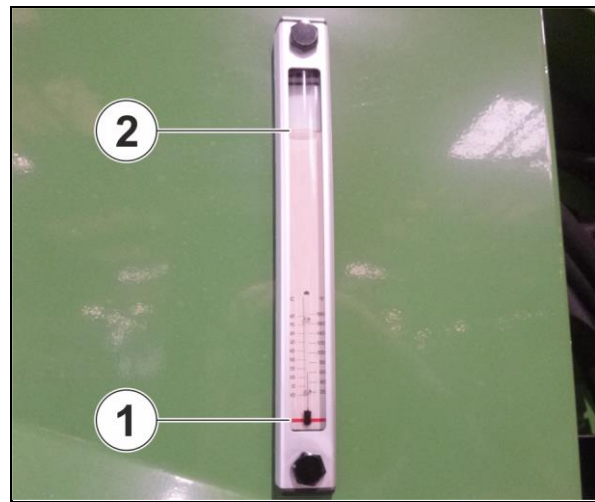

Fig. 113

8.12 Clean ventilation filter

WARNING



Risk of injury due to movements of the machine or its working tools!

Secure the machine against accidental starting, rolling and actuation!

1. Open the service cover (1) above the hydraulic oil tank.
2. Thoroughly clean the area surrounding the cap (2) of the filler neck.

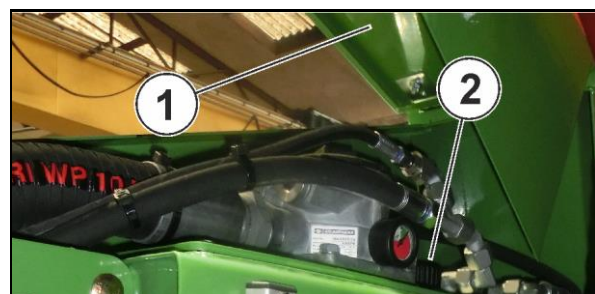

Fig. 114

3. Unscrew the cap (2) of the filler neck.
4. Remove the screws (3) and pull the ventilation filter (4) out of the filler neck.
5. Release the safety chain (5).
6. Use a cleaning spray or compressed air to clean the ventilation filter.
7. Fix the ventilation filter again at the safety chain.
8. Fix the ventilation filter again in the filler neck by means of the screws (3).
9. Firmly screw the cap of the filler neck on again.
10. Close the service cover.

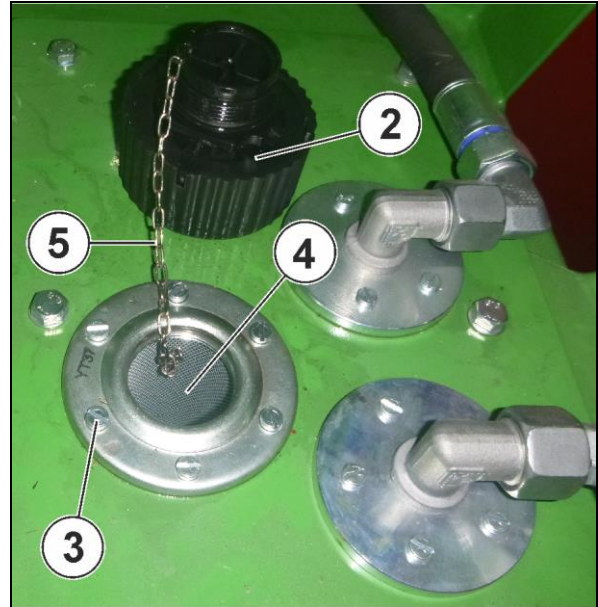

Fig. 115

8.13 Top up windscreen washing water



Exclusively use specialist windscreen washing water (including antifreeze if necessary), in order to avoid damage to the windscreen washer, e.g. choked nozzles.

Never add radiator antifreeze or other additives!

1. Open the radiator door (1).



Close the cabin window before opening the radiator door, in order to avoid damage to the glass pane!



Fig. 116

2. Open the cap (2) of the windscreen washing water container (3) and top up windscreen washing water.
3. Close the cap of the windscreen washing water container.
4. Close the radiator door.



Fig. 117

8.14 Replace wiper blades

1. Secure the machine against accidental starting and rolling.
2. Fold the wiper arm (1) off the windscreen.
3. Press and keep hold of the unlocking button (2) and simultaneously pull the wiper blade (3) in the direction of the arrow.
4. Slip a new wiper blade of the same length and design on until it engages.
5. Fold the wiper arm back to the windscreen.



Fig. 118

8.15 Clean / Replace air circulation and fresh air filter

Clean / Replace air circulation filter

1. Enter the driver's cabin.
2. Support the air circulation grid (1) from below while simultaneously turning the locks (3) clockwise by 90°.
3. Remove the air circulation grid and the air circulation filter (2) out of the cabin ceiling by moving them downwards.

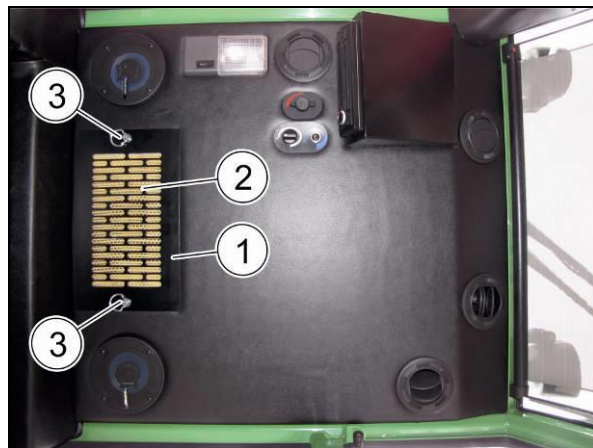

Fig. 119

4. Carefully beat out the air circulation filter (1) or use compressed air to blow it out from the inside to the outside.
5. Reinsert the air circulation filter and grid into the cabin ceiling and turn the locks (3) counterclockwise by 90°.

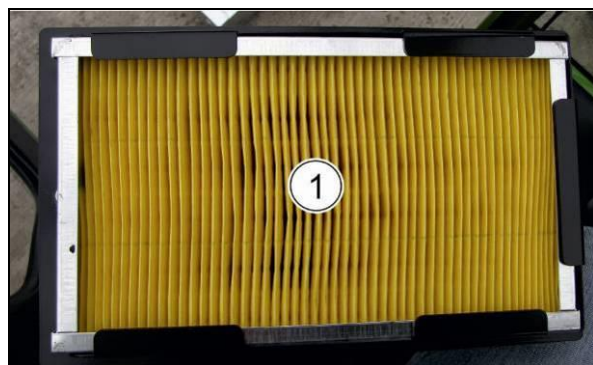

Fig. 120

Clean / Replace fresh air filter

1. Secure the machine against accidental starting and rolling.
2. Open the radiator door (1).



Close the cabin window before opening the radiator door, in order to avoid damage to the glass pane!



Fig. 121

3. Unscrew the screws (2) and remove the fresh air filter casing (3).

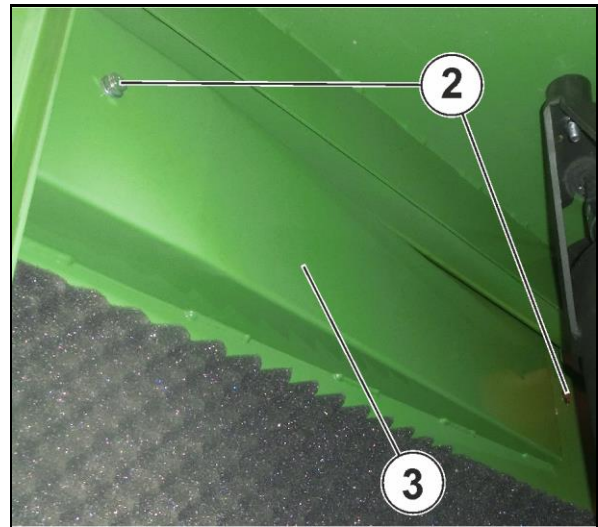

Fig. 122

4. Remove the fresh air filter (1) to the rear from the cabin's rear side.
5. Carefully beat out the fresh air filter or use compressed air to blow it out from the inside to the outside.
6. Reinsert the fresh air filter into the cabin's rear side.
7. Refasten the fresh air filter casing (3) at the cabin's rear side by means of the screws (2).
8. Close the radiator door.



Fig. 123

8.16 Check/Top up/Change gear lubricant oil

CAUTION



Risk of damage to machine components when powering gearboxes without gear lubricant oil!

Always ensure a sufficient oil level in the gearboxes.

WARNING



Risk of slipping to people due to leaking oil during topping-up of oil / oil change!

Immediately remove fresh oil stains by means of binding agents.



Check the gear lubricant oil level before starting the mixing process (optimum oil temperature: 0°C - 20°C). During the mixing process, the gear lubricant oil heats up and rises in the compensating reservoir.

Never mix synthetic oil with a mineral gear lubricant oil! This may damage the gearbox.

The approved gear lubricant oils are specified in the chapter "Operating media", page 83.



Dispose of used oil according to regulations. Contact your oil supplier in case of disposal problems!

8.16.1 Milling drum gearbox

1. Lower the pick-up arm to the ground.
2. Secure the machine against accidental starting and rolling.
3. Remove the protective cover of the milling drum gearbox (1).
4. Unscrew the oil inspection plug (2). The oil must be visible at the oil inspection plug.
5. Top up gear lubricant oil through the oil filler neck (3) if necessary.
6. Reinstall the protective cover of the milling drum gearbox.

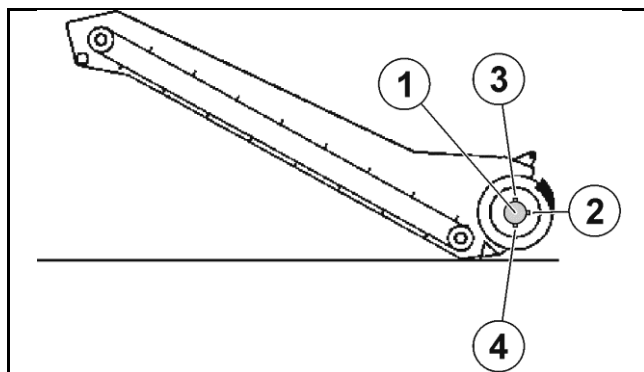

Fig. 124



Before having the gear lubricant oil changed (shop work!), the used oil must be drained and properly disposed of through the oil drain plug (4).

8.16.2 Mixer gearbox

1. Check the oil level in the mixer gearbox via the lateral compensating reservoir (1).
The oil level must be visible between the two filling level markings (2).
2. Top up gear lubricant oil if necessary after removal of the vent screw (3).

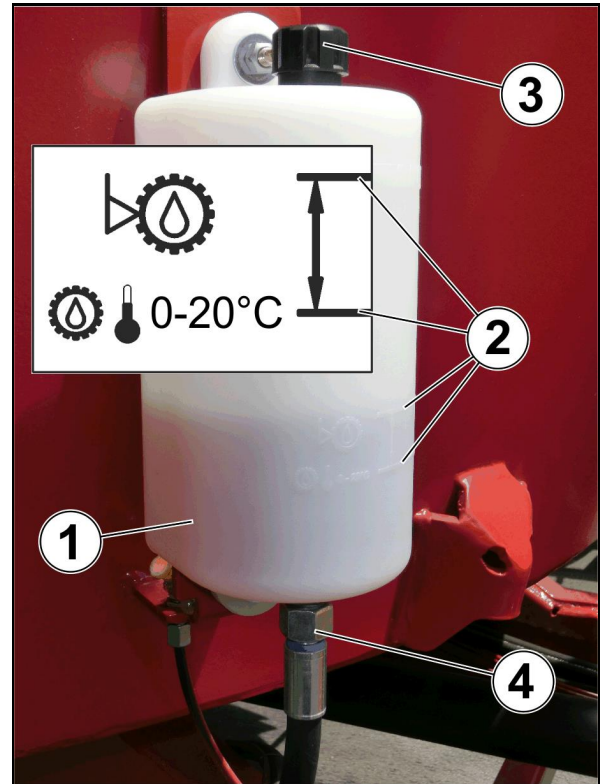

Fig. 125

8.17 Check / Adjust discharge door distance

1. Close the discharge door.
2. Secure the machine against accidental starting and rolling.
3. Measure the distance X between the discharge door and the mixing container. The distance must be approx. 5 mm.
4. Adjust the distance X if necessary:
 - 4.1 Unscrew the screws (1) at the L straps (2).
 - 4.2 Move the L straps (2) in the oblong holes such that the distance X is approx. 5 mm.
 - 4.3 Retighten the screws (1).

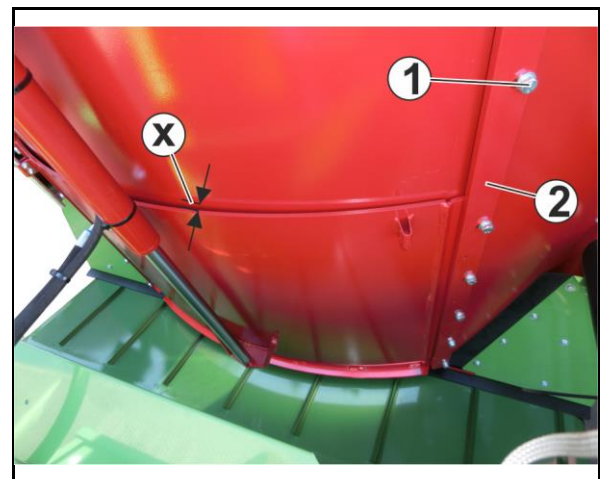



Fig. 126

8.18 Swivel / Replace cutting knives

Shop work

 Some cutting knives can be mounted in 2 positions:

- (1) **Retracted (factory setting):**
 - Requires less driving power.
 - Better undoing of bales.
- (2) **Extended:**
 - Requires higher driving power.
 - Supports discharge of highly-structured mixtures at the discharge opening.
 - An extended upper cutting knife can better pick up bale components and re-include them in the intensive mixing process.

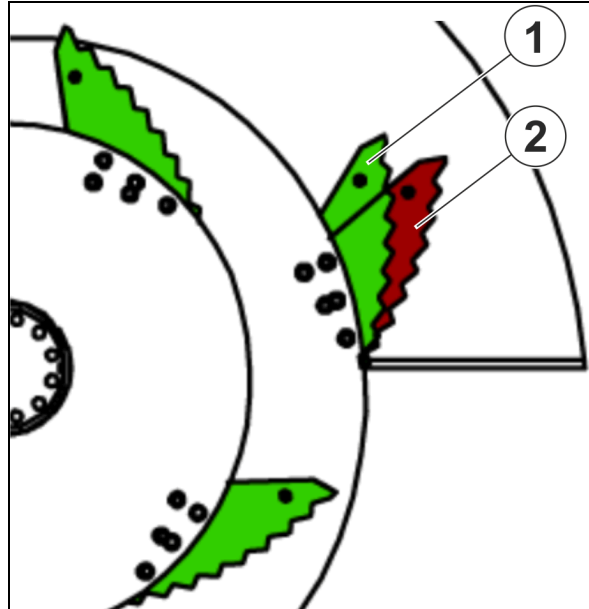



Fig. 127

DANGER



Risk of most serious injuries or even death due to movements of the machine or its working tools!

Secure the machine against accidental starting, rolling and actuation!

DANGER



With magnetic system (optional extra): Danger to life to people with pacemakers and implanted defibrillators due to magnetic fields!

Keep sufficient distance to the magnets at the top and bottom at the mixing auger(s) if you wear a pacemaker or implanted defibrillator.

WARNING



Risk of injury due to falling when climbing over the top edge of the mixing container without permission!

Only enter the mixing container through a discharge opening with the dosage gate completely lifted and secured against accidental lowering!

WARNING



Risk of injury due to sharp cutting knives!

Rotate the mixing auger(s) such that the cutting knives are not directly pointed at the discharge opening through which you intend to enter the mixing container!

Wear cut-resistant protective gloves!

Cover the cutting knives by means of an edge protector!

WARNING



Risk of injury due to slipping, stumbling or falling!

Only carry out work in an empty mixing container which is as clean and dry as possible!

Wear non-slip safety footwear!

Pay particular attention to the scraper(s) of the mixing auger(s) near the bottom!

1. Remove the screws (2).
 2. Swivel the cutting knife (1) or replace it.
- For the positions of the individual cutting knives, please refer to "Positions of cutting knives", page 100!

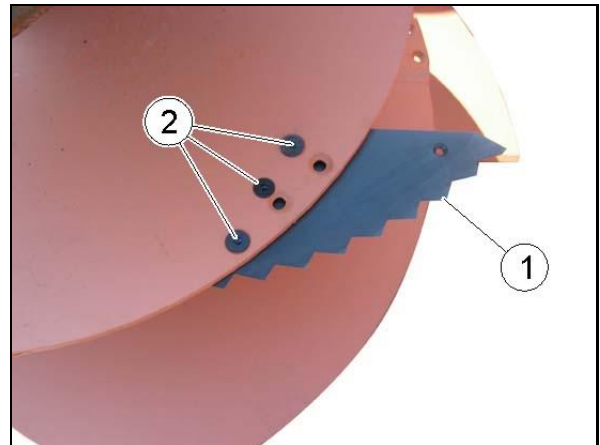

Fig. 128

Observe the fact that a knife supporting plate must be mounted beneath the top cutting knife of the mixing auger:

- a straight knife supporting plate (3) with the "Standard" and "Straw" set of knives.
- an angular bale knife supporting plate (5) with the "Bales" set of knives.



Fig. 129

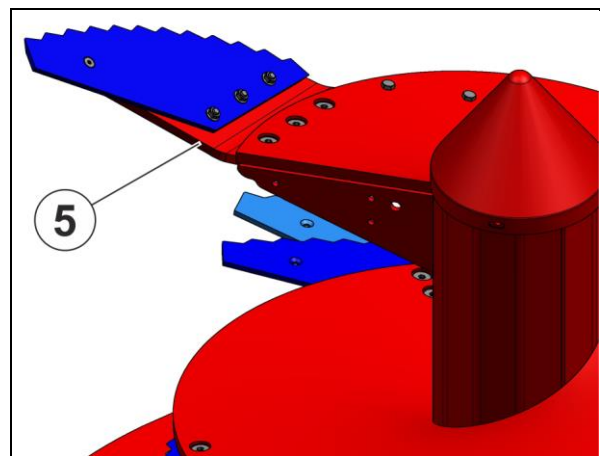

Fig. 130

3. Retighten the screws (2).
4. In addition to the cutting knives, a root crop knife (4) can be mounted onto the bottom end of the mixing auger.
5. Then remove all foreign objects (tools etc.) from the mixing container and thoroughly clean the container.

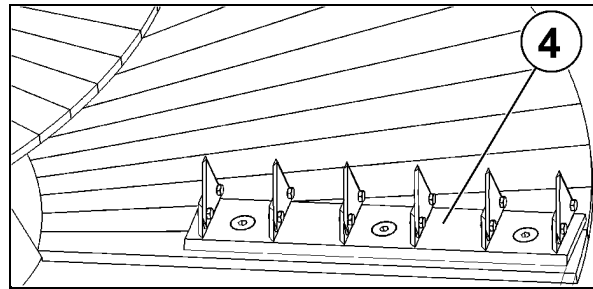

Fig. 131

Positions of cutting knives

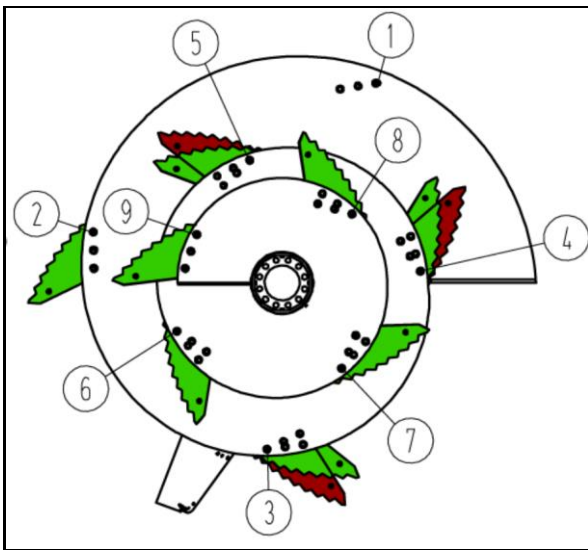

Fig. 132

Sherpa 1201, Sherpa 1401

Position \ Set of knives	Sherpa 1201, Sherpa 1401								
	(1)	(2)	(3) *	(4) *	(5) *	(6)	(7)	(8)	(9)
Standard	—								
Straw	—								
Bales	—								

= short cutting knife

= long cutting knife

* In these positions, extending of cutting knives is most effective.

8.19 Grind cutting knives

Shop work

DANGER

Risk of most serious injuries or even death due to movements of the machine or its working tools!

Secure the machine against accidental starting, rolling and actuation!

DANGER

With magnetic system (optional extra): Danger to life to people with pacemakers and implanted defibrillators due to magnetic fields!

Keep sufficient distance to the magnets at the top and bottom at the mixing auger(s) if you wear a pacemaker or implanted defibrillator.

WARNING

Risk of injury due to falling when climbing over the top edge of the mixing container without permission!

Only enter the mixing container through a discharge opening with the dosage gate completely lifted and secured against accidental lowering!

WARNING

Risk of injury due to sharp cutting knives!

Rotate the mixing auger(s) such that the cutting knives are not directly pointed at the discharge opening through which you intend to enter the mixing container!

Wear cut-resistant protective gloves!

Cover the cutting knives by means of an edge protector!

WARNING

Risk of injury due to slipping, stumbling or falling!

Only carry out work in an empty mixing container which is as clean and dry as possible!

Wear non-slip safety footwear!

Pay particular attention to the scraper(s) of the mixing auger(s) near the bottom!

WARNING

Risk of eye injury due to blown-away abrasive particles!

Wear protective goggles when carrying out grinding work!

Observe the safety instructions of your grinding machine!

1. Insert a flap grinding wheel into a right-angle grinder.
2. Carefully grind the cutting knives on their smooth top side.

Never regrind cutting knives on their corrugated underside!

Avoid overheating (discolouration) of the cutting knives during regrinding work! Overheating will reduce the service life of the cutting knives.

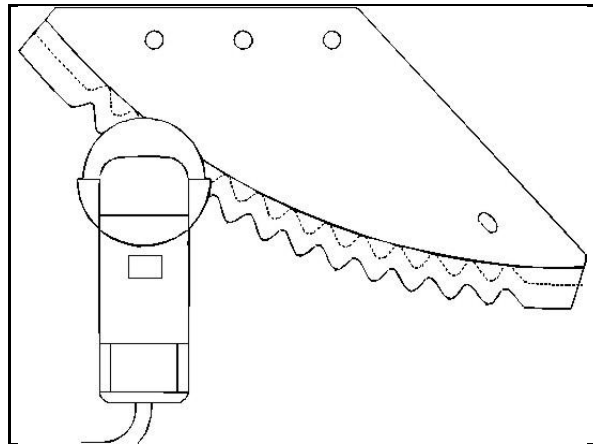

Fig. 133

3. Then remove all foreign objects (tools etc.) from the mixing container and thoroughly clean the container.

8.20 Tighten / Align side discharge conveyor

1. Secure the machine against accidental starting and rolling.
2. Unscrew the counter nut (1) at the right-hand and left-hand radial insert ball bearing (2).
3. Equally turn the two clamping nuts (3),
 - such that the side discharge conveyor sags by approx. 10 to 15 mm in its centre,
 - such that the distance A between the square profiles (4) and the clamping housing (5) is equal on both sides of the side discharge conveyor.
4. Carry out a test run to check whether the side discharge conveyor has an equal distance to the frame at the return rollers on both sides.

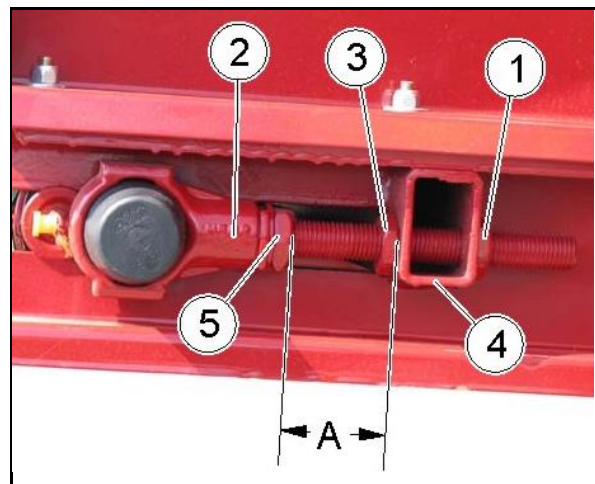

Fig. 134

Readjust the distance by turning the clamping nuts (3) if necessary.

5. Retighten the counter nut (1) at the right-hand and left-hand radial insert ball bearing (2).

8.21 Adjust supporting rollers

WARNING

Risk of injury due to movements of the machine or its working tools!

Secure the machine against accidental starting, rolling and actuation!

1. Lift the pick-up arm and secure it against accidental lowering by means of support trestles.

Carry out the following steps on both supporting rollers:

2. Unscrew the nut (1).
3. Unscrew the counter nuts (2).
4. Turn the nut (3) such that the supporting roller
 - moves forward and the distance between the milling drum/conveyor drum and the ground increases or
 - moves backwards and the distance between the milling drum/conveyor drum and the ground is reduced.
5. Retighten the counter nuts (2).
6. Retighten the nut (1) at a tightening torque of 400 Nm.



Fig. 135

8.22 Adjust scraper bar



The distance between the scraper bar and the ground should be approx. 5 mm.

1. Lift the pick-up arm and open the milling drum protection/the cutting unit.
2. Secure the machine against accidental starting and rolling.
3. Secure the lifted pick-up arm against accidental lowering by means of support trestles.
4. Unscrew or remove all screws (1) at the scraper bar (2).
5. Turn the scraper bar over if it is only worn on one side, and/or move the scraper bar:
 - forward to reduce the distance to the ground.
 - backwards to increase the distance to the ground.
6. Retighten all screws (1) at the scraper bar.

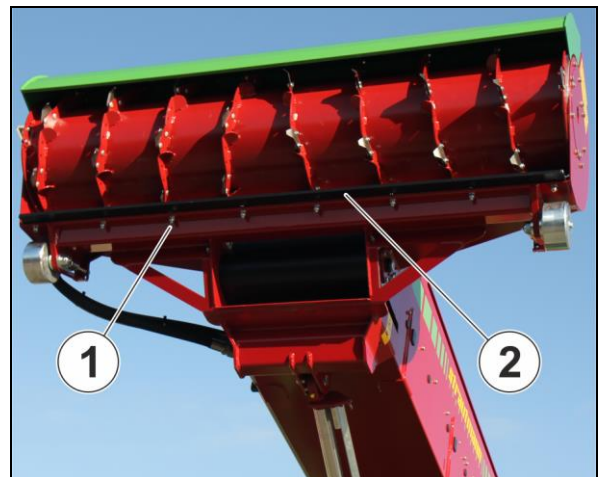

Fig. 136

8.23 Check tension of elevator conveyor

Check the tension of the elevator conveyor by means of the lateral control slit (1) in the pick-up arm:

The elevator conveyor is sufficiently tightened as long as it can be seen in the control slit (2).

Have the elevator conveyor retightened as soon as it can no longer be seen in the control slit (3) (shop work!).

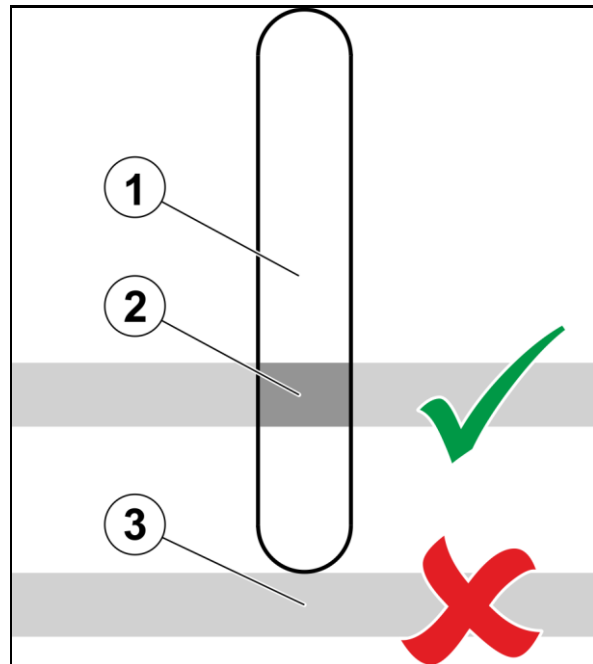

Fig. 137

8.24 Turn over / Replace milling blades of pick-up milling cutter

WARNING



Risk of injury due to sharp milling blades!

Wear cut-proof protective gloves when carrying out work on the milling blades.

Cover the milling blades by means of an edge protector.

1. Open the protective device of the pick-up milling cutter.
2. Secure the machine against accidental starting and rolling.
3. Carefully turn the milling drum by hand and check the condition of the milling blades.
4. Tighten the screwed connections of loose milling blades.
5. Turn over or replace worn milling blades.
 - 5.1 Unscrew the nuts and remove the screws.



Fig. 138

- 5.2 Replace the milling blades by new ones or exchange the milling blades on the left-hand and right-hand side of the pick-up milling cutter.
- 5.3 Tighten all screwed connections of the milling blades.
- 6. Close the protective device of the pick-up milling cutter.

8.25 Cutting unit

Optional extra

WARNING



Risk of injury due to cuts or amputation!

Wear cut-proof protective gloves when carrying out work on the cutting knives!

Only carry out work on the cutting knives after they have come to a standstill!

Secure the machine against accidental starting!

8.25.1 Check cutting unit

After the first 2 service hours (also after replacement of cutting knives):

Check the screws (5) of the holding-down plates for tightness.

Retighten the screws at 25 Nm if necessary.



Fig. 139

Check whether the cutting knives (3) properly fit the counter-blade (4) **every day**.

Remove silage residues having moved between the cutting knives and counter-blades.

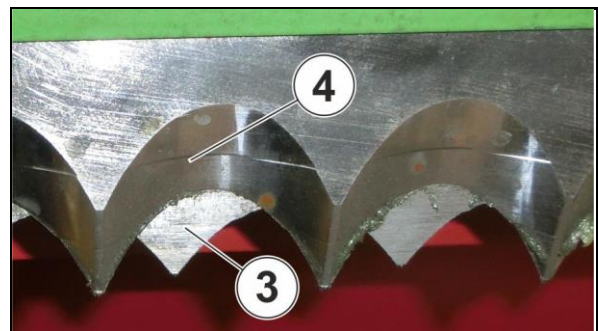

Fig. 140

Check the fastening screws (2) of the cutting unit guard for tightness **every 50 service hours**.

Retighten the screws if necessary.

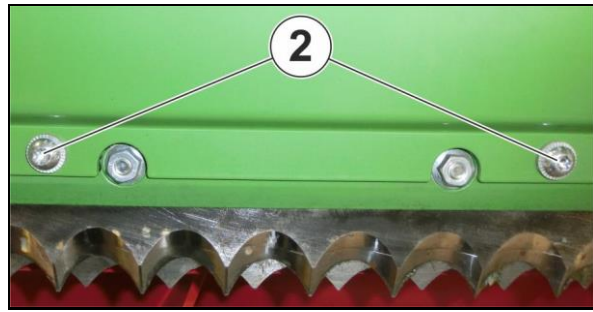

Fig. 141

Regularly check the blades for wear.

Replace the cutting knife if the blade (1) is worn or teeth have broken out.

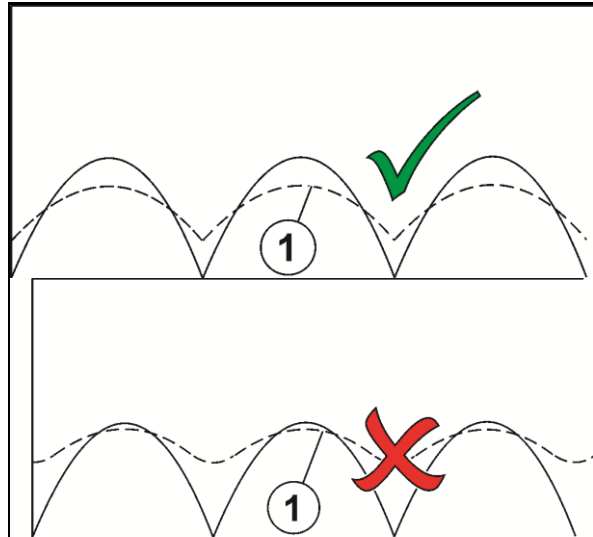

Fig. 142

Regularly check the cutting knives for deformation.

A serviceable cutting knife (1) has a slightly concave cross-section (distance $X = 0.2$ mm).

Readjust or replace the cutting knife if it is bent (2).

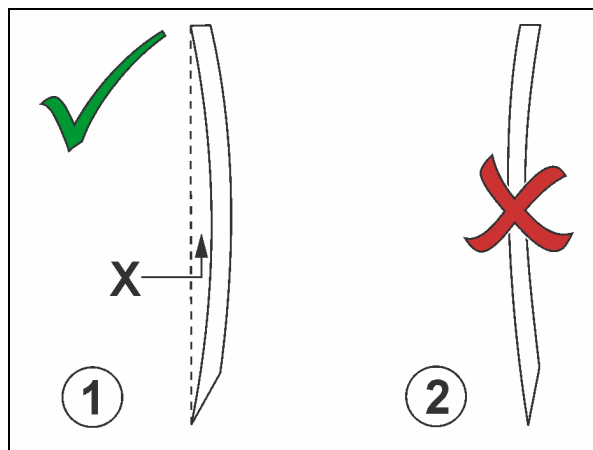

Fig. 143

Regularly check the 6 mm slide plates for wear.

Slide plates which are only worn on the underside (2) can be turned over and reinstalled.

Replace slide plates which are worn on both sides.

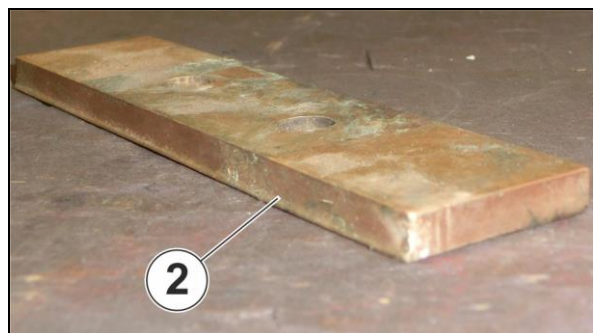

Fig. 144

8.25.2 Readjust Fast-Cut cutting knives

1. Detach the cutting knife.
2. Put the cutting knife with its contact surface facing upwards across the open jaws of a vice (Fig. 145, Fig. 146).

Make sure that not only the teeth of the cutting knife rest on the vice. Otherwise, the teeth may bend or break off.

3. Bring the cutting knife back to a slightly concave shape by means of hammer strokes (Fig. 143/1)



Fig. 145



Fig. 146

8.25.3 Replace Fast-Cut cutting knives and/or slide plates

Dismantle the desired parts in the following order:

- (1) Pusher cover
- (2) Holding-down plate
- (3) Fast-cut cutting knife
- (4) 1 mm slide plate
- (5) 6 mm slide plate
- (6) Slide strip
- (7) Counter-blade

For reinstalling, proceed in reverse order.

Tightening torque of all screwed connections:
25 Nm.

Check the screws of the holding-down plates for tightness **after the first 2 service hours**.
Retighten the screws if necessary.

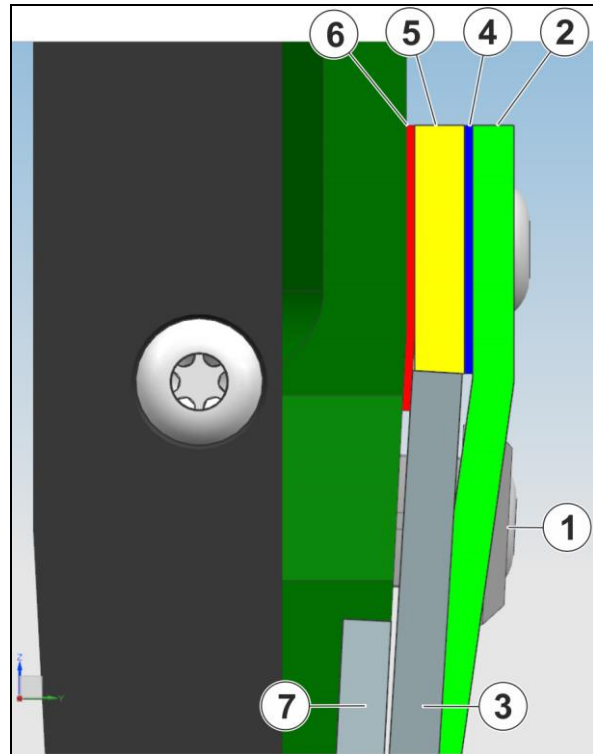

Fig. 147 Design of cutting unit (cross section)

8.26 Check hydraulic hose pipes

The marking on the fitting provides the following information:

- (1) Identification of the hydraulic hose pipe manufacturer (A1HF)
- (2) Date of manufacture of the hydraulic hose pipe (16/07 = year/month = July 2016)
- (3) Maximum admissible operating pressure (210 bar)

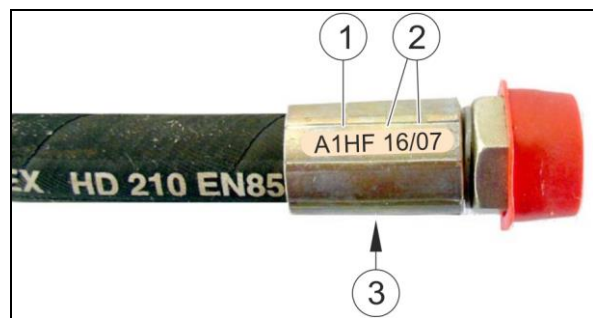

Fig. 148

For your own safety:

Immediately have hydraulic hose pipes replaced (shop work) as soon as you detect any of the following defects:

- Damaged outer layer down to the liner (e. g. due to chafing points, cuts, fissures).
- Embrittled outer layer (visible by cracking of hose material).
- Unnatural deformations of the hydraulic hose pipe in depressurized as well as in pressurized state or when bent (e. g. separation of layers, blistering, pinches, kinks).
- Leaks.
- Damaged, deformed or leaking fitting. Small surface damage is no reason for replacement.
- Hose slipping out of the fitting.
- Corroded fitting which may affect the function and the strength.
- Improperly laid hydraulic hose pipes, e. g. ignored bending radii, laying over sharp edges.
- The period of use of 6 years has been exceeded.

8.27 Wheel change

WARNING

Risk of crushing due to the lifted machine accidentally coming down!

Only lift the machine on firm, even ground. Use load-distributing supports if necessary.

1. Secure the machine against accidental starting and rolling.
2. Lift the machine at one of the marked application points (Fig. 149).
3. Secure the machine against accidental lowering by means of support trestles.
4. Remove the wheel nuts.
5. Remove the defective wheel and mount the new wheel.

Tighten the wheel nuts crosswise at the required tightening torque.
Front axle (M22 x 1.5): 650 Nm
Rear axle (M18 x 1.5): 270 Nm
6. Check the wheel nuts for tightness after 10 service hours. Retighten wheel nuts if necessary

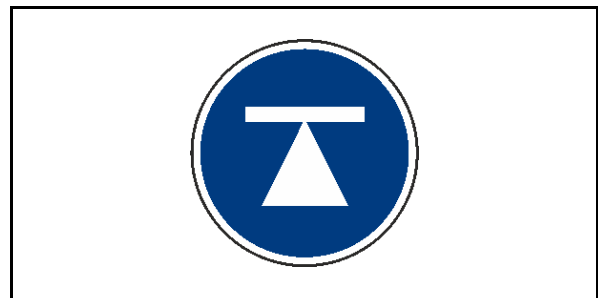

Fig. 149

8.28 Tightening torques for screwed connections



These tightening torques are reference values. Differing data specified elsewhere in the operating instructions or the included sub-supplier documentation shall always prevail!

Grade and marking of screw heads		4.8		8.8		10.9		12.9								
Grade and marking of nuts																
Size	Grade 4.8				Grade 8.8				Grade 10.9				Grade 12.9			
	lubricated*		dry **		lubricated*		dry **		lubricated*		dry **		lubricated*		dry **	
	Nm	lb-ft	Nm	lb-ft	Nm	lb-ft	Nm	lb-ft	Nm	lb-ft	Nm	lb-ft	Nm	lb-ft	Nm	lb-ft
M6	4.8	3.5	6	4.5	9	6.5	11	8.5	13	9.5	17	12	15	11.5	19	14.5
M8	12	8.5	15	11	22	16	28	20	32	24	40	30	37	28	47	35
M10	23	17	29	21	43	32	55	40	63	47	80	60	75	55	95	70
M12	40	29	50	37	75	55	95	70	110	80	140	105	130	95	165	120
M14	63	47	80	60	120	88	150	110	175	130	225	165	205	150	260	190
M16	100	73	125	92	190	140	240	175	275	200	350	255	320	240	400	300
M18	135	100	175	125	260	195	330	250	375	275	475	350	440	325	560	410
M20	190	140	240	180	375	275	475	350	530	400	675	500	625	460	800	580
M22	260	190	330	250	510	375	650	475	725	540	925	675	850	625	1075	800
M24	330	250	425	310	650	475	825	600	925	675	1150	850	1075	800	1350	1000
M27	490	360	625	450	950	700	1200	875	1350	1000	1700	1250	1600	1150	2000	1500
M30	675	490	850	625	1300	950	1650	1200	1850	1350	2300	1700	2150	1600	2700	2000
M33	900	675	1150	850	1750	1300	2200	1650	2500	1850	3150	2350	2900	2150	3700	2750
M36	1150	850	1450	1075	2250	1650	2850	2100	3200	2350	4050	3000	3750	2750	4750	3500

* "Lubricated" means that the screws are treated with a lubricant such as e.g. engine oil, or that phosphatized or oiled screws are used.

** "Dry" means that normal or galvanized screws without any lubrication are used.



- Regularly check the screwed connections for tightness.
- Always replace screws and nuts by parts of the same quality.
- Tighten counter nuts with plastic insert and bordered steel counter nuts at approx. 50% of the “dry” value specified in the table.
- Tighten gear or crown nuts at full torque.
- Shear bolts are designed such that they shear off (break) at a certain stress. Only use bolts of equal quality when replacing shear bolts.

8.29 Adjust travelling height of hydraulic chassis

Optional extra



The rear chassis can be best lowered with the machine charged.
If the machine is empty, press the pick-up arm down to the ground by means of the joystick to lower the rear chassis.

WARNING



Risk of injury due to movements of the machine or its working tools!

Secure the machine against accidental starting, rolling and actuation!

1. Pull the lever of the three-way cock (1) out and swivel it, until it engages,
 - to the upper position (2) to preselect the front chassis,
 - to the lower position (3) to preselect the rear chassis.
2. Start the machine.

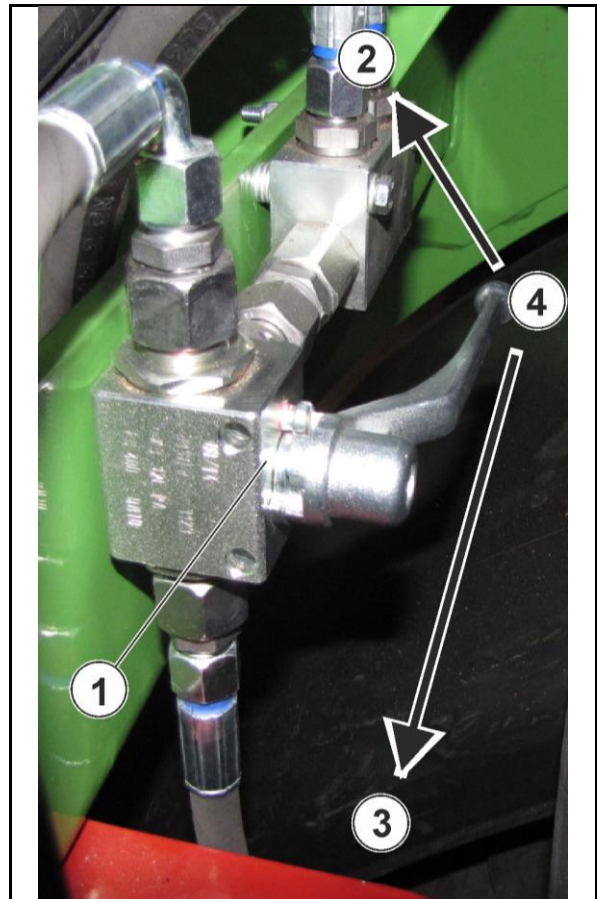

Fig. 150

3. Keep the rocker switch for the milling drum protection/cutting unit (2) at the joystick pressed.
 - The milling drum protection/the cutting unit swivels to its end position, then the preselected chassis lifts or lowers.
4. Turn the diesel engine off.

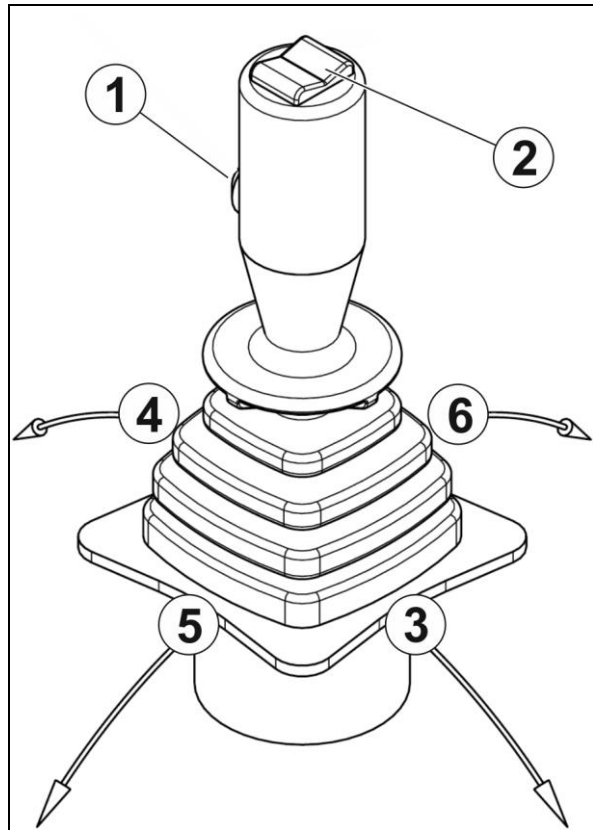

Fig. 151

5. Pull the lever of the three-way cock (1) out and swivel it until it engages in horizontal position (4).
 - The three-way cock is closed.

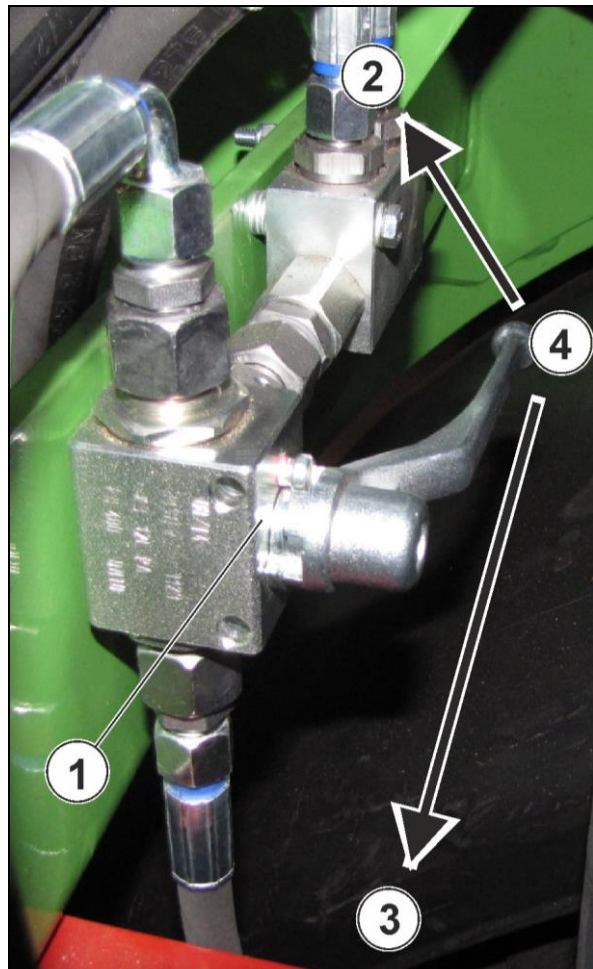

Fig. 152

8.30 Check / Top up central lubrication

Only use lithium-saponified multi-purpose grease of NLGI class 2.

Only use grease of the same saponifying criteria.

Check the filling level in the grease container (1) before each use. The level must not fall below 1 cm. Top up the container of the central lubrication early enough.

Only top up the container via the lubricating nipple (2). Ensure utmost cleanliness.

Keep the cover (3) of the container always closed, thus ensuring that the grease is permanently protected against the entry of water.

Regularly check the feed lines to the lubrication points for damage or break-off.

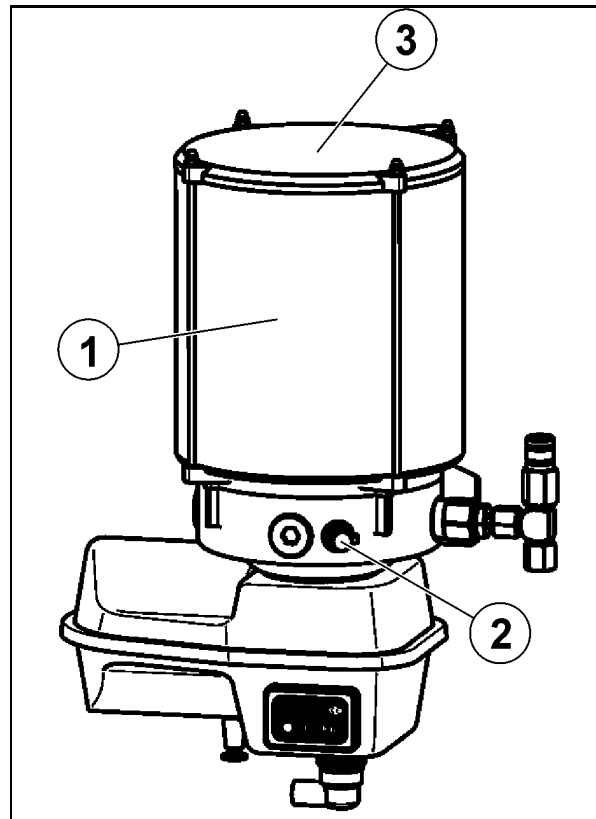

Fig. 153

9 Remedy of malfunctions

9.1 Start diesel engine by means of a jumper battery



- The jumper battery must provide a voltage of 24 volts and about the same capacity (Ah) as the machine battery.
- Always use a jumper cable with insulated pole pliers and a cross-section from 35 mm².
- After having connected the machine battery and the jumper battery with each other, immediately start the diesel engine, in order to prevent the jumper battery from being discharged.

Avoid damage to the electrical system due to short-circuit:

- Before connecting the jumper and machine battery, beware of correct polarity. Always connect plus pole (+) with plus pole (+) and minus pole (-) with minus pole (-).
- Ensure that the jumper cable connected to the plus pole (+) does not come into contact with electroconductive machine parts.

WARNING



Risk of explosion due to battery gases, caused by sparking and open fire in the vicinity of batteries!

Avoid sparking and open fire in the vicinity of batteries.

- Ensure that the non-insulated parts of the pole pliers of the jumper cable do not come into contact with each other.
- Make sure to always connect the minus pole (-) jumper cable last and remove it first when connecting the jumper cables.

WARNING



Risk of injury due to movements of the machine or its working tools!

Secure the machine against accidental starting, rolling and actuation!

1. Connect a plus pole (+) and a minus pole (-) of the two jumper batteries with each other to produce the required voltage of 24 V (Fig. 154)
2. Connect one end of the red jumper cable with the plus pole (+) of the jumper battery.
3. Connect the other end of the jumper cable with the plus pole (+) of the machine battery connected to the starter.

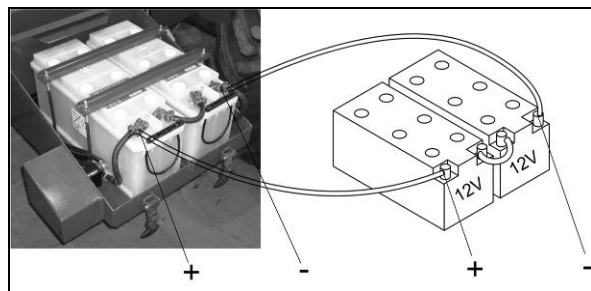

Fig. 154

4. Connect one end of the black jumper cable with the minus pole (-) of the jumper battery.
5. Connect the other end of the jumper cable with the minus pole (-) of the machine battery.
6. Start the diesel engine.
7. Immediately remove the jumper cables as soon as the diesel engine starts. Always disconnect the jumper cable first from the minus pole (-).

9.2 Tow machine



Avoid damage to the machine's traction drive by

- opening the **hydraulic oil circuit of the traction drive** (free oil circulation) before towing the machine, such that the traction drive no longer acts as auxiliary brake.
- **manually releasing the parking brake** before towing the machine.
- limiting the towing procedure to the **shortest possible distances** (e.g. clearing a crossing, not more than 1 km of travelling distance!).
- towing the machine not faster than at **walking pace**.
- paying attention to heat development in the traction drive.
- restarting the traction drive only **after complete filling and venting** of the hydraulic oil circuit; otherwise, unintentional functions may occur.

9.2.1 Open hydraulic oil circulation system of traction drive

WARNING

Risk of injury due to movements of the machine or its working tools!

Secure the machine against accidental starting, rolling and actuation!

Machine with milling drum

1. Turn the diesel engine off.
2. Remove the plastic safety caps of the pressure limiting valves (1) at the hydraulic pump of the traction drive. The safety caps are destroyed when being removed.
3. Use a hexagon key (SW 5) to loosen the screws of the pressure limiting valves by 2 turns to the left.
 - The hydraulic oil circulation system of the traction drive is open.
4. Manually release the parking brake (see chapter "Manual release of parking brake"), before towing the machine.
5. Retighten the screws at the pressure limiting valves at a tightening torque of 10 Nm after completion of the towing procedure.

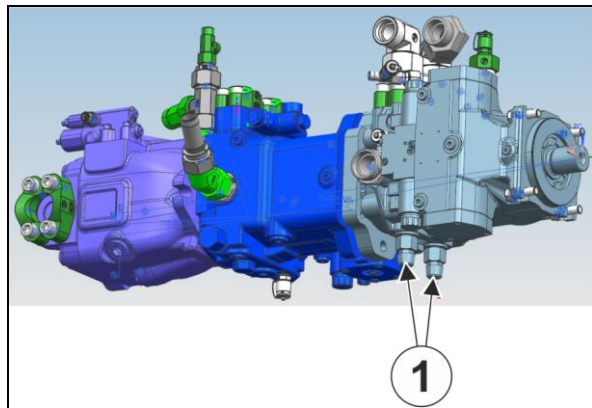

Fig. 155

Machine with Fast-Cut cutting unit (optional extra)

1. Turn the diesel engine off.
2. Unscrew the screw at the front (1) and rear (2) at the pressure limiting valves of the hydraulic pump of the traction drive by exactly 4 counterclockwise turns.
 - The hydraulic oil circulation system of the traction drive is open.
3. Manually release the parking brake (see chapter "Manual release of parking brake"), before towing the machine.
4. Retighten the screws at the pressure limiting valves at a tightening torque of 60 Nm after completion of the towing procedure.

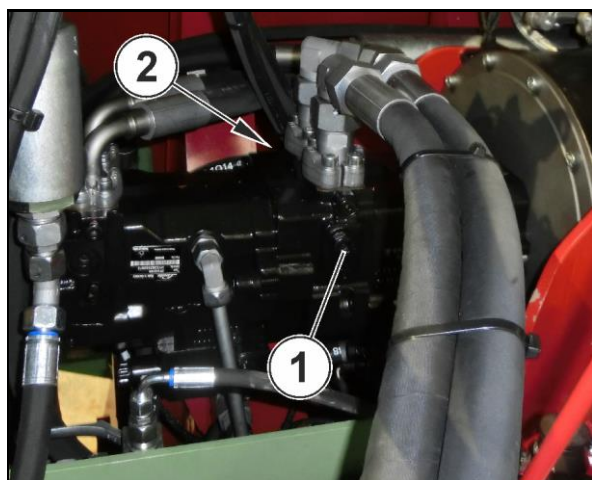

Fig. 156

9.2.2 Manual release of parking brake



In case of a failure of the hydraulic pressure supply, the machine is automatically slowed down by means of the parking brake.

In this case, the parking brake cannot be deactivated by means of the switch in the control console.

Manually release the parking brake to move the machine.

WARNING



Risk of injury due to movements of the machine or its working tools!

Secure the machine against accidental starting, rolling and actuation!

1. Unscrew the 6 Allen screws (1) at the casing of the differential gear (4).

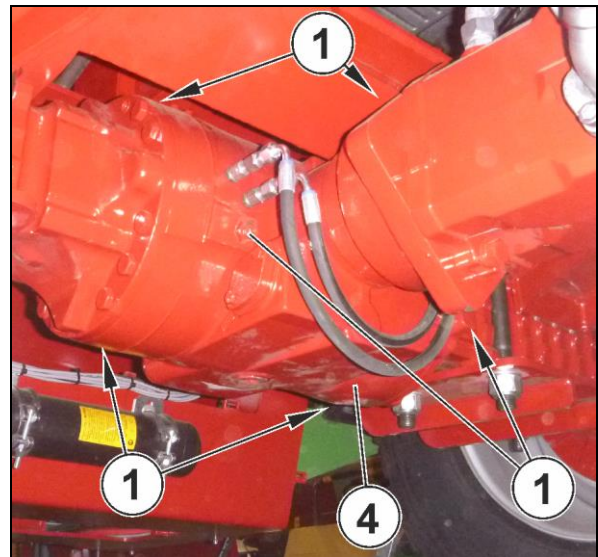

Fig. 157

The hexagonal head screws (2) must not be removed.

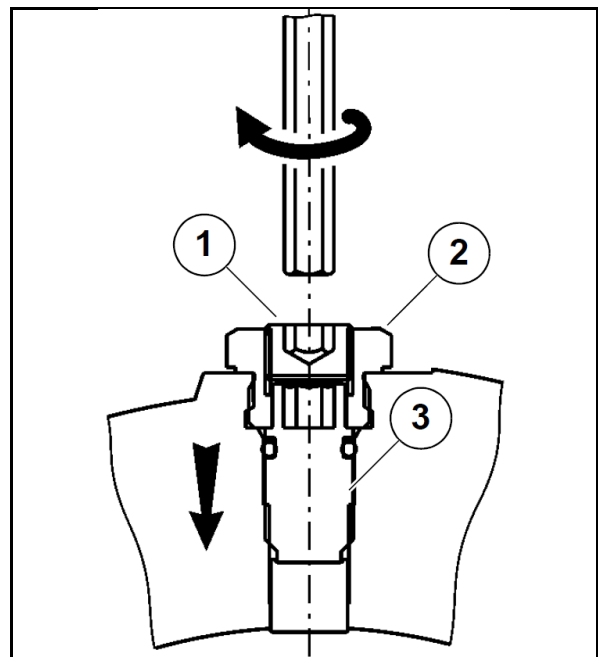

Fig. 158

2. Screw in the brake release bolts (3) in the order from top (A), front (B) to rear (C) by half a turn each until the resistance noticeably decreases (approx. 4-5 turns).
3. Have the parking brake, which was manually released, applied again by an authorised workshop after having manoeuvred or towed the machine.

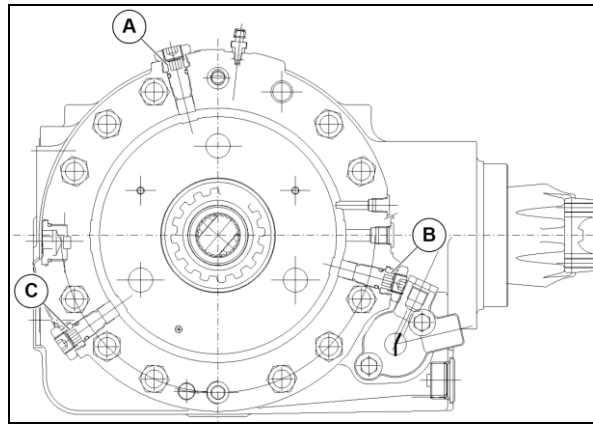

Fig. 159

9.3 Emergency manual operation in case of failure of electrical system

WARNING



Risk of injury due to movements of the machine or its working tools!

Secure the machine against accidental starting, rolling and actuation!

Use a blunt object (2) ($\varnothing \leq 3 \text{ mm}$) to push in the armature of the solenoid at the control valve (1) for the desired hydraulic function.



Never use a sharp-edged object to actuate the proportional solenoids (3).

A sharp-edged object may damage the borehole in the proportional solenoids. A damaged borehole may cause leakages of the proportional solenoids.

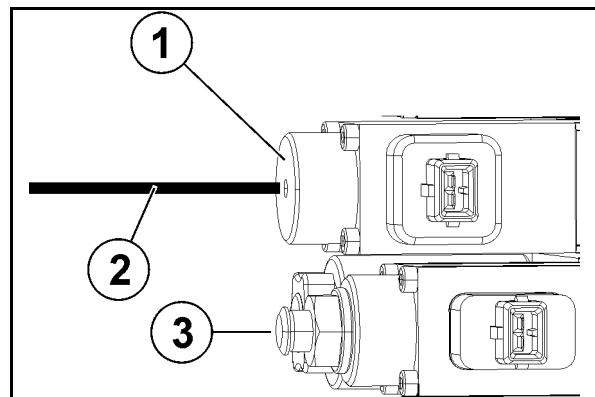

Fig. 160

9.4 Lift pick-up arm via emergency lifting device



The pick-up arm can be lifted via the emergency lifting device in the event of a failure of the electrical or the control system and the lowered pick-up arm impairs access to the central electrical system.

The emergency lifting device only works if the power supply to the ignition starter switch is not interrupted (ignition can be switched on).

WARNING



Risk of injury due to movements of the machine or its working tools!

Secure the machine against accidental starting, rolling and actuation!

1. Open the stop-cock (1) for the emergency lifting operation.



For technical reasons, the states "open" and "closed" may be assigned in another way than usual.

In any case, the factory setting of this stop-cock is "closed".

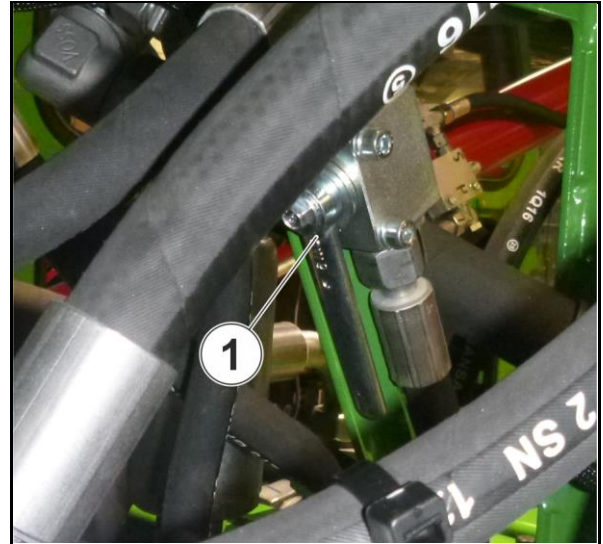

Fig. 161

2. Swivel the three-way cock (2) for the pick-up arm to the rear (3).
3. Actuate the starter via the ignition starter switch.
4. Turn the steering wheel (hard to turn!) to its right or left end position.
 - The pick-up arm rises.

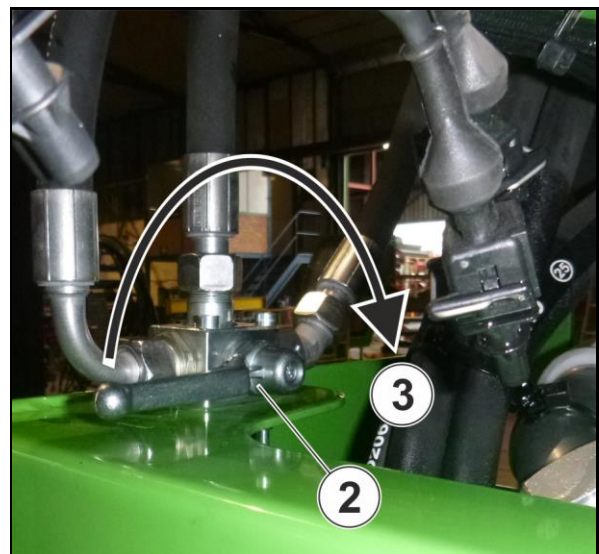

Fig. 162

5. Secure the lifted pick-up arm against accidental lowering by means of the mechanical support device (4).



Fig. 163

Before returning to normal operation mode:

6. Swivel the three-way cock (2) for the pick-up arm back to the front (6).
7. Swivel the stop-cock (1) for the emergency lifting operation back to its initial position "closed".
8. Remove the mechanical support device of the pick-up arm.

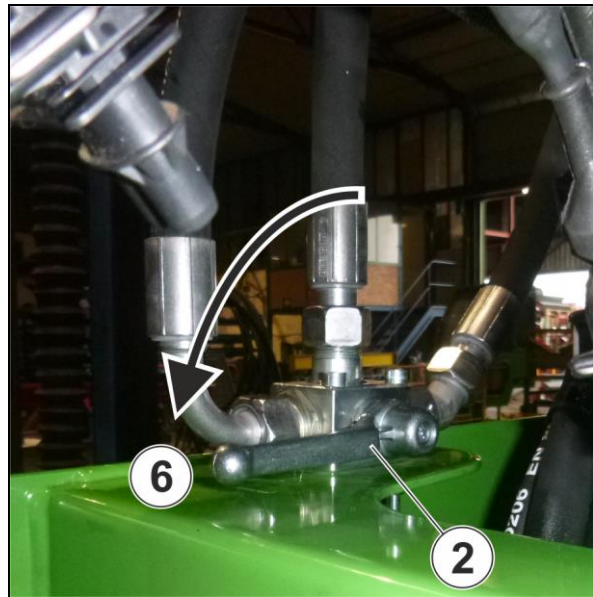

Fig. 164

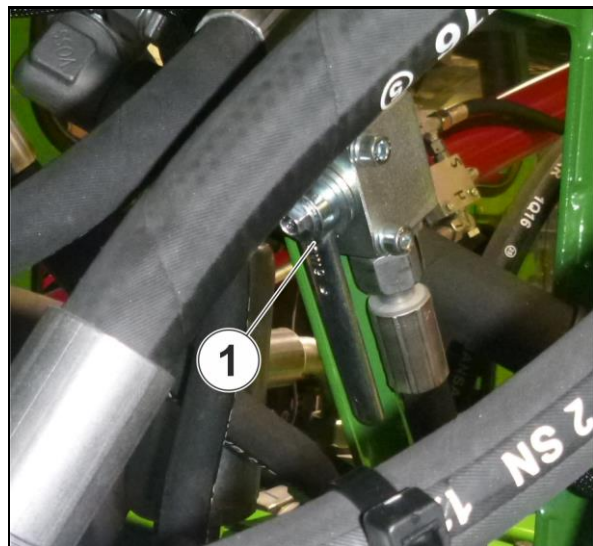

Fig. 165

9.5 Overview of other malfunctions and remedial actions



It is imperative to observe the included diesel engine operating instructions.

Malfunction	Cause	Remedy
Ignition starter switch does not work	Fuse defective	Replace fuse
	Battery main switch switched off	Switch battery main switch on
Terminal does not work	Fuse defective	Replace fuse

Malfunction	Cause	Remedy
Diesel engine starts badly or not at all	Air in fuel system	Bleed fuel system / Check screwed connections
	Fuel filter soiled	Replace fuel filter
Diesel engine has too less power	Air filter soiled	Clean or replace air filter
	Charge-air cooler soiled	Clean charge-air cooler
	Fuel filter soiled	Replace fuel filter
	Air in fuel system	Bleed fuel system / Check screwed connections
Machine does not start	Hydraulic oil level too low	Top up hydraulic oil
Excessive hydraulic oil temperature	Hydraulic oil level too low	Top up hydraulic oil
	Hydraulic oil cooler soiled	Clean hydraulic oil cooler
Pick-up arm only moves jerkily	Hydraulic pressure accumulator defective	Replace hydraulic pressure accumulator (shop work)
Power requirement too high	Cutting knives of mixing auger blunt	Sharpen or replace cutting knives
	Long stalks wrapped around the bottom end of mixing auger or scraper	Clean mixing auger
	Screwed connection of the mixing auger loosened	Retighten screwed connection
Poor mixing result	Fodder is piling up in front of counter-cutters	Extend and retract counter-cutters
Non-uniform discharge	Bottom cutting knife of mixing auger retracted	Extend bottom cutting knife
Difficult picking-up of silage	Milling blades loosened or worn	Retighten screws or replace milling blades
	Holding-down plates of Fast-Cut cutting knives (optional extra) loosened	Retighten screws of holding-down plates
	Insufficient lubrication of Fast-Cut cutting knives (optional extra)	Lubricate cutting knife bearing
	Fast-Cut cutting knives (optional extra) deformed, noticeable by silage residues between cutting knives and counter-blades	Readjust or replace cutting knives

10 Disassembly / Disposal

Shop work

WARNING



Risk due to overturning or falling machine parts and operating media harmful to environment and health!

Only qualified staff is allowed to disassemble the machine.

Machine parts and operating media (oils, greases etc.) must be disposed of in accordance with national and international environmental regulations.

11.1.2 Pump hydraulics

Machine with milling drum

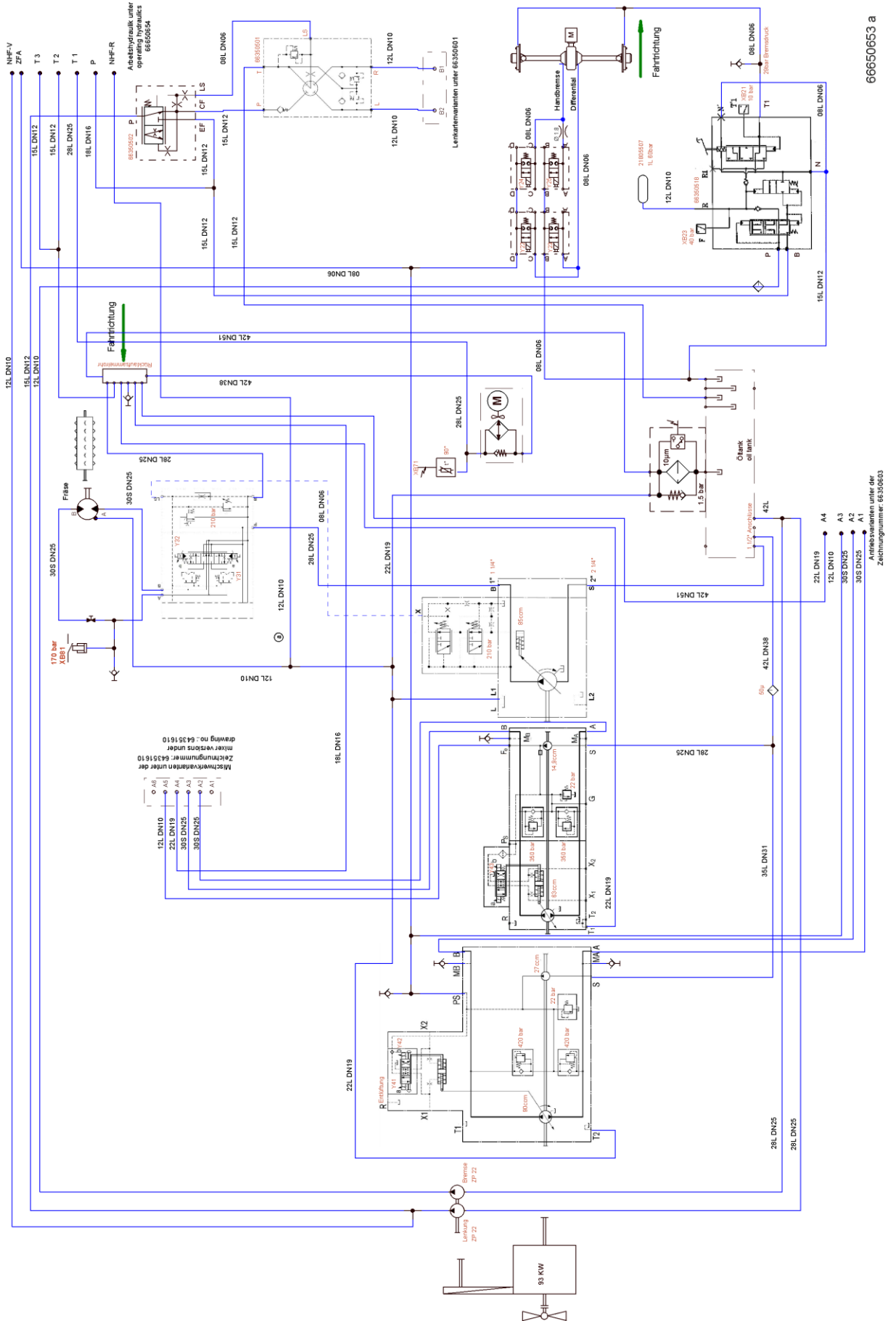

11.1.3 Traction drive hydraulics

Pumpenhydraulik siehe 66350602

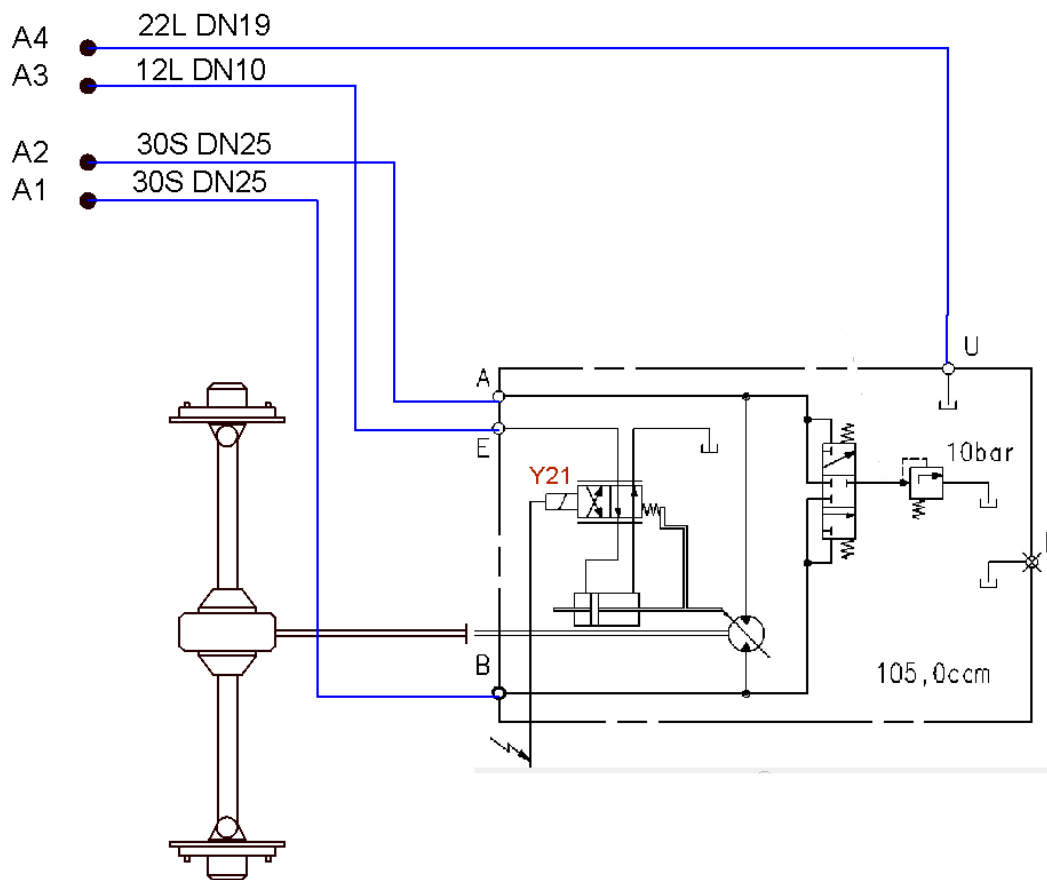

Fahrtrichtung

66350603 0

11.1.4 Mixing unit hydraulics

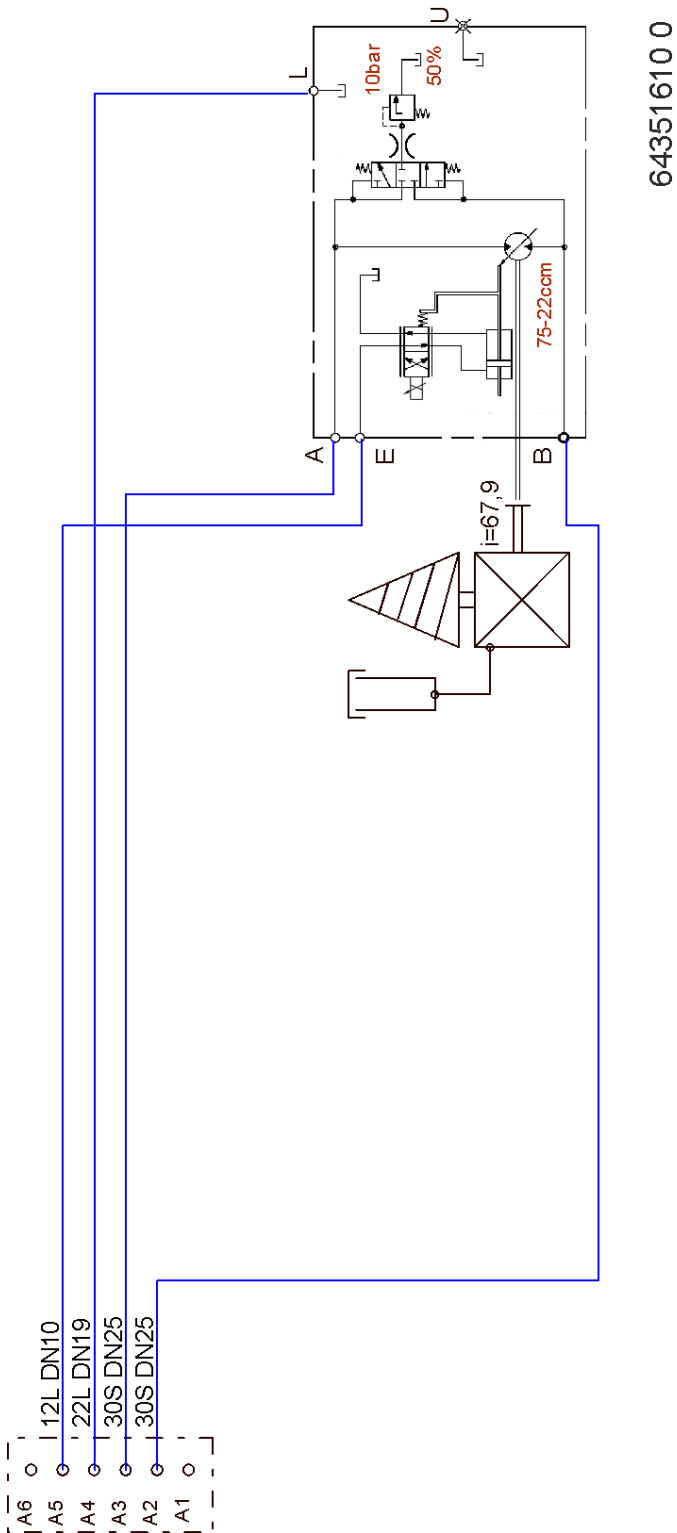

11.1.5 Steering hydraulics

Weiterführender Hydraulikschaltplan
unter Zeichnungsnummer: 66350602

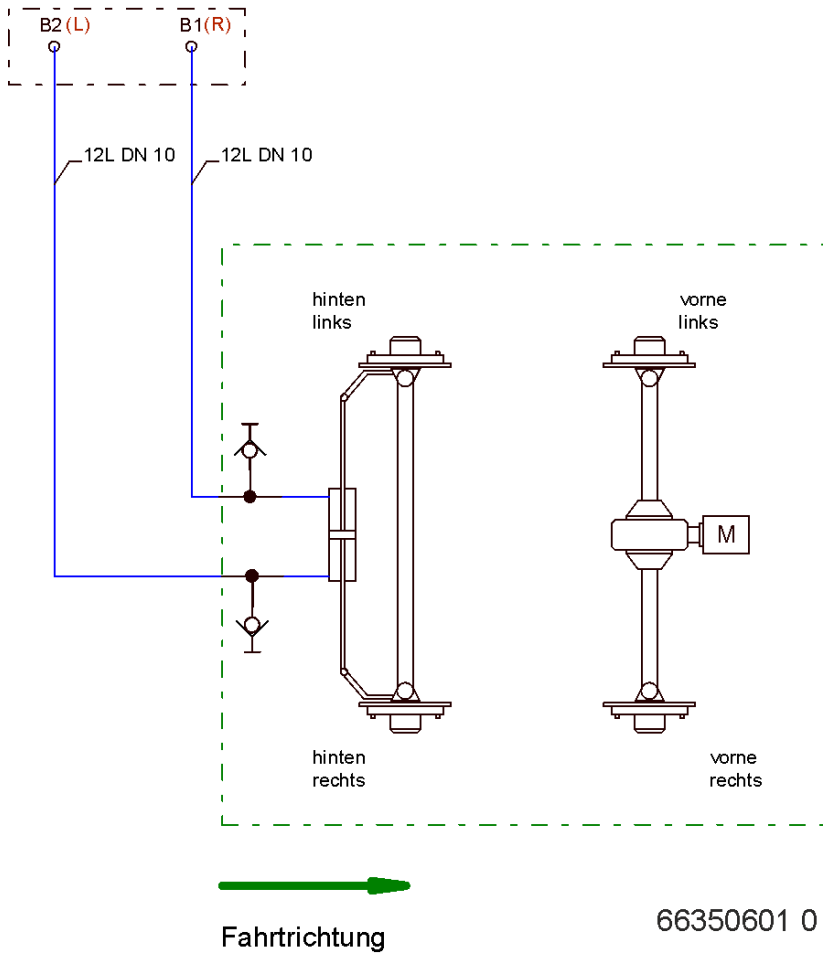

Index

A

Actuate full headlights.....	45
Actuate headlight flasher	45
Actuate horn	45
Actuate indicators	45
Adjust driver seat	43
Adjust mirrors.....	47
Adjust outside mirror.....	47
Adjust rear-view mirror.....	47
Adjust scraper bar.....	103
Adjust steering wheel position	44
Adjust supporting rollers	102
Alterations on the machine	25
Auxiliary materials.....	25
Axles	
Basic safety instructions.....	31

B

Basic safety instructions	
Axles.....	31
Brake system	31
Diesel engine	30
Electrical system	30
Hydraulic system.....	29
Safety and accident prevention instructions	26
Service and maintenance.....	32
Tyres	31
Use of machine	27
Battery main switch.....	16
Blockages	
Elimination.....	78
Brake system	
Basic safety instructions.....	31
Braking.....	68
Bunker silo	
Pick up silage	71

C

Chassis, hydraulic	
Adjust travelling height.....	111
Check/Top up central lubrication	113
Check/Top up coolant level	91
Check/Top up engine oil level	89
Check/Top up hydraulic oil level.....	91
Circuit diagrams.....	123
Clean ventilation filter	92

Clean/Replace air circulation filter	94
Clean/Replace fresh air filter.....	94
Cleaning	86
By means of pressure washer/steam blaster	87
Commissioning.....	41
Control console	
Switches/Key buttons	53
Conveyor drum stop.....	53
Correct use.....	22
Cutting unit	105
Check	105

D

Diagnosis menu	59
Diesel engine	
Basic safety instructions	30
Check/Top up oil level	89
Jumper battery.....	114
Winter operation	68
Disassembly.....	122
Discharge door	
Check/Adjust distance to mixing container	97
Disposal	122
Driver's cabin	14
Adjust driver seat.....	43
Get in and out.....	41
Heat	48
Open cabin door	41
Open door window.....	42
Ventilate.....	48

E

Electrical system	16
Basic safety instructions	30
Emergency lifting device of pick-up arm	118
Emergency manual operation in case of failure of electrical system	118
Extend/Retract counter-cutters	49

F

Feed hopper, hydraulic	
Fill in fodder additives.....	75
Fill in fodder additives	75
Filling.....	71
Mixing	76
Order	71
Fodder discharge	77

Fuses	16	Entry	82
G		Mixing unit hydraulics	128
Gear lubricant oil		O	
Check/Top up/Change	96	Open cabin door	41
General overview of machine	12	Open door window	42
Get in	41	Operating hydraulics	123
Get out	41	Operating media	83
H		Operation	53
Hazardous areas and dangerous spots	24	Joystick	56
Heat driver's cabin	48	Parameter/Diagnosis menu	58
Hydraulic chassis		Operator	
Adjust travelling height	111	Qualification	24
Hydraulic feed hopper		Overheating of hydraulic oil	53
Fill in fodder additives	75	Overview of machine	12
Hydraulic oil overheating	53	P	
Hydraulic oil tank		Parameter menu	64
Clean ventilation filter	92	Parameter/Diagnosis menu	58
Hydraulic system	19	Parking brake	
Basic safety instructions	29	Manual release	117
Check hose pipes	108	Pick up bales	74
Emergency manual operation	118	Pick up bulk materials	74
Open oil circulation system of traction drive	116	Pick up silage from the bunker silo	71
Stop-cocks	19	Pick-up arm	
I		Emergency lifting device	118
Instruction signs	38	Pick-up milling cutter	
Placing at machine	39	Turn over/Replace milling blades	104
J		Preheating devices	51
Joystick	56	Preservation of machine	86
Jumper battery	114	Product description	11
L		Product safety	24
Leakage points	30	Pump hydraulics	125
Liability	25	Q	
Lubrication	87	Qualification of operator	24
Lubrication plan	88	R	
M		Readjust Fast-Cut cutting knives	107
Machine overview	12	Refuelling	88
Maintenance	79	Relays	18
Adjust scraper bar	103	Remedy of malfunctions	114
Adjust supporting rollers	102	Overview	120
Wheel change	109	Remove/Fix radio remote control	48
Malfunctions and remedy	114	Replace Fast-Cut cutting knives/slide plates	108
Overview	120	Replace wiper blades	94
Manual throttle lever	66	Risk - Meaning	9
Mixing container		Road traffic regulations	67

S

Safety	
Basic safety instructions.....	26
Instruction signs	38
Risks in case of non-observance of safety instructions and warning signs	40
Secure pick-up arm against lowering	80
Warning and instructions signs	33
Warning signs	33
Safety and protective devices.....	25
Safety instructions	22
Activity-related safety instructions.....	9
Risks in case of non-observance	40
Screwed connections	
Tightening torques	110
Secure pick-up arm against lowering	80
Service and maintenance	
Basic safety instructions.....	32
Service and maintenance plan	84
Service of machine	79
Spare and wearing parts.....	25
Steering hydraulics	129
Stop of conveyor drum.....	53
Stop-cocks for hydraulic system	19
Structural alterations.....	25
Switch driving light on/off	44
Switch interior light on/off.....	46
Switch parking light on/off.....	44
Switch windscreen wiper on/off	
Windscreen	47
Switch windscreen wiper on/off	47
Switch work lights on/off	45
Switches/Key buttons of control console	53

T

Technical data	20
----------------------	----

Terminal	57
Diagnosis menu.....	59
Parameter menu.....	64
Tighten/Align side discharge conveyor	102
Tightening torques	110
Top up windscreen washing water.....	93
Tow machine.....	115
Towing.....	115
Traction drive	
Open hydraulic oil circulation system	116
Traction drive hydraulics	127
Travelling.....	68
Travelling mode.....	67
Turn over/Replace milling blades.....	104
Type plate	20
Tyres	
Basic safety instructions	31

U

Unroll/Roll up sun blind	46
Use of machine	71
Basic safety instructions	27

V

Ventilate driver's cabin	48
--------------------------------	----

W

Warning and instructions signs	33
Warning lamp	
Conveyor drum stop	53
Hydraulic oil overheating	53
Warning signs	33
Placing at machine	39
Risks in case of non-observance	40
Warranty.....	25
Wheel change	109

Verfasser	Freigeber	Freigabedatum	Sprache
AxF	AxF	05.10.2016	EN

Zuordnung	
PG	Futtermischwagen SF
WG	Sherpa
Modell	1201, 1401